



# SEAGULL 40

LOW WING TRAINER

Hand-made Almost Ready to Fly R/C Model Aircraft

MS:10

## ASSEMBLY MANUAL

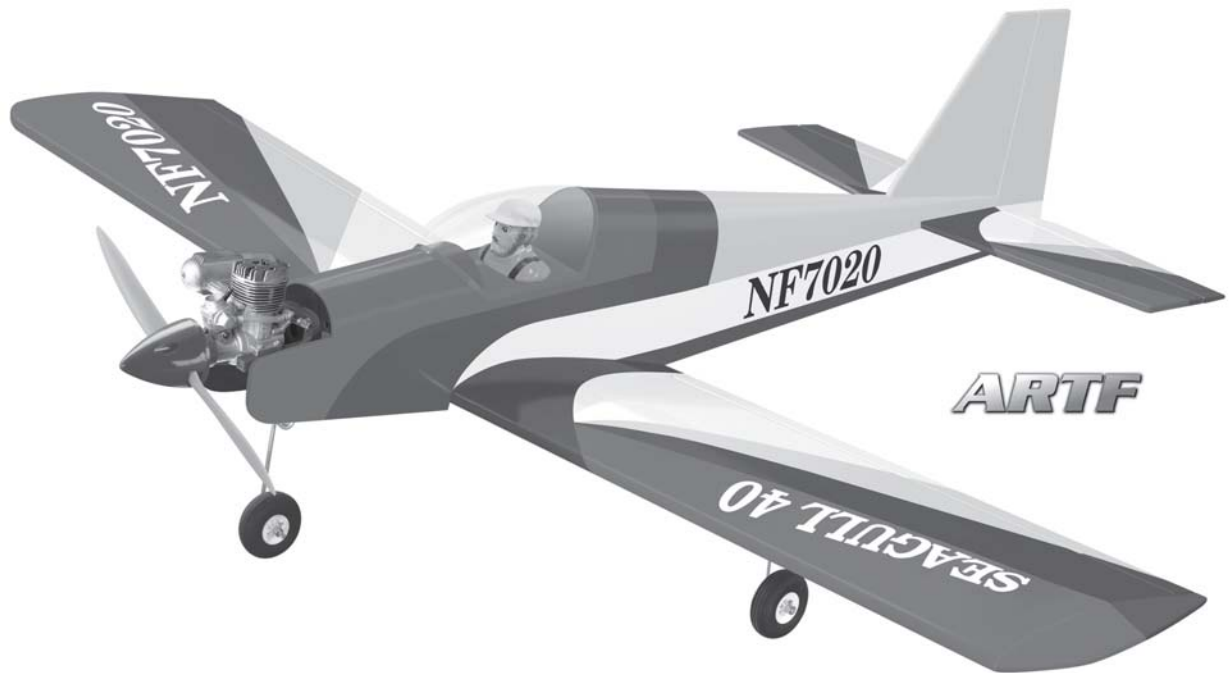

## **FACTORY BUILT MODEL**

### Specifications

Wing span \_\_\_\_\_ 60in, 153cm.  
Wing area \_\_\_\_\_ 620sq.in, 40dm<sup>2</sup>.  
Length \_\_\_\_\_ 45in, 113.7cm.  
Approximate flying weight \_\_\_\_\_ 5.5-6.2lbs, 2.5-2.8kg.  
Recommended engine size \_\_\_\_ .40-.46 cu. in 2-stroke.  
\_\_\_\_ .52 cu. in 4-stroke.  
Recommended R/C \_\_\_\_\_ 4 channel minimum.  
Flying skill level \_\_\_\_\_ Low wing Trainer.

### Additional items required.

Engine.  
4 Channel or greater Radio Control system.  
Glues.  
Tools.  
Starting Equipment.

### **Kit features.**

- Ready-made-minimal assembly & finishing required.
- Ready-covered-including decals, trim & covering.
- Factory-installed pushrod.
- Photo-illustrated step-by-step Assembly Manual.



**FACTORY BUILT MODEL**

Made in Vietnam.

**INTRODUCTION.**

Thank you for choosing the **SEAGULL 40** LOW WING TRAINER ARTF by SEAGULL MODELS. The **SEAGULL 40** was designed with the intermediate/advanced sport flyer in mind. It is a low-wing aeroplane which is easy to fly and quick to assemble. The airframe is conventionally built using balsa, plywood to make it stronger than the average ARTF, yet the design allows the aeroplane to be kept light. You will find that most of the work has been done for you already. Flying the **SEAGULL 40** is simply a joy.

This instruction manual is designed to help you build a great flying aeroplane. Please read this manual thoroughly before starting assembly of your **SEAGULL 40**. Use the parts listing below to identify all parts.

**WARNING.**

***Please be aware that this aeroplane is not a toy and if assembled or used incorrectly it is capable of causing injury to people or property. WHEN YOU FLY THIS AEROPLANE YOU ASSUME ALL RISK & RESPONSIBILITY.***

If you are inexperienced with basic R/C flight we strongly recommend you contact your R/C supplier and join your local R/C Model Flying Club. R/C Model Flying Clubs offer a variety of training procedures designed to help the new pilot on his way to successful R/C flight. They will also be able to advise on any insurance and safety regulations that may apply.

**NOTE:** To avoid scratching your new aeroplane we suggest that you cover your workbench with an old towel. Keep a couple of jars or bowls handy to hold the small parts after you open the bags.

Please trial fit all parts. Make sure you have the correct parts and that they fit and are aligned properly before gluing! This will ensure proper assembly as the **SEAGULL 40** is made from natural materials and minor adjustments may have to be made.

The paint and plastic parts used in this kit are fuel proof. However, they are not tolerant of many harsh chemicals including the following: paint thinner, cyano-acrylate glue accelerator, cyanoacrylate glue de-bonder and acetone. Do not let these chemicals come in contact with the colours on the covering and the plastic parts.



## HINGING THE AILERONS.

**Note:** *The control surfaces, including the ailerons, elevators, and rudder, are prehinged with hinges installed, but the hinges are not glued in place. It is imperative that you properly adhere the hinges in place per the steps that follow using a high-quality thin C/A glue.*

- 1) Carefully remove the aileron from one of the wing panels. Note the position of the hinges.

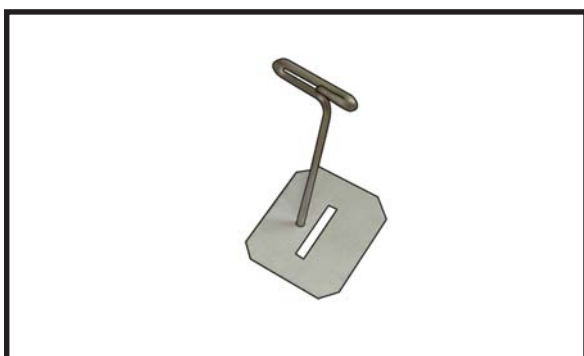

- 2) Remove each hinge from the wing panel and aileron and place a T-pin in the center of each hinge. Slide each hinge into the wing panel until the T-pin is snug against the wing panel. This will help ensure an equal amount of hinge is on either side of the hinge line when the aileron is mounted to the aileron.

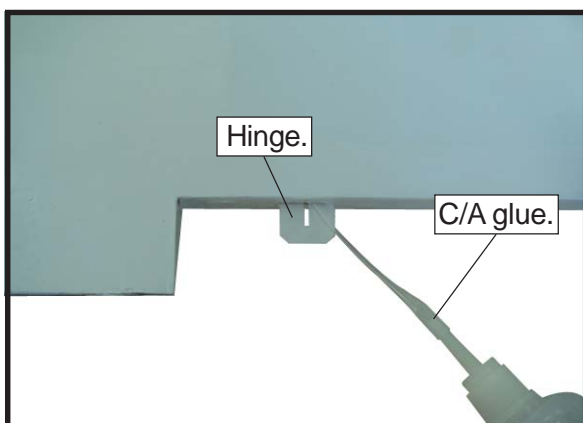

- 3) Slide the wing panel on the aileron until there is only a slight gap. The hinge is now centered on the wing panel and aileron. Remove the T-pins and snug the aileron against the wing panel. A gap of 1/64" or less should be maintained between the wing panel and aileron.



- 4) Deflect the aileron and completely saturate each hinge with thin C/A glue. The ailerons front surface should lightly contact the wing during this procedure. Ideally, when the hinges are glued in place, a 1/64" gap or less will be maintained throughout the length of the aileron to the wing panel hinge line.

**Note:** *The hinge is constructed of a special material that allows the C/A to wick or penetrate and distribute throughout the hinge, securely bonding it to the wood structure of the wing panel and aileron.*

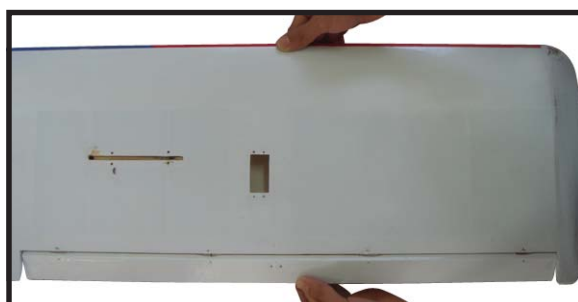
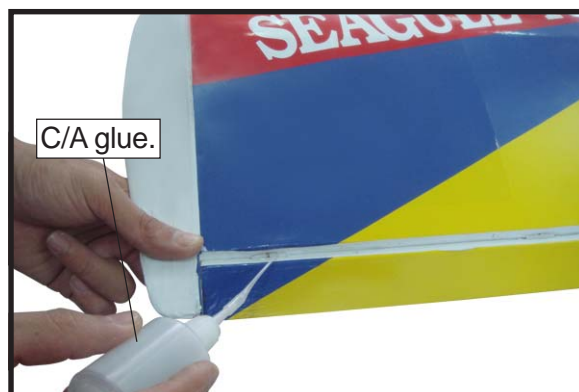

□ 5) Turn the wing panel over and deflect the aileron in the opposite direction from the opposite side. Apply thin C/A glue to each hinge, making sure that the C/A penetrates into both the aileron and wing panel.

□ 6) Using C/A remover/debonder and a paper towel, remove any excess C/A glue that may have accumulated on the wing or in the aileron hinge area.

□ 7) Repeat this process with the other wing panel, securely hinging the aileron in place.

□ 8) After both ailerons are securely hinged, firmly grasp the wing panel and aileron to make sure the hinges are securely glued and cannot be pulled out. Do this by carefully applying medium pressure, trying to separate the aileron from the wing panel. Use caution not to crush the wing structure.



**Note:** *Work the aileron up and down several times to “work in” the hinges and check for proper movement.*

### HINGING THE ELEVATOR.

Glue the elevator hinges in place using the same techniques used to hinge the ailerons.

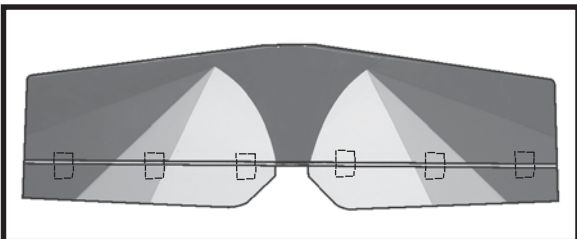

### HINGING THE RUDDER.

Glue the rudder hinges in place using the same techniques used to hinge the ailerons.

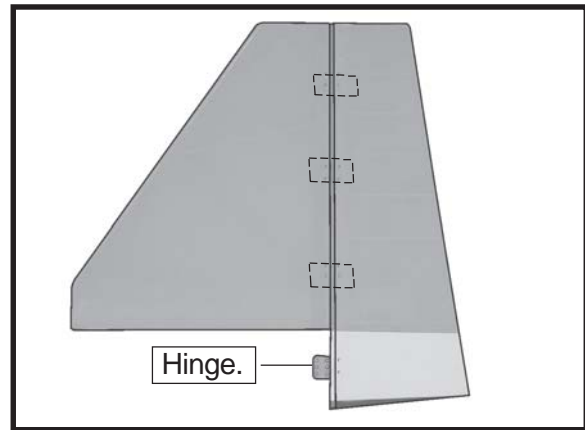

### WING ASSEMBLY.

**NOTE:** *We highly recommend using 30 minute epoxy as it is stronger and provides more working time, allowing the builder to properly align the parts. Using fast cure epoxy when joining the wing halves could result in the glue drying before the wing halves are aligned properly which may result in failure of the wing centre section during flight.*

□ 1) Locate the plywood wing dihedral brace. Using a ruler, locate its centre and draw a vertical line.

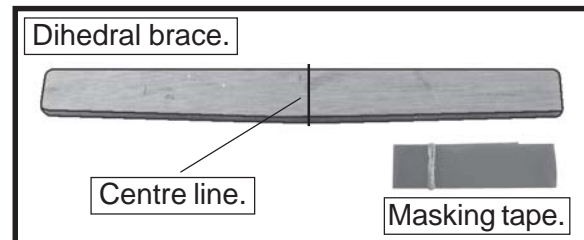

□ 2) Test fit the dihedral brace into each wing half. The brace should slide in easily up to the centreline that you drew. If not, use 220 grit sandpaper with a sanding block and sand down the edges and ends of the brace until it fits properly.

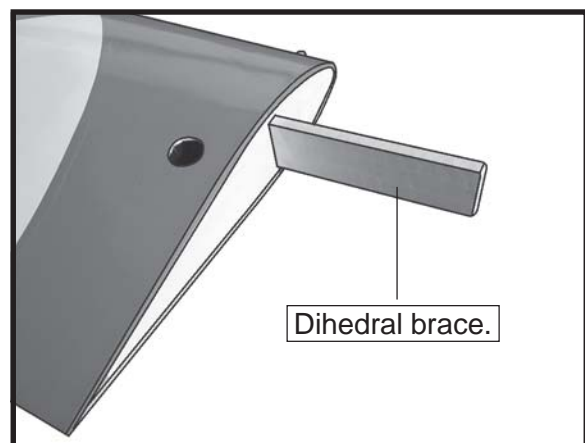

- 3) Remove the brace when satisfied with its fit in each wing half. Coat both sides of one half of the dihedral brace with 30 minute epoxy. Next, pour some epoxy into the dihedral box in one wing panel. Make sure you cover the top and bottom as well as the sides of the dihedral brace. Use enough epoxy to fill any gaps.

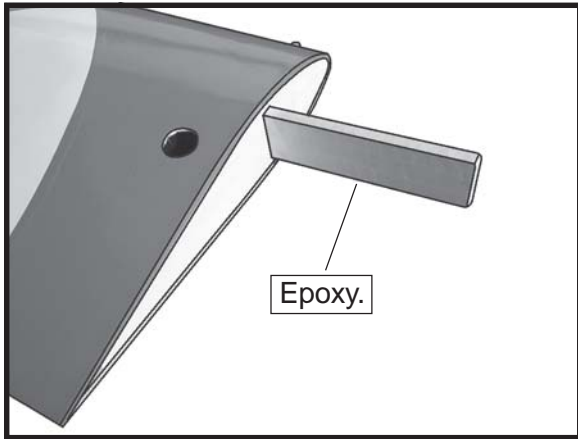

Carefully slide the two wing halves together and firmly press them together, allowing the excess epoxy to run out. There should not be any gap in the wing halves. Use rubbing alcohol and a paper towel to clean up any excess epoxy.

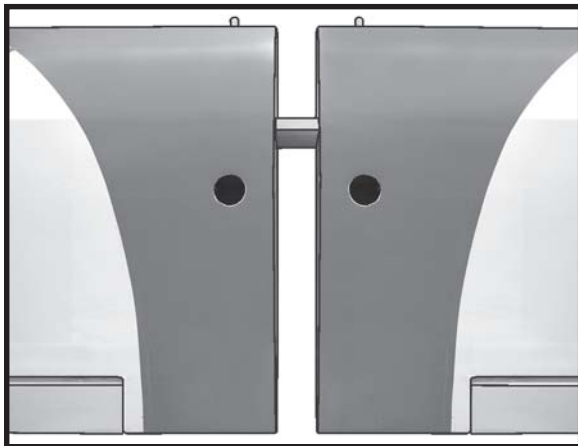

Apply masking tape at the wing join to hold the wing halves together securely.

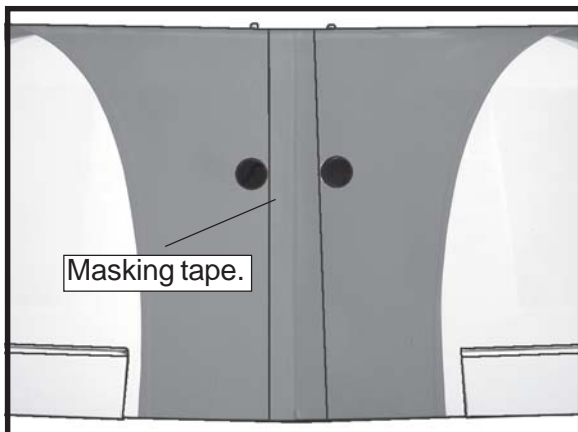

- 4) Peel off the backing from the self adhesive covering strip. Apply the strip to the centre section of the wing starting from the bottom trailing edge. Wrap the strip all the way around the wing until it meets the trailing edge again. Trim off any excess strip.

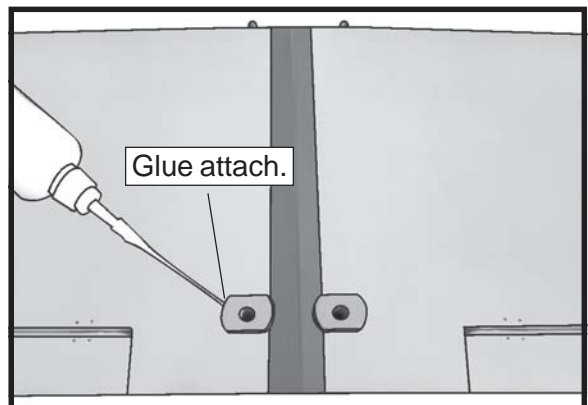
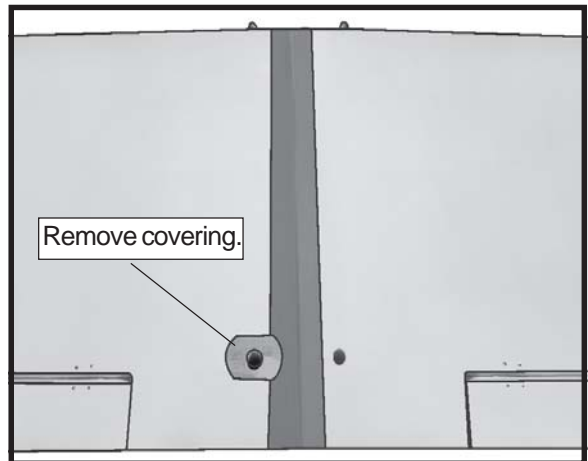
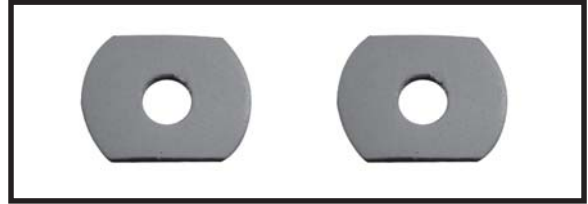

### INSTALLING THE AILERON SERVOS.



- 1) Install the rubber grommets and brass collets onto the aileron servo. Test fit the servo into the aileron servo mount.

**!** *Because the size of servos differ, you may need to adjust the size of the precut opening in the mount. The notch in the sides of the mount allow the servo lead to pass through.*

- 2) Using a small weight (Weighted fuel pick-up works well) and thread, feed the string through the wing as indicated.

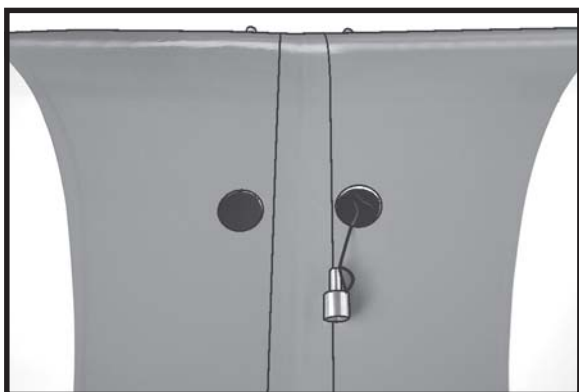
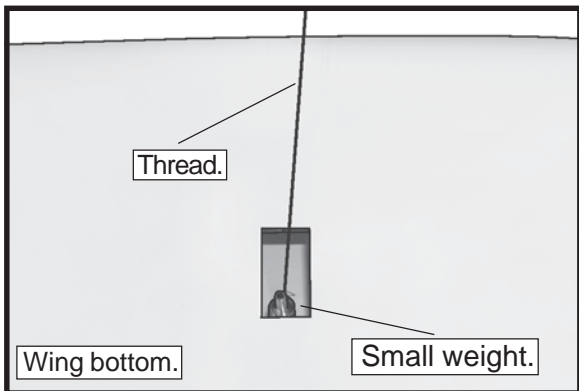
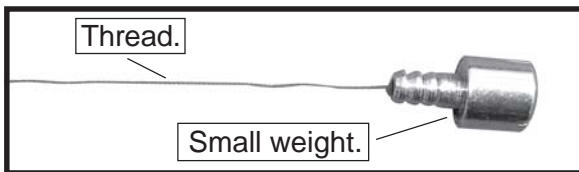

- 3) Attach servo lead to the aileron servo. Attach the string to the servo lead and carefully thread it through the wing. Once you have thread the lead through the wing, remove the string so it can use for the other servo lead.

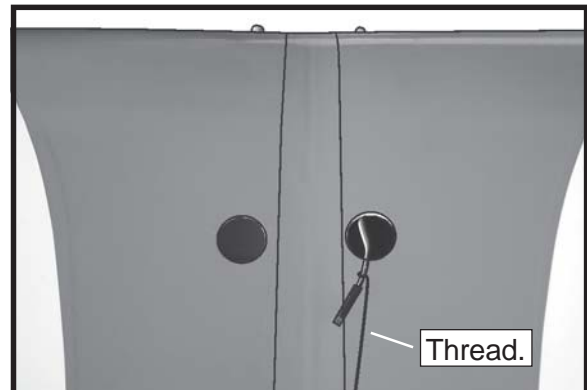
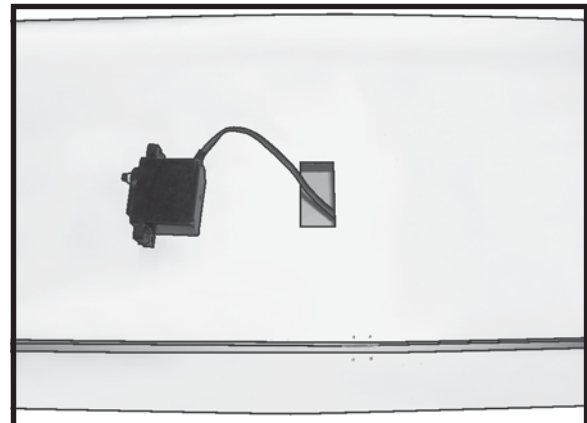
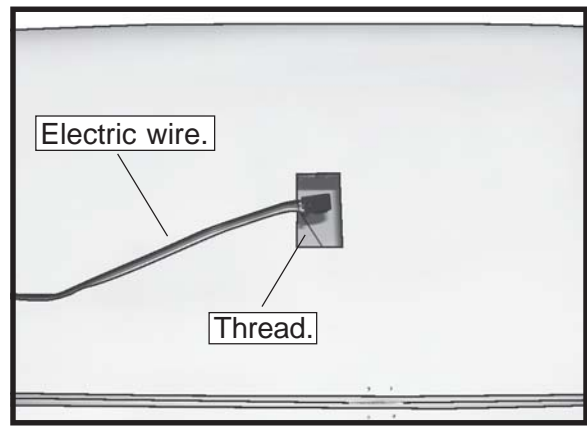

- 4) Tape the servo lead to the wing to prevent it from falling back into the wing.

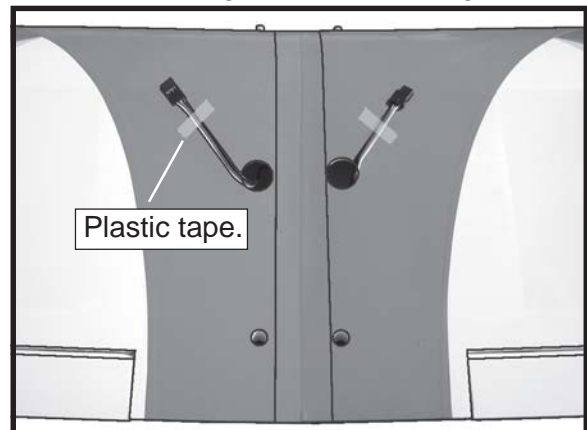

- 5) Reinstall the servo into the servo mount and secure the servo in place using the wood screws provided with you radio system.

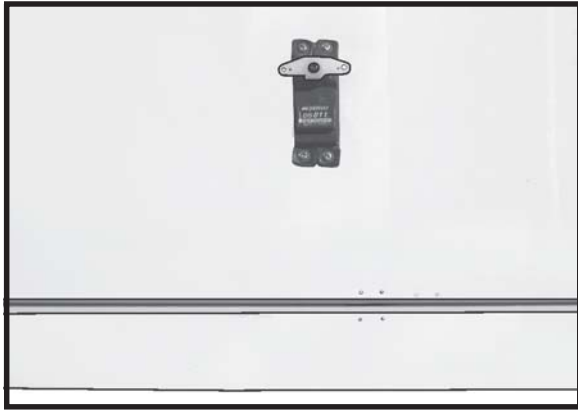

Repeat the procedure for the other wing half.

### AILERON LINKAGE.

- 1) Using a ruler & pen to draw a straight line as below picture.

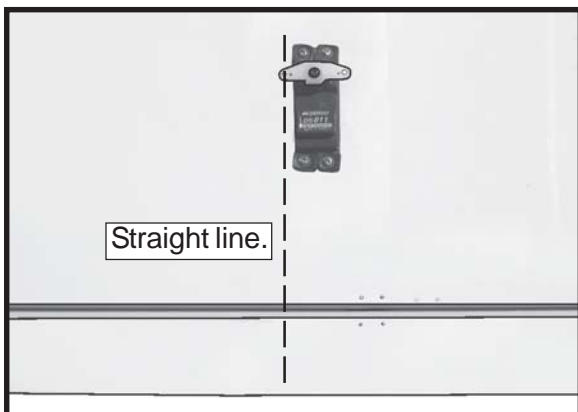
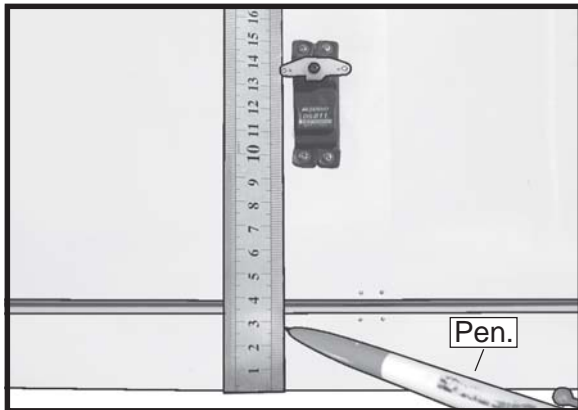

- 2) Locate the two nylon control horns, two nylon control horn backplates and four machine screws.
- 3) Position the aileron horn on the bottom side of aileron. The clevis attachment holes should be positioned over the hinge line.

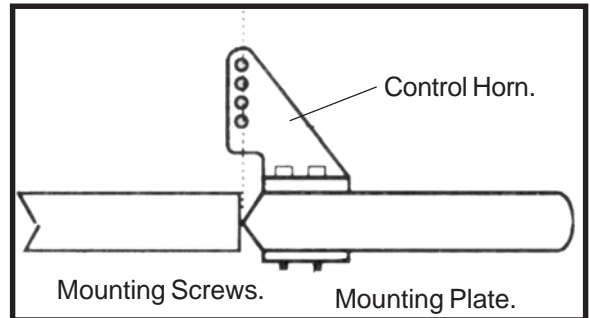
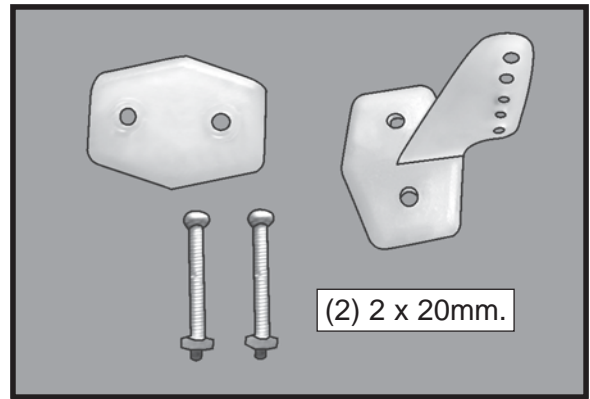

- 4) Using a 1mm drill bit and the control horns as a guide, drill the mounting holes through the aileron halves.

- 5) Mount the control horns by inserting the screws through the control horn bases and aileron halves, then into the mounting backplates. Do not overtighten the screws or the backplates may crush the wood.

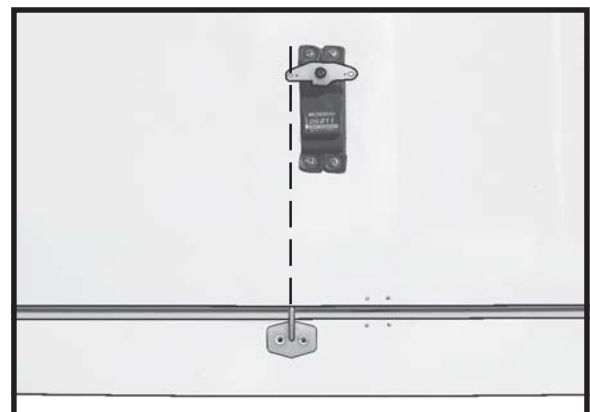

- 6) Thread one nylon adjustable control horn onto each aileron control rod. Thread the horns on until they are flush with the ends of the control rods.
- 7) With the aileron servo centered and the aileron even with the trailing edge of the wing attach the clevis to the control horn. Mark the control wire where it crosses the servo arm hole.

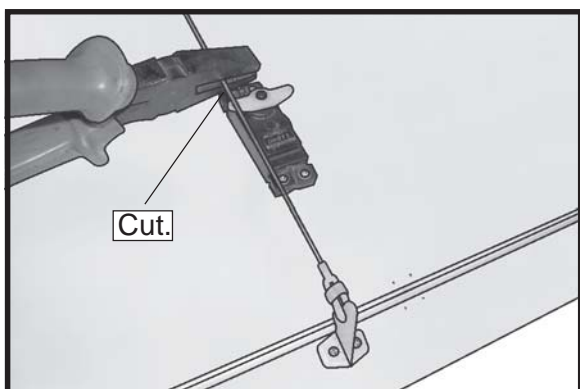
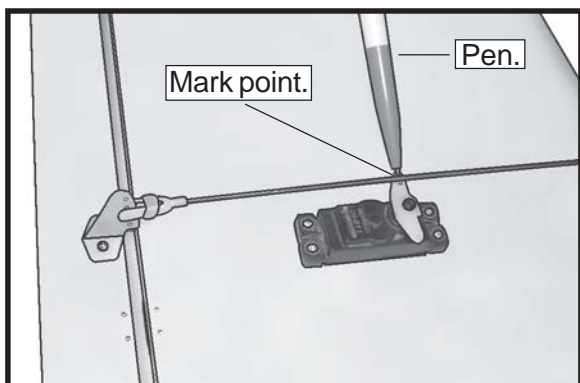

- 8) Make a 90-degree bend at the mark and cut off the excess wire leaving 10mm past the bend.

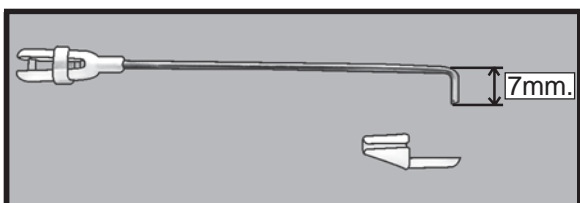

- 9) Connect the linkage as shown and secure the control wire with a wire keeper.

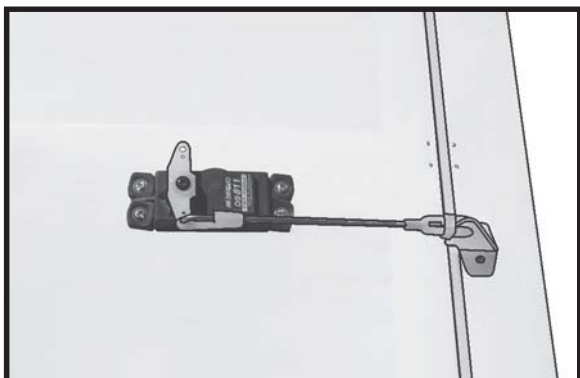

Repeat the procedure for the other aileron servo.

**INSTALLING THE MAIN GEAR WIRES.**

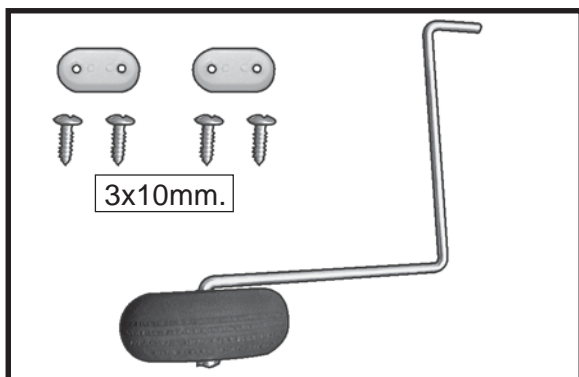

- 1) Using a modeling knife, remove the covering from over the two main gear mounting slots located in the bottom of the wing.

- 2) Insert the 90° bend of one main gear wire into the predrilled hole in one mounting slot.

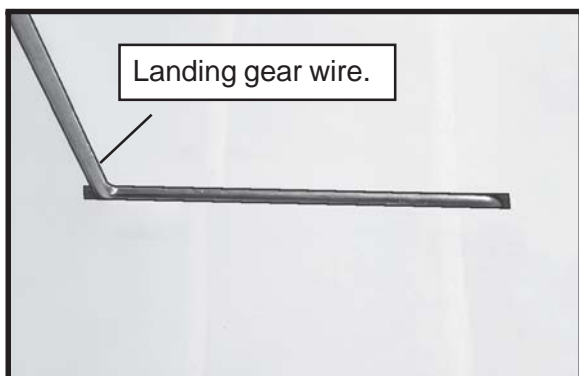
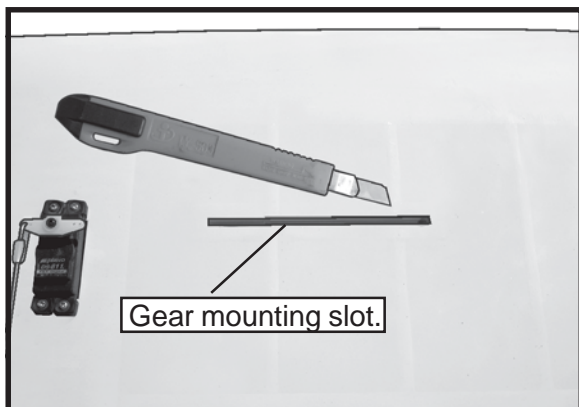





- 4) Carefully heat the vent tube using a heat gun or lighter to permanently set the angle of the tube.

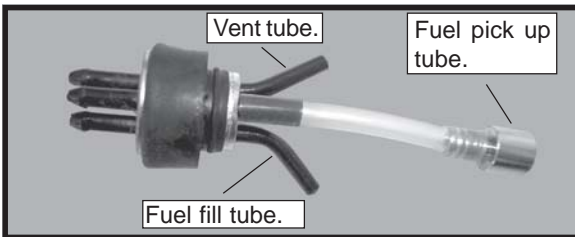

When the stopper assembly is installed in the tank, the top of the vent tube should rest just below the top surface of the tank. It should not touch the top of the tank.

- 5) Test fit the stopper assembly into the tank. It may be necessary to remove some of the flashing around the tank opening using a modeling knife. If flashing is present, make sure none falls into the tank.

- 6) With the stopper assembly in place, the weighted pick up should rest about 3/8" away from the rear of the tank and move freely inside the tank. The top of the vent tube should rest just below the top of the tank. It should not touch the top of the tank.

- 7) When satisfied with the alignment of the stopper assembly tighten the 3mm x 20mm machine screw until the rubber stopper expands and seals the tank opening. Do not overtighten the assembly as this could cause the tank to split.

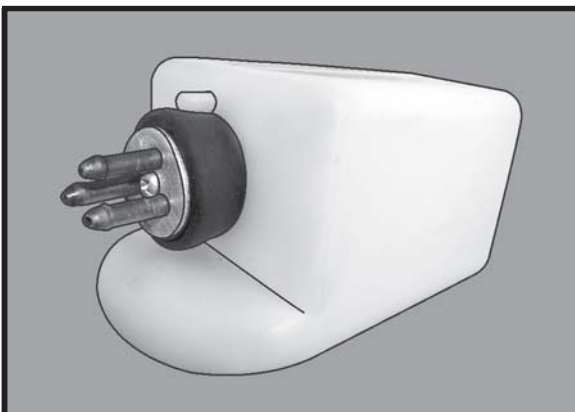

Using a modeling knife, cut one length of fuel line 20" long. Connect one line to the vent tube and one line to the fuel pick up tube on the stopper. See picture bellow.

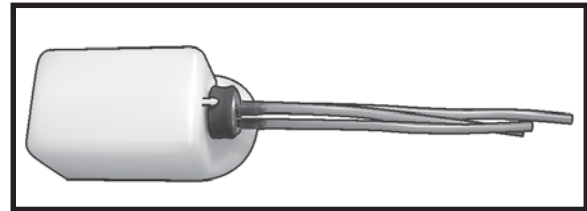

**!** *Blow through the tubes to make sure the lines have not become kinked during installation.*

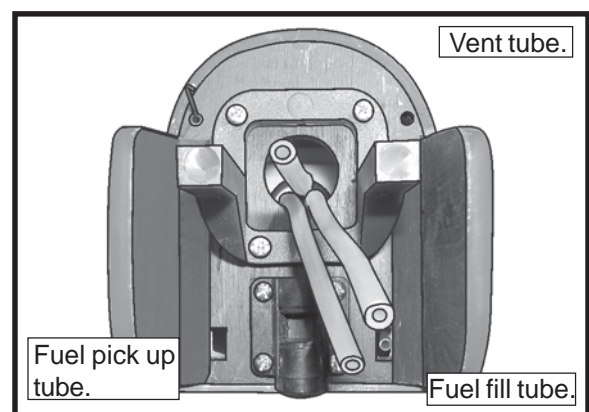
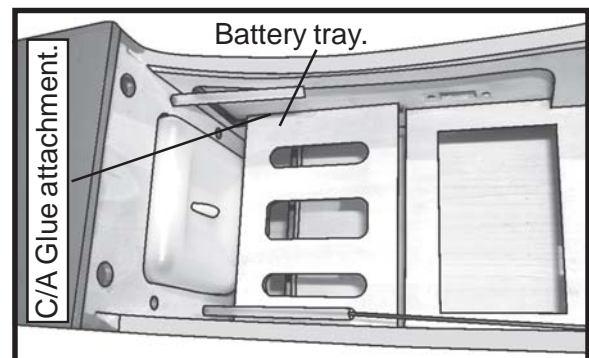
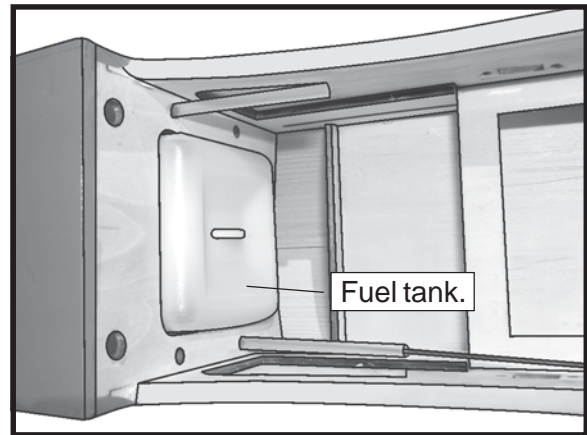

### MOUNTING THE ENGINE.

□ 1) Install the pushrod housing through the predrilled hole in the firewall and into the servo compartment. The pushrod housing should protrude 1/4" out past the front of the firewall.

Make a Z-Bend 1/4" from one end of the plain wire pushrod.

□ 2) Place your engine onto the engine mount. Adjust the engine is centered of the edges of the engine case.

□ 3) When you are satisfied with the alignment, mark the locations of the engine mounting.

□ 4) Remove the engine. Using an drill bit, drill the mounting holes through the engine mount at the four locations marked.

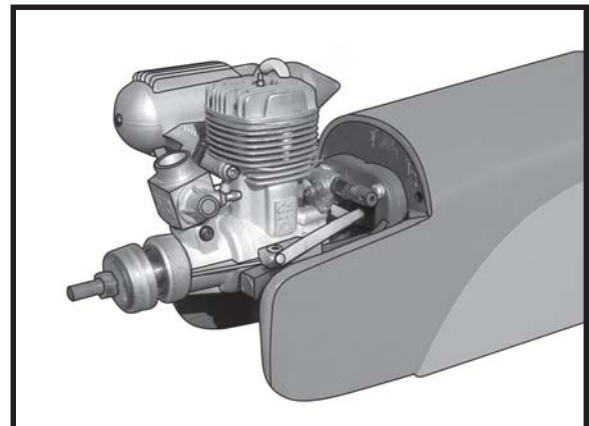
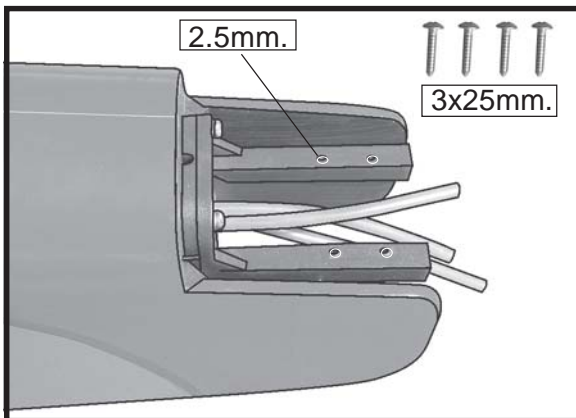
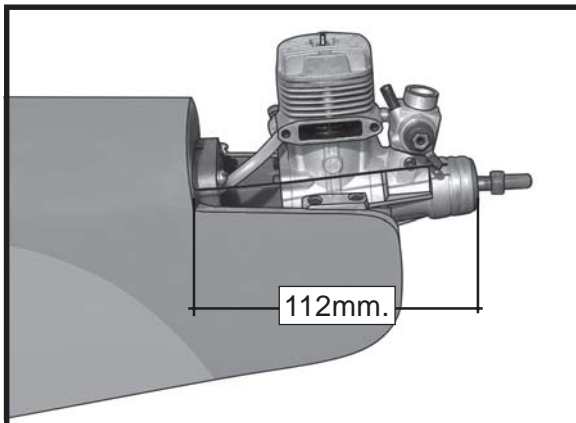
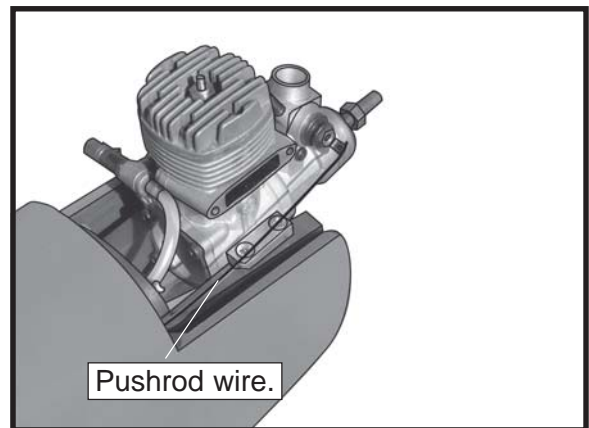
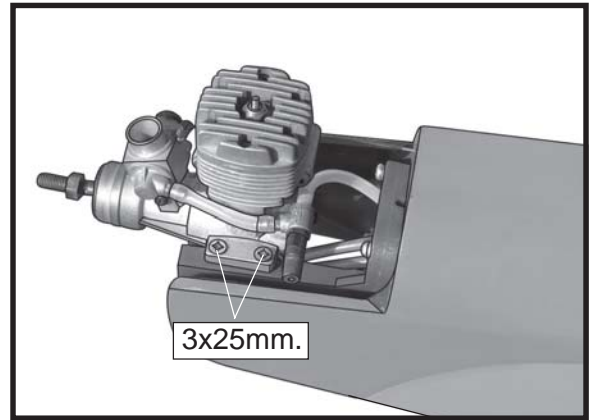

### NOSE GEAR INSTALLATION.

□ 5) Bolt the engine to the engine mount using the four machine screws. Double check that all the screws are tight before proceeding.

□ 6) Attach the Z-Bend in the pushrod wire to the throttle arm on the carburetor. You will need to remove the throttle arm from the carburetor to be able to attach the Z-bend. When complete, re-attach the throttle arm to the carburetor.



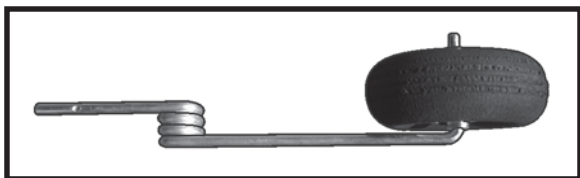

Installing steering arm as below.



Adjust the nose gear steering arm until the arm is parallel with the fire wall.

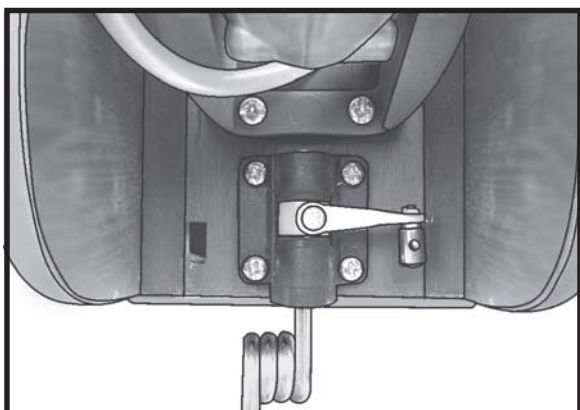

Install the pushrod wire as shown.

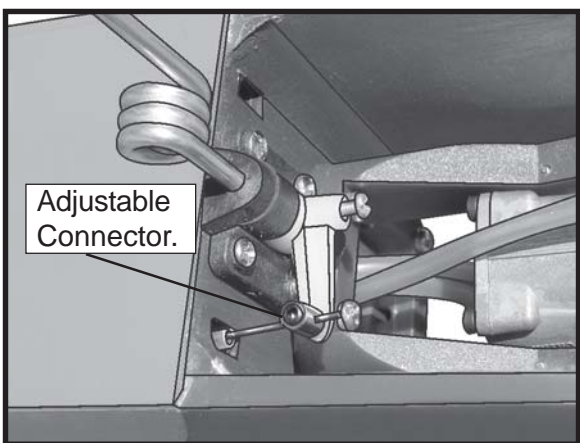

**INSTALLING THE SPINNER.**

Install the spinner backplate, propeller and spinner cone. The spinner cone is held in place using two 3 x 15mm wood screws.

**!** *The propeller should not touch any part of the spinner cone. If it does, use a sharp modeling knife and carefully trim away the spinner cone where the propeller comes in contact with it.*

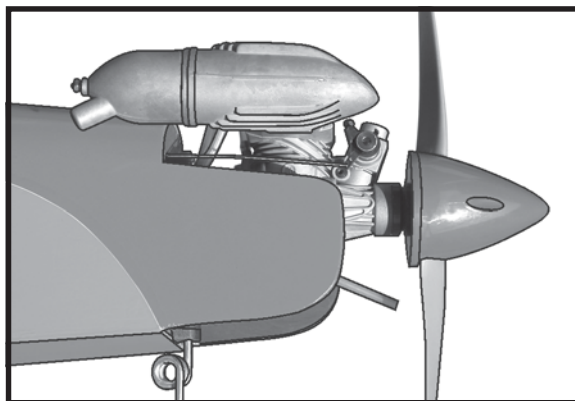
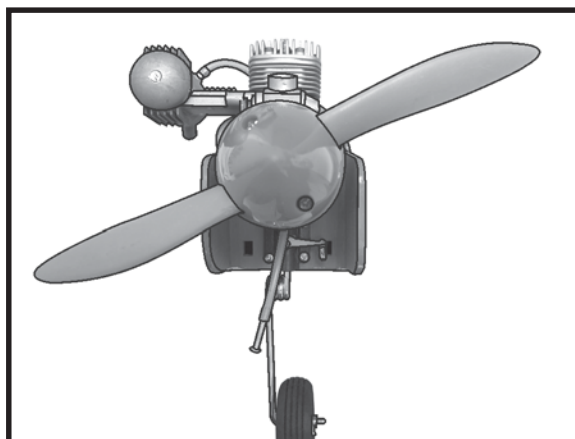
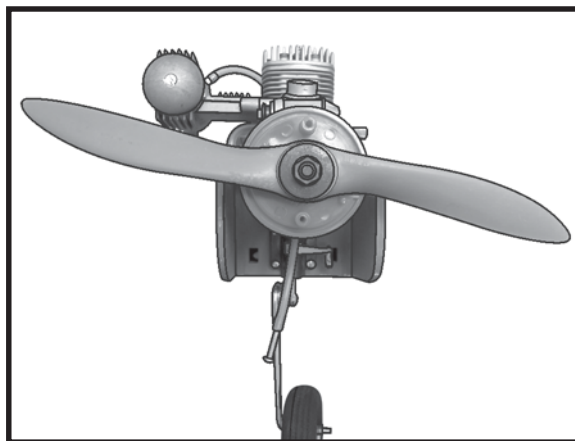

**INSTALLING THE SWITCH.**

□ 1) Install the switch into the precut hole in the fuselage side. Use the two screws provided with the switch to secure it in place.



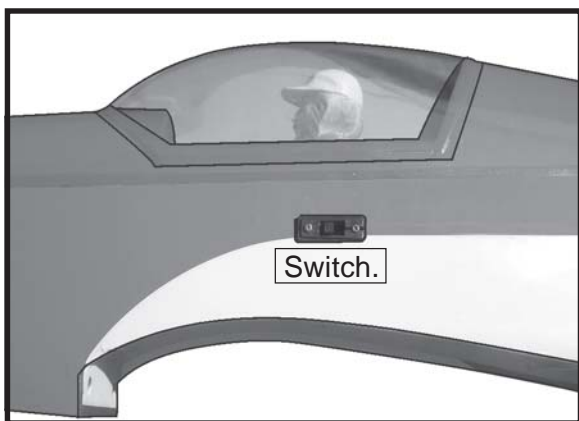

**INSTALLING THE FUSELAGE SERVOS.**



□ 1) Install the rubber grommets and brass collets onto the elevator, rudder and throttle servos. Test fit the servos into the preinstalled servo tray. Because the size of servos differ, you may need to adjust the size of the precut openings in the tray.

Secure the servos with the screws provided from your radio system.

□ 2) Position the servos into the servo tray with the output shafts orientated as shown below. Drill 1/16" pilot holes through the tray for each of the mounting screws.

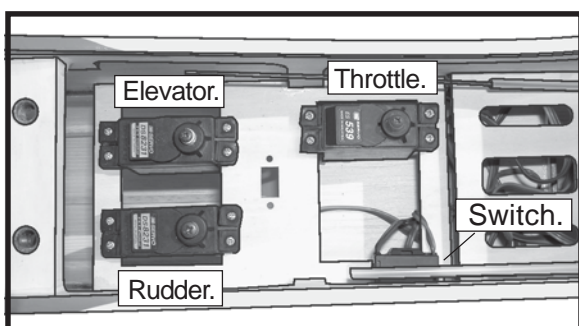

**HORIZONTAL STABILIZER.**

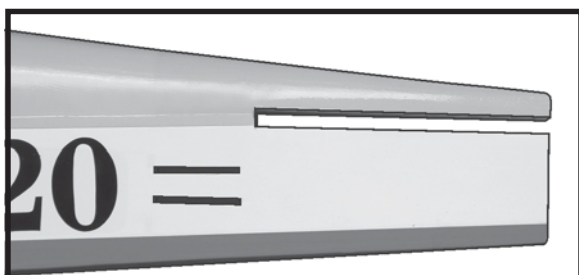

□ 1) Using a ruler and a pen, locate the centerline of the horizontal stabilizer, at the trailing edge, and place a mark. Use a triangle and extend this mark, from back to front, across the top of the stabilizer. Also extend this mark down the back of the trailing edge of the stabilizer.

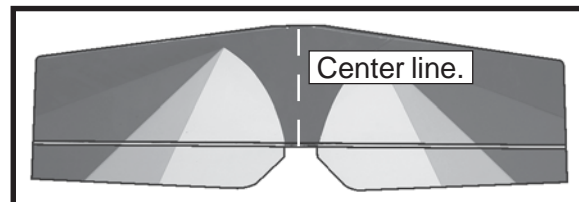

□ 2) Using a modeling knife, carefully remove the covering from over the vertical stabilizer mounting slot in the top of the fuselage.

□ 3) Slide the stabilizer into place in the pre-cut slot in the rear of the fuselage. The stabilizer should be pushed firmly against the front of the slot.

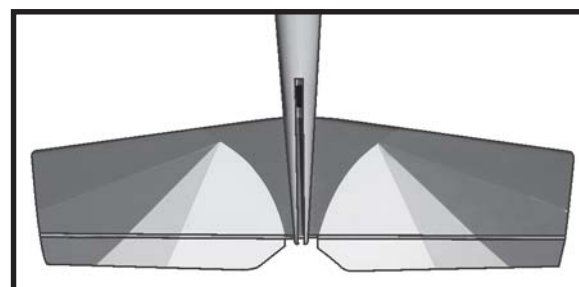

□ 4) With the stabilizer held firmly in place, use a pen and draw lines onto the stabilizer where it and the fuselage sides meet. Do this on both the right and left sides and top and bottom of the stabilizer.

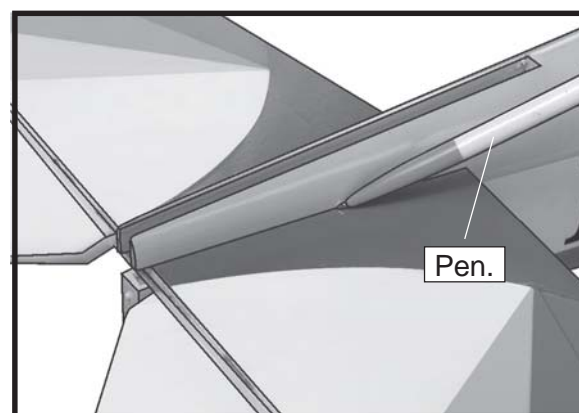

□ 5) Remove the stabilizer. Using the lines you just drew as a guide, carefully remove the covering from between them using a modeling knife.

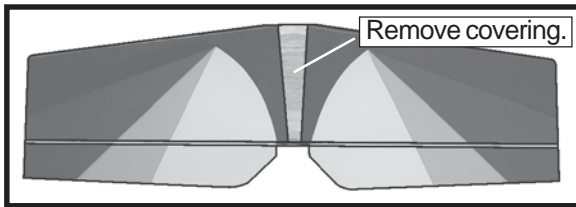

**!** *When cutting through the covering to remove it, cut with only enough pressure to only cut through the covering itself. Cutting into the balsa structure may weaken it.*

□ 6) Using a modeling knife, carefully remove the covering that overlaps the stabilizer mounting platform sides in the fuselage. Remove the covering from both the top and the bottom of the platform sides.

□ 7) When you are sure that everything is aligned correctly, mix up a generous amount of 30 Minute Epoxy. Apply a thin layer to the top and bottom of the stabilizer mounting area and to the stabilizer mounting platform sides in the fuselage. Slide the stabilizer in place and realign. Double check all of your measurements once more before the epoxy cures. Hold the stabilizer in place with T-pins or masking tape and remove any excess epoxy using a paper towel and rubbing alcohol.

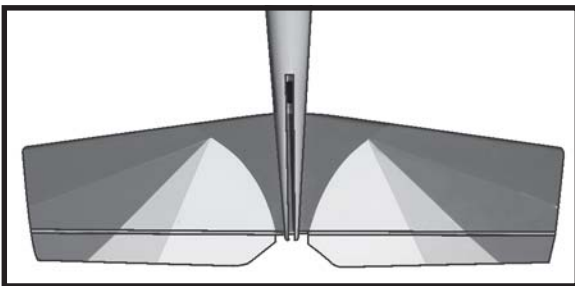

□ 8) After the epoxy has fully cured, remove the masking tape or T-pins used to hold the stabilizer in place. Carefully inspect the glue joints. Use more epoxy to fill in any gaps that may exist that were not filled previously and clean up the excess using a paper towel and rubbing alcohol.

## VERTICAL STABILIZER INSTALLATION.

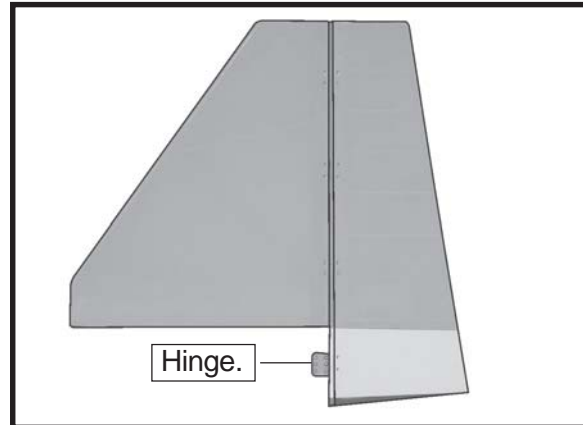

□ 1) Using a modeling knife, remove the covering from over the precut hinge slot cut into the lower rear portion of the fuselage. This slot accepts the lower rudder hinge.

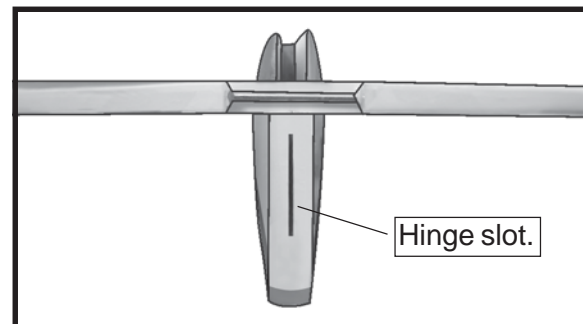

□ 2) Slide the vertical stabilizer into the slot in the top of the fuselage. The rear edge of the stabilizer should be flush with the rear edge of the fuselage and the lower rudder hinge should engage the precut hinge slot in the lower fuselage. The bottom edge of the stabilizer should also be firmly pushed against the top of the horizontal stabilizer.

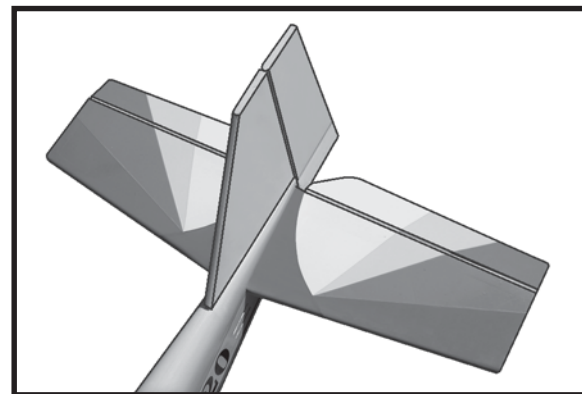

□ 3) While holding the vertical stabilizer firmly in place, use a pen and draw a line on each side of the vertical stabilizer where it meets the top of the fuselage.

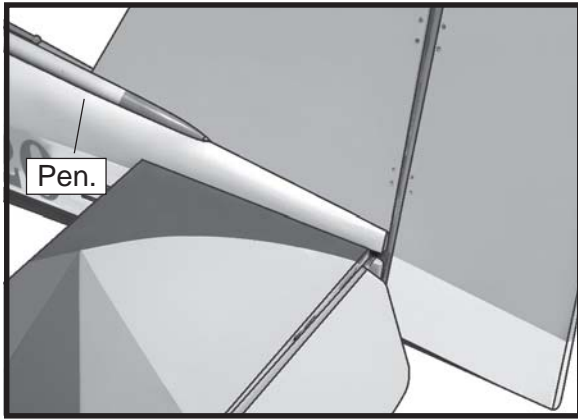

□ 4) Remove the stabilizer. Using a modeling knife, remove the covering from below the lines you drew.

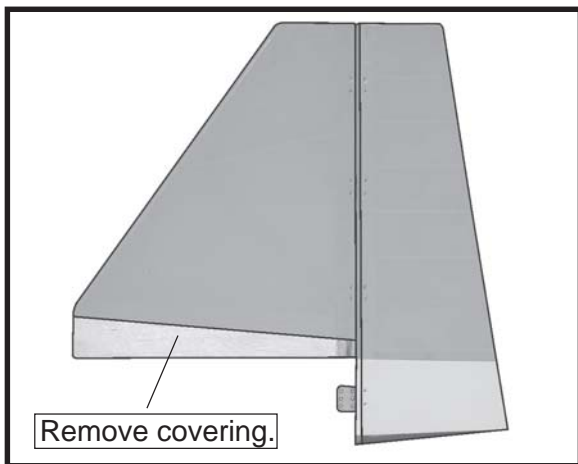

**!** *When cutting through the covering to remove it, cut with only enough pressure to only cut through the covering itself. Cutting into the balsa structure may weaken it.*

□ 5) Slide the vertical stabilizer back in place. Using a triangle, check to ensure that the vertical stabilizer is aligned 90° to the horizontal stabilizer.

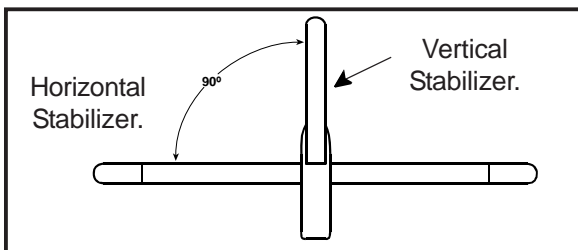

□ 6) When you are sure that everything is aligned correctly, mix up a generous amount of 30 Minute Epoxy. Apply a thin layer to the mounting slot in the top of the fuselage and to the sides and bottom of the vertical stabilizer mounting area. Apply epoxy to the bottom and top edges of the filler block and to the lower hinge also. Set the stabilizer in place and realign. Double check all of your measurements once more before the epoxy cures. Hold the stabilizer in place with T-pins or masking tape and remove any excess epoxy using a paper towel and rubbing alcohol. Allow the epoxy to fully cure before proceeding.

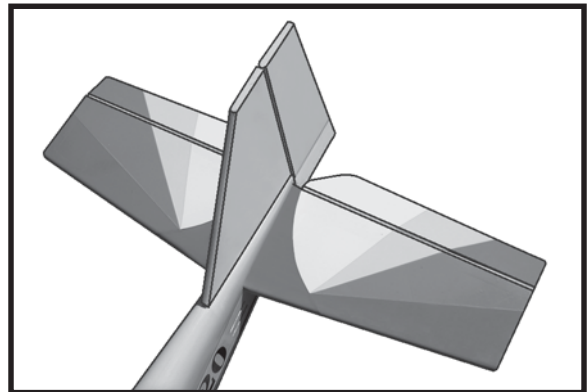

### CONTROL HORN INSTALLATION.

□ 1) Locate the nylon control horns- nylon control horn backplates and machine screws.

□ 2) The position of elevator control horn on the left side of elevator. The clevis attachment holes should be positioned over the hinge line.

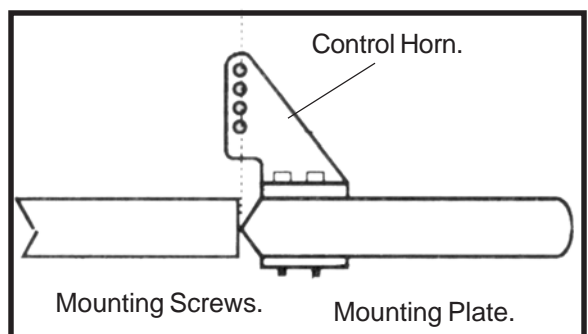
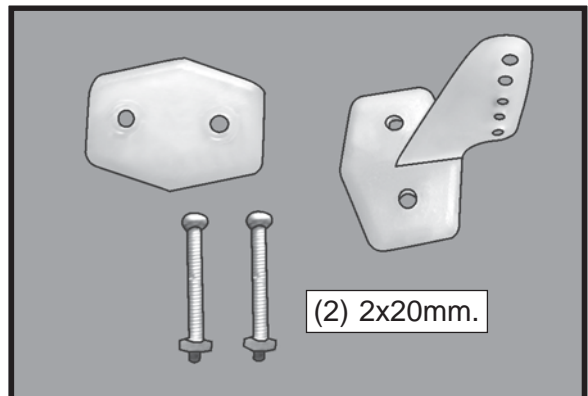

□ 3) Using a 2mm drill bit and the control horns as a guide, drill the mounting holes through the elevator halves.

□ 4) Mount the control horns then into the mounting backplates. Do not overtighten the screws or the backplates may crush the wood.

□ 5) Position the rudder control horn on the left side of the airplane.

□ 6) Install the rudder control horn using the same method as with the elevator control horns.

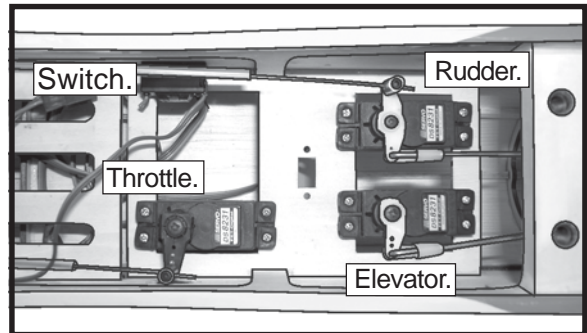
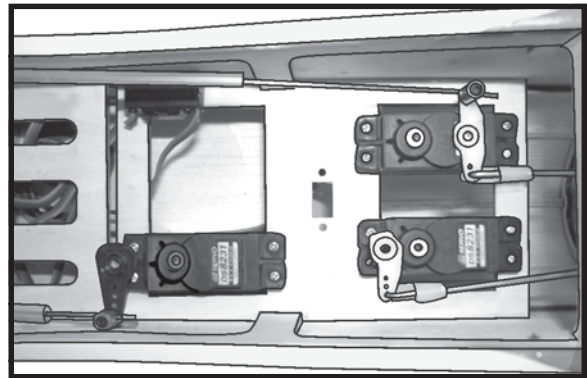
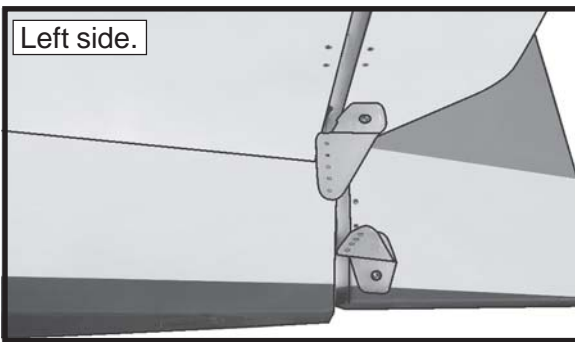

**INSTALLING THE RECEIVER AND BATTERY.**

□ 1) Plug the five servo leads and the switch lead into the receiver. Plug the battery pack lead into the switch also.

□ 2) Wrap the receiver and battery pack in the protective foam rubber to protect them from vibration

□ 3) Route the antenna out of the fuselage and secure it to the vertical stabilizer using a rubber band and a modified servo arm. See picture as below.

**ELEVATOR-RUDDER PUSHROD INSTALLATION.**

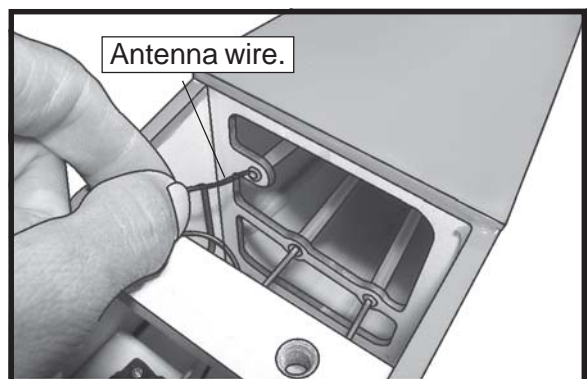
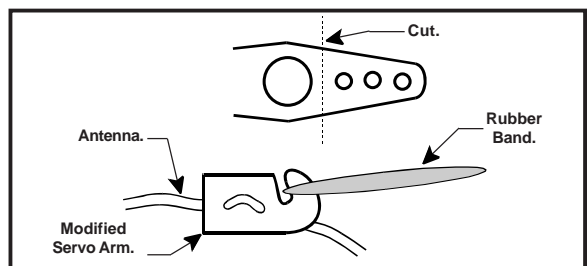
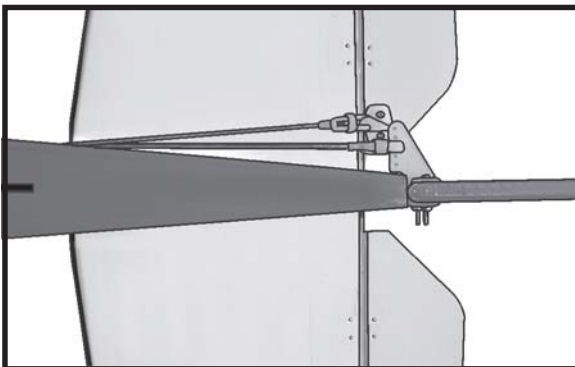
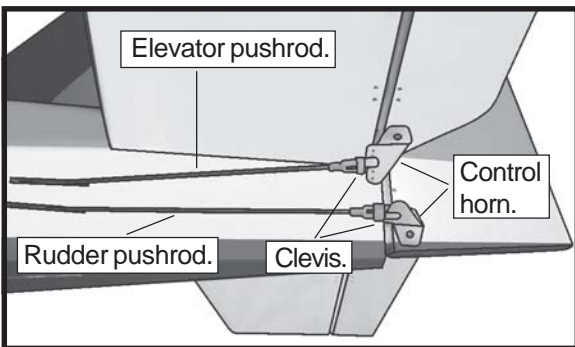



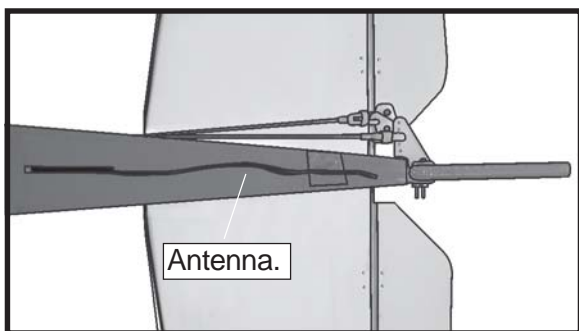

Antenna.

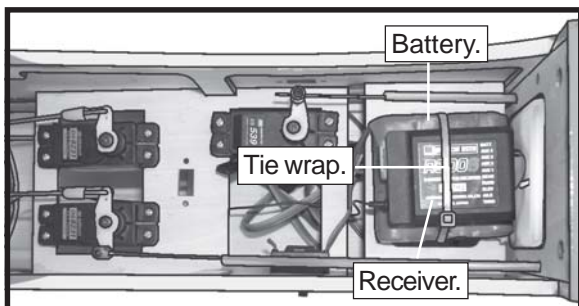

Battery.

Tie wrap.

Receiver.

### ATTACHMENT WING - FUSELAGE.

See picture below:

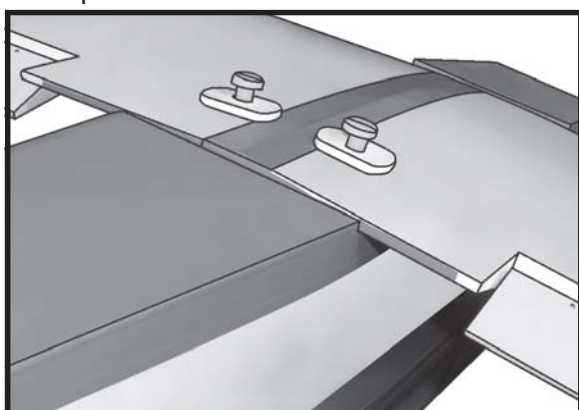

### BALANCING.

□ 1) It is critical that your airplane be balanced correctly. Improper balance will cause your plane to lose control and crash. The center of gravity is located **9cm** back from the leading edge of the wing, measured at the wing tip.

□ 2) If the nose of the plane falls, the plane is nose heavy. To correct this first move the battery pack further back in the fuselage. If this is not possible or does not correct it, stick small amounts of lead weight on the fuselage sides under the horizontal stabilizer. If the tail of the plane falls, the plane is tail heavy. To correct this, move the battery and receiver forward or if this is not possible, stick weight onto the firewall. When balanced correctly, the airplane should sit level or slightly nose down when you lift it up with your fingers.

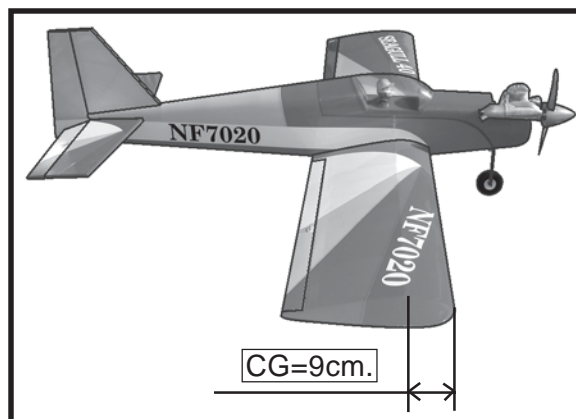

CG=9cm.

### CONTROL THROWS.

□ 1) We highly recommend setting up the **SEAGULL 40** using the control throws listed at right. We have listed control throws for both Low Rate (initial test flying) and High Rate (aerobatic flying).

□ 2) Turn on the radio system, and with the trim tabs on the transmitter in neutral, center the control surfaces by making adjustments to the clevises or adjustable servo connectors. The servo arms should be centered also.

□ 3) When the elevator, rudder and aileron control surfaces are centered, use a ruler and check the amount of the control throw in each surface. **The control throws should be measured at the widest point of each surface!**

#### INITIAL FLYING/SPORT FLYING

Ailerons:	3/8" up	3/8" down
Elevator:	3/8" up	3/8" down
Rudder:	1/2" right	1/2" left

#### AEROBATIC FLYING

Ailerons:	1/2" up	1/2" down
Elevator:	5/8" up	5/8" down
Rudder:	1" right	1" left

**Do not use the aerobatic settings for initial test flying or sport flying.**

□ 4) By moving the position of the adjustable control horn out from the control surface, you will decrease the amount of throw of that control surface. Moving the adjustable control horn toward the control surface will increase the amount of throw.

**FLIGHT PREPARATION.**

- A) Check the operation and direction of the elevator, rudder, ailerons and throttle.
  
- B) Plug in your radio system per the manufacturer's instructions and turn everything on.
  
- C) Check the elevator first. Pull back on the elevator stick. The elevator halves should move up. If they do not, flip the servo reversing switch on your transmitter to change the direction.
  
- D) Check the rudder. Looking from behind the airplane, move the rudder stick to the right. The rudder should move to the right. If it does not, flip the servo reversing switch on your transmitter to change the direction.
  
- E) Check the throttle. Moving the throttle stick forward should open the carburetor barrel. If it does not, flip the servo reversing switch on your transmitter to change the direction.
  
- F) From behind the airplane, look at the aileron on the right wing half. Move the aileron stick to the right. The right aileron should move up and the other aileron should move down. If it does not, flip the servo reversing switch on your transmitter to change the direction.

**PREFLIGHT CHECK.**

- 1) Completely charge your transmitter and receiver batteries before your first day of flying.
  
- 2) Check every bolt and every glue joint in the **SEAGULL 40** to ensure that everything is tight and well bonded.
  
- 3) Double check the balance of the airplane. Do this with the fuel tank empty.
  
- 4) Check the control surfaces. All should move in the correct direction and not bind in any way.
  
- 5) If your radio transmitter is equipped with dual rate switches double check that they are on the low rate setting for your first few flights.
  
- 6) Check to ensure the control surfaces are moving the proper amount for both low and high rate settings.
  
- 7) Check the receiver antenna. It should be fully extended and not coiled up inside the fuselage.
  
- 8) Properly balance the propeller. An out of balance propeller will cause excessive vibration which could lead to engine and/or airframe failure.

***We wish you many safe and enjoyable flights with your SEAGULL 40 LOW WING TRAINER.***