



# Master Scale kit Edition AT-6 Texan 63" 10-15cc

Code : MSK01.110

## ASSEMBLY MANUAL

“Graphics and specifications may change without notice”.



### Specifications:

Wingspan-----	62.9 in-----	159 cm.
Length-----	43.6 in-----	110.8 cm.
Wing area-----	620 sq.in-----	40.0 sq.dm.
Weight-----	6.2 - 7.7 lbs-----	2.8 - 3.5 kg.
Recommended R/C -----	10-15cc.	
	.40 - .52 cu.in / 2 stroke.	
	.72 - .82 cu.in / 4 stroke.	

Radio System required 6 channels with 6 servos.



## INTRODUCTION

- Congratulations and thank you for purchasing the **Master Scale kit Edition AT-6 Texan 63” 10-15cc**. We are pleased to bring you this scale **AT-6 Texan 63” 10-15cc**. With this kit you can achieve whatever level of detail you like. Just by following the instruction and finishing the plane in scale-looking trim scheme, beginning scale modelers will end up with a model that very much represents and full-size P-51. Experienced builders will find ways to add even more detail, making the **Master Scale kit Edition AT-6 Texan 63” 10-15cc** competitive in scale contents.

## GETTING PREPARE TO BUILD AS

- Here is a list of supplies you should have on hand while you are building. Some of these are optional. Use your own experience to decide what you need.

- Getting prepare to build as:
- Flat Iron
- White Glue
- CA Glue
- Epoxy Glue
- Ruler
- Cutter
- Sandpaper Bar
- Aluminum Square Fixed Tool

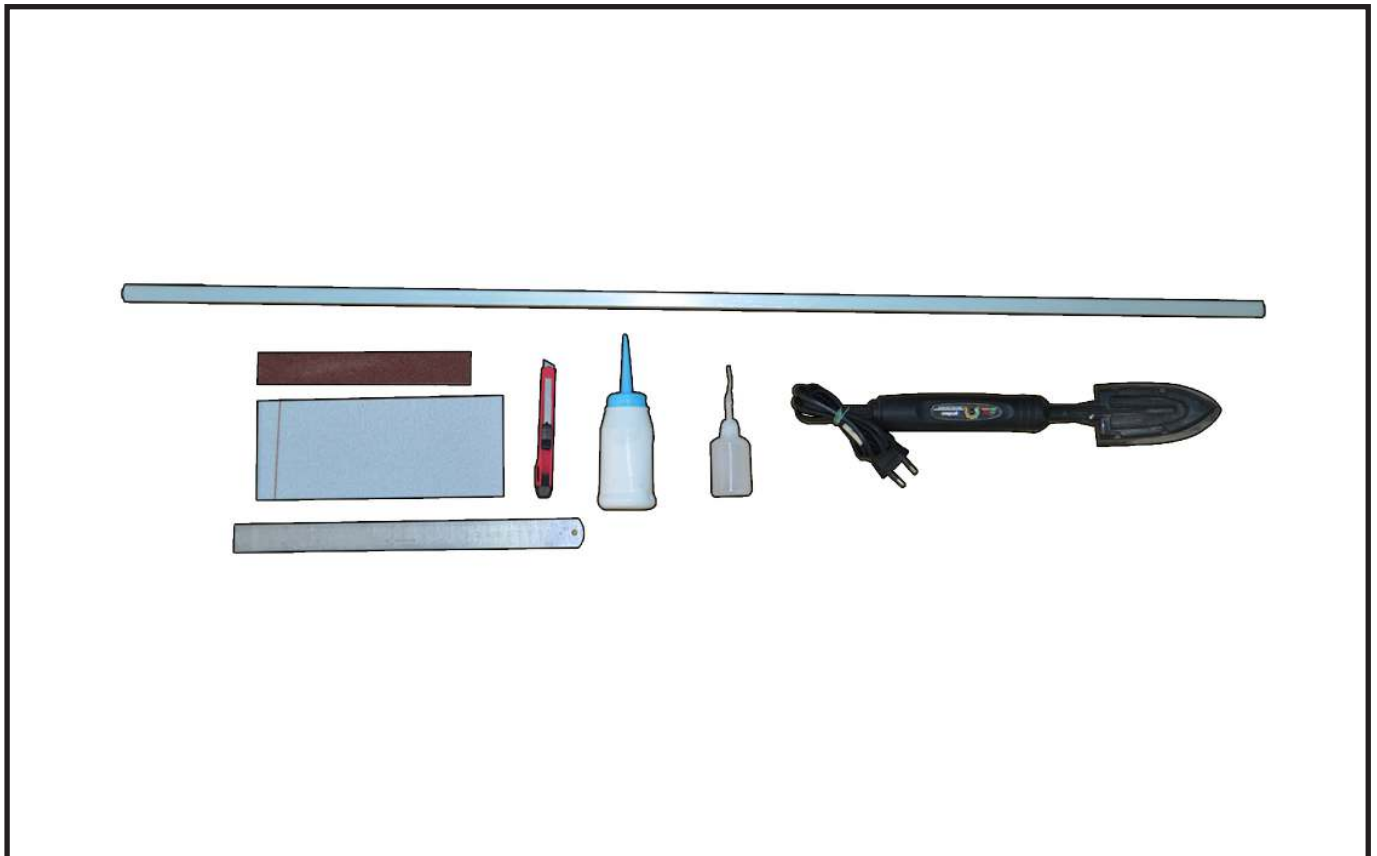

# DIE-CUT PATTERNS

2.7mm balsa plywood 1000mmx250mm (1 per kit)

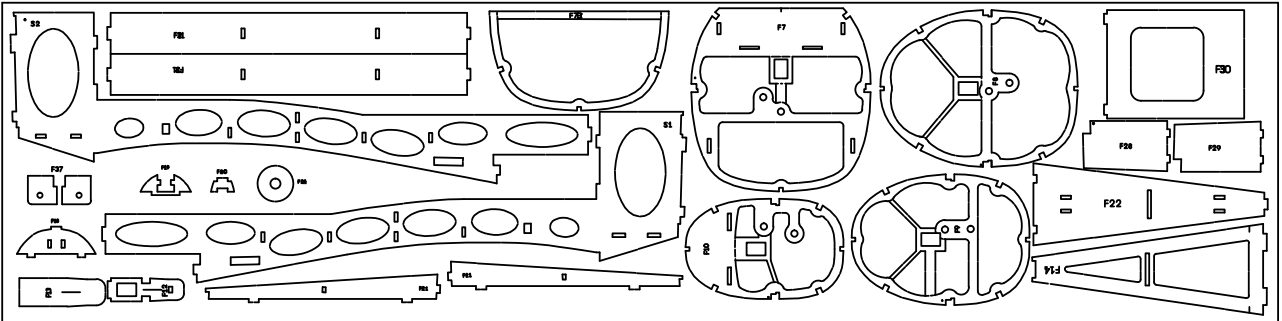

2.7mm balsa plywood 1000mmx250mm (1 per kit)

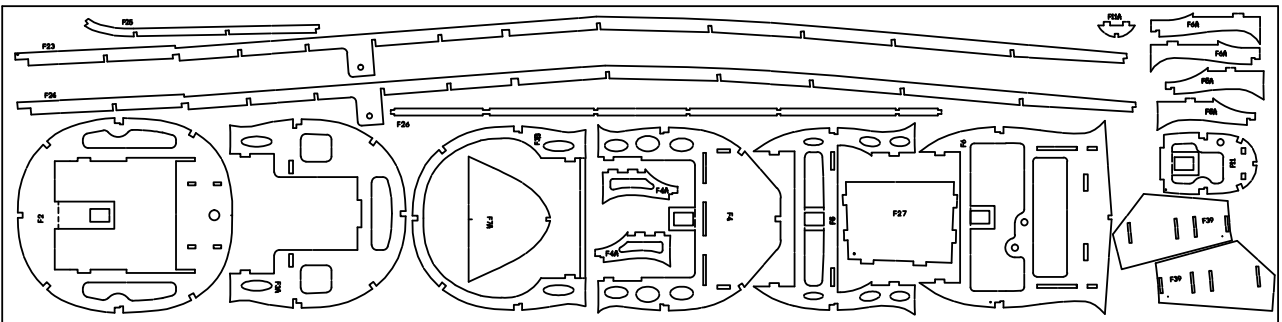

2.7mm balsa plywood 1000mmx250mm (1 per kit)

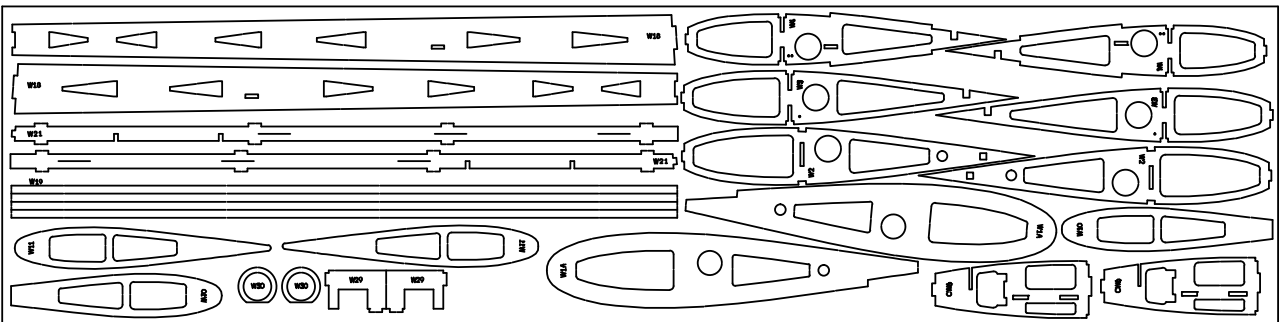

2.7mm balsa plywood 1000mmx250mm (1 per kit)

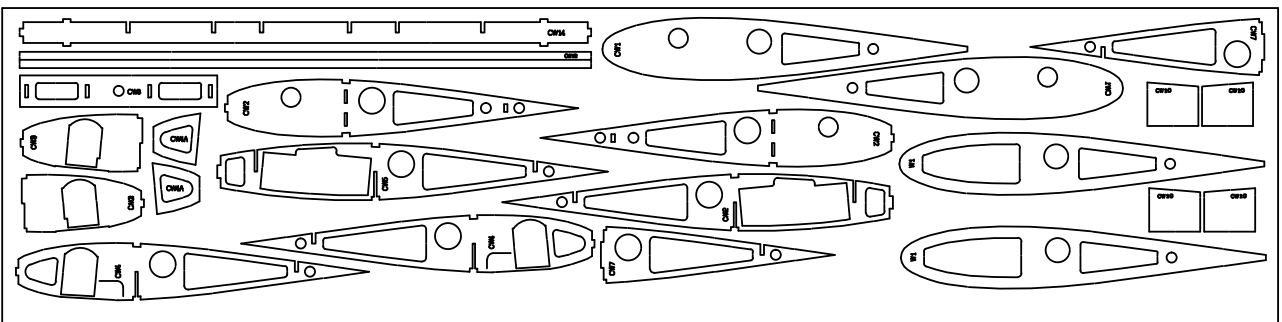



# DIE-CUT PATTERNS

2mm balsa sheet 100mmx100mm (2 per kit)

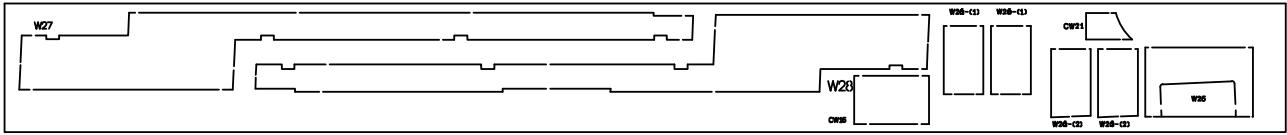

2mm balsa sheet 100mmx100mm (2 per kit)

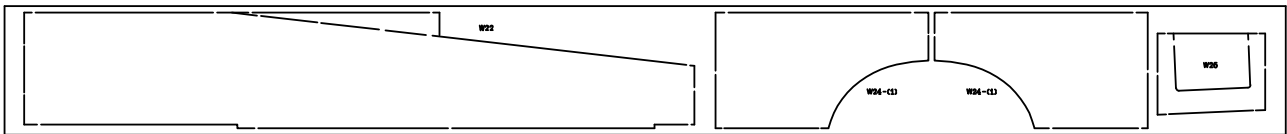

2mm balsa sheet 1000mmx100mm (2 per kit)

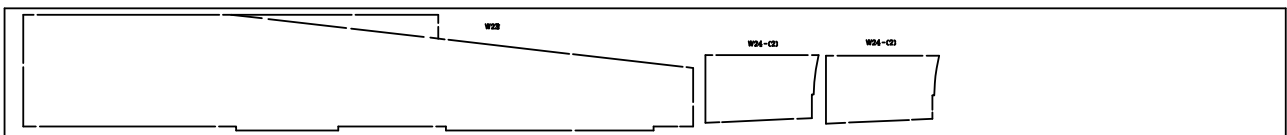

2mm balsa sheet 1000mmx100mm (1 per kit)

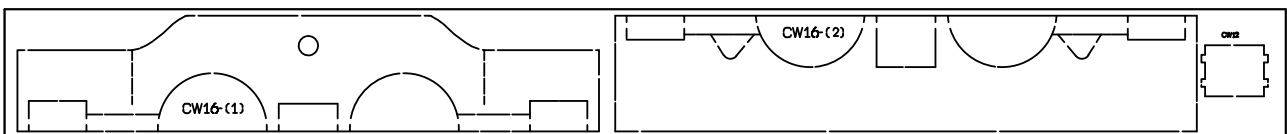

2mm balsa sheet 1000mmx100mm (1 per kit)

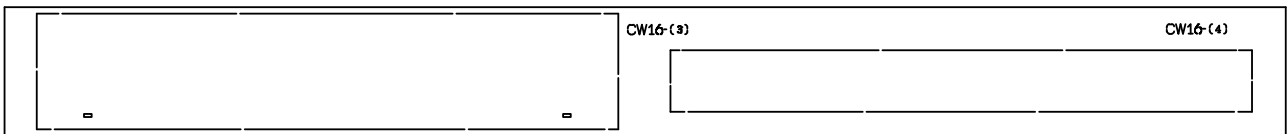

2mm balsa sheet 1000mmx100mm (1 per kit)

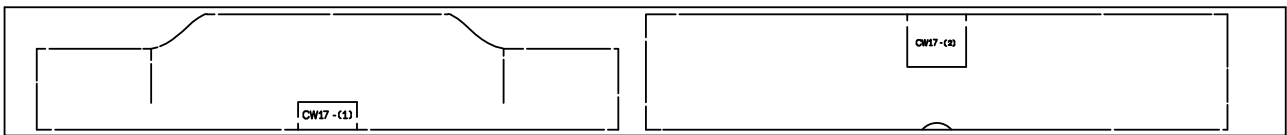

2mm balsa sheet 1000mmx100mm (1 per kit)

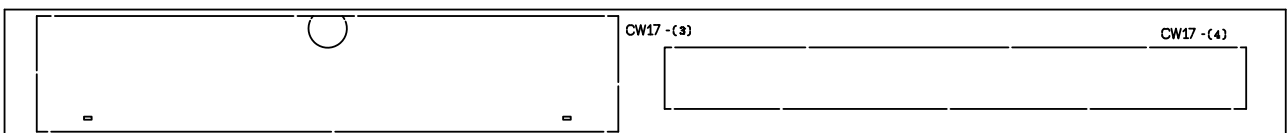

### DIE-CUT PATTERNS

2mm balsa sheet 1000mmx100mmm (2 per kit)

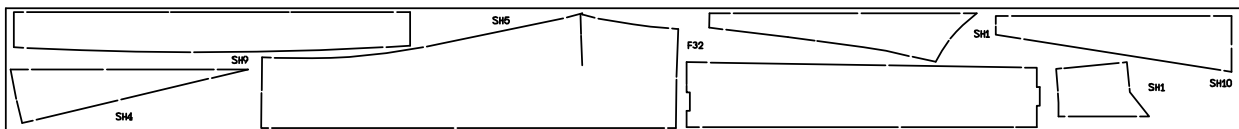

2mm balsa sheet 1000mmx100mmm (2 per kit)



2mm balsa sheet 1000mmx100mmm (1 per kit)

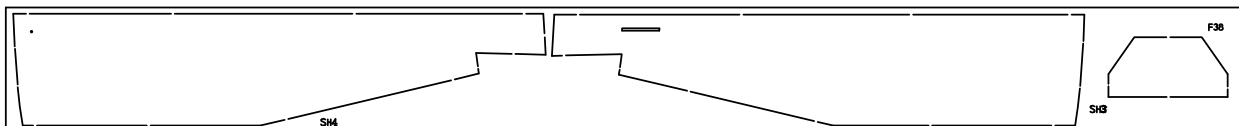

2mm balsa sheet 1000mmx100mmm (1 per kit)

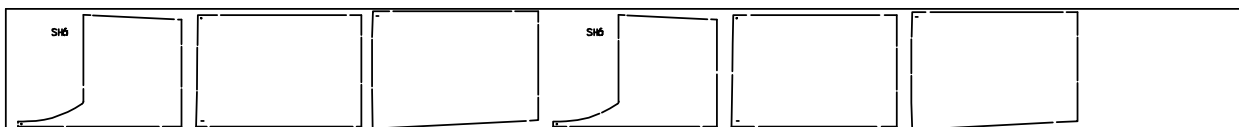

### PREPARE BEFORE BUILDING

Please kindly see the plan drawing and compare to die-cut pattern to pick the parts of fuselage, the parts of wing, the parts of rudder and stabilizer. They were shown by the difference name code. Please lightly remove the die-cut parts by paper cutter blade. Please make lightly clean smoke stains on them by a sanding tool so that the glue absorbs quickly.

## BUILD THE FUSELAGE

As if you were sitting in the cockpit and distinguish left side and right side of model. **NOTE: Regulations for the right side. It is small point which was marked on each former and fuselage side.**

### \* Firewall

Locate and assemble 3 layers of engine mount include F1A and F1B (2pcs) in order by epoxy as photo shown (photo 1). **NOTE: The small point is regulations for the right side. And then, use heavy flat thing pressed on F1 block (3 layers assembled) until epoxy dries to ensure firewall block is not warped.**

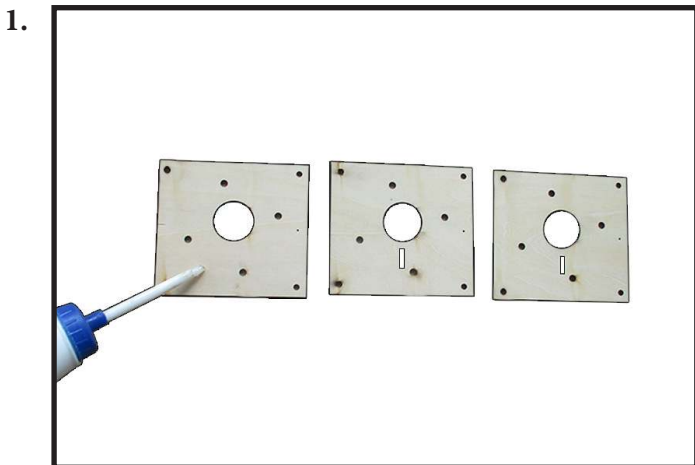

Locate and assemble engine mount F33 to firewall by epoxy glue. (Photo 2). **NOTE: The small point is regulations for the right side.**

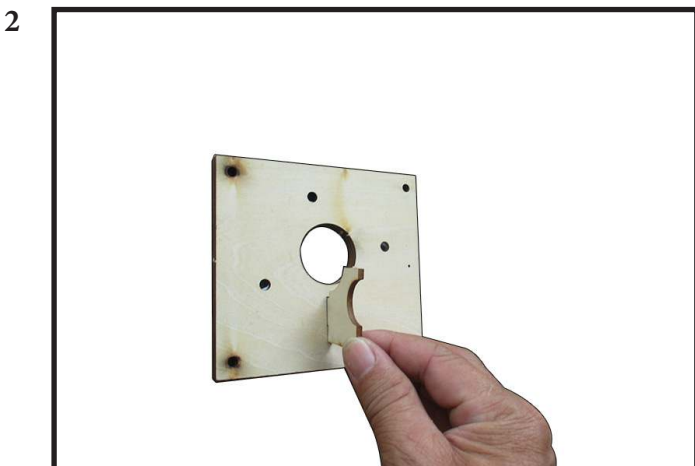

Locate and assemble F1C, F1D, F1E, F1F to firewall F1 by epoxy glue. (Photo 3,4). **NOTE: The small point is regulations for the right side.**

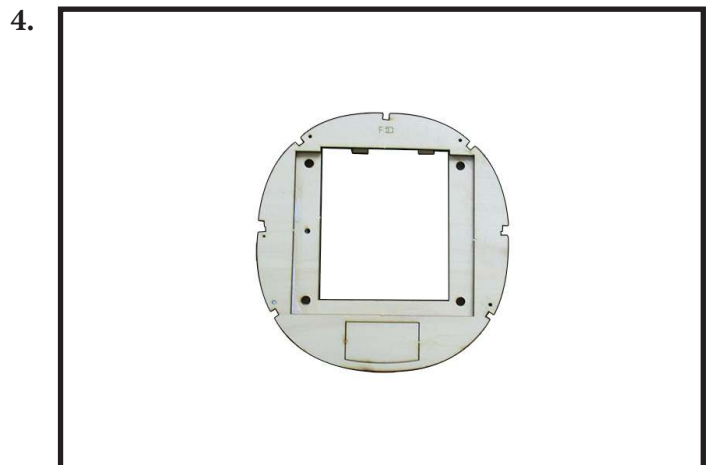
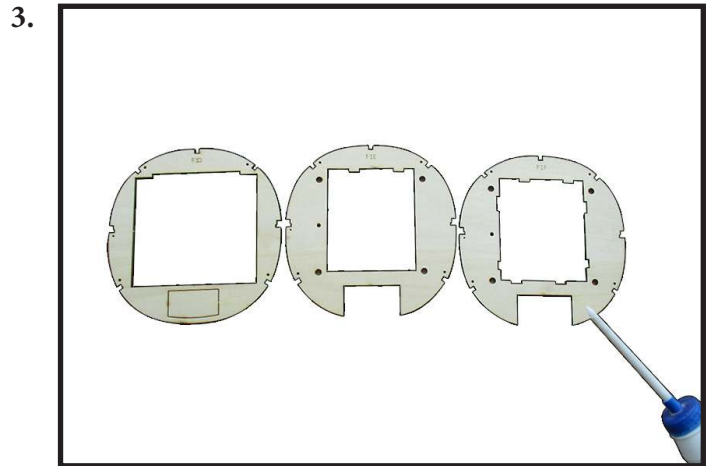

Locate and assemble F2A to F2 by epoxy glue. (Photo 5,6).

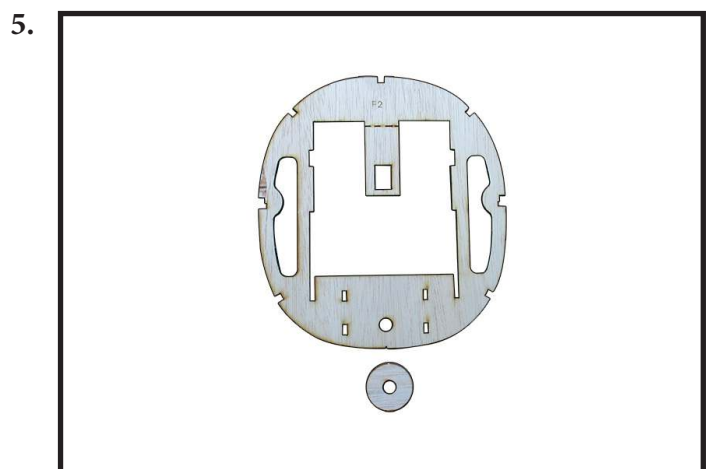

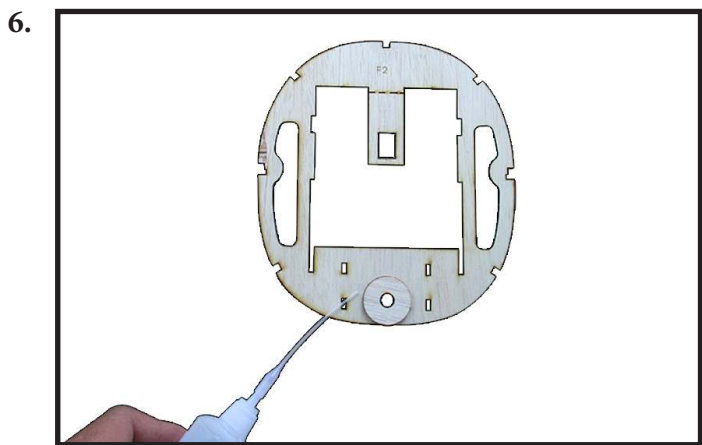

Locate and assemble wing mount F35A to F35B by epoxy glue. (Photo 7,8).

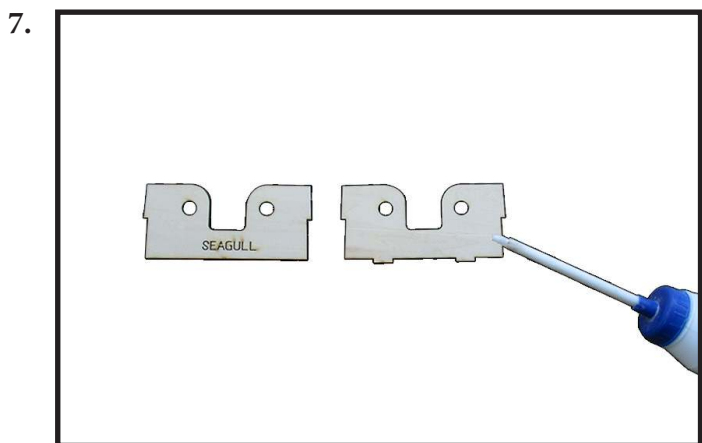

Locate and assemble F7B behind F7 by epoxy glue. (Photo 9,10). **NOTE: The small point is regulations for the right side.**

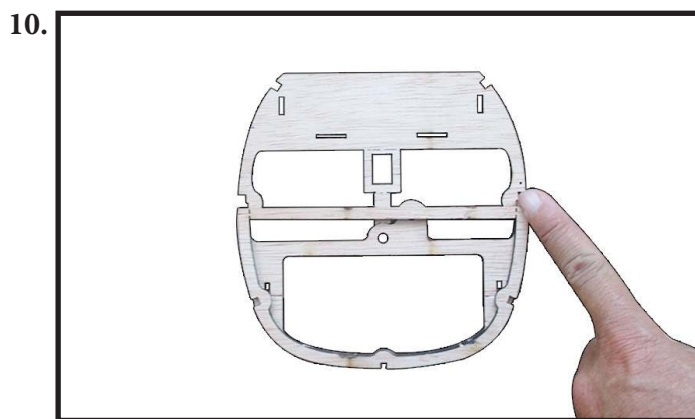
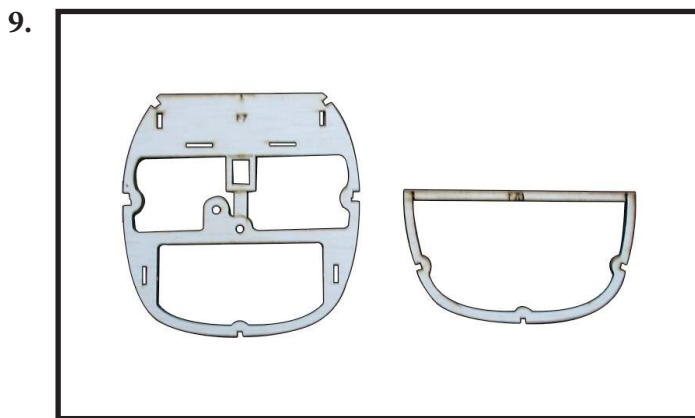

Locate and assemble F3B behind F3A by epoxy glue. (Photo 11,12).

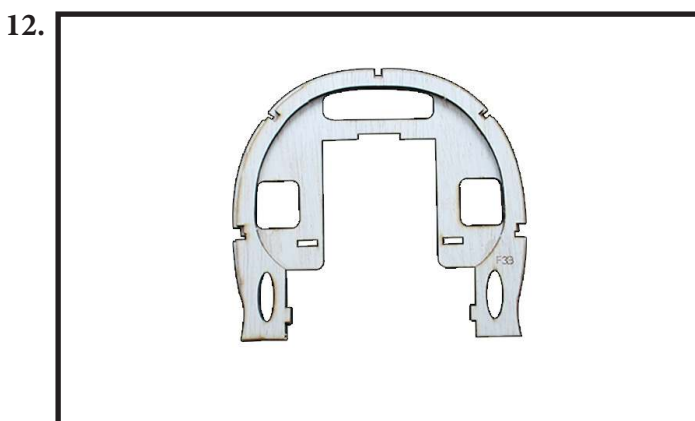
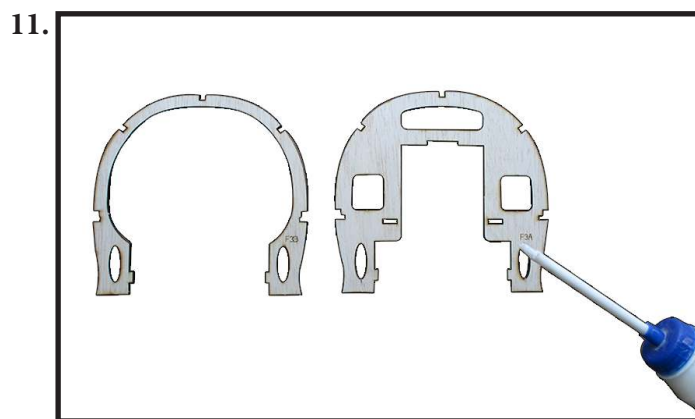



Locate and assemble tab F34A to F34B (include 4 sets) by epoxy glue. Then assemble them to F1C (Photo 13,14).

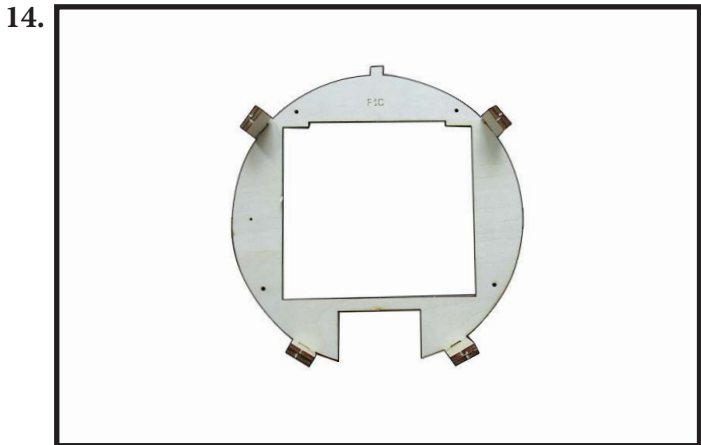
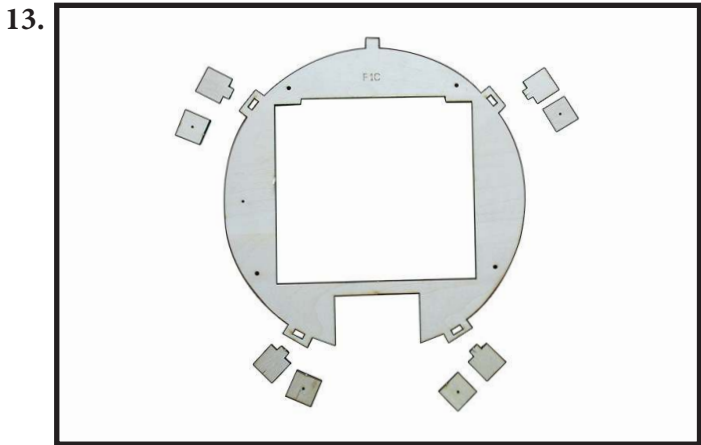

Prepare all the part as (photo 15).

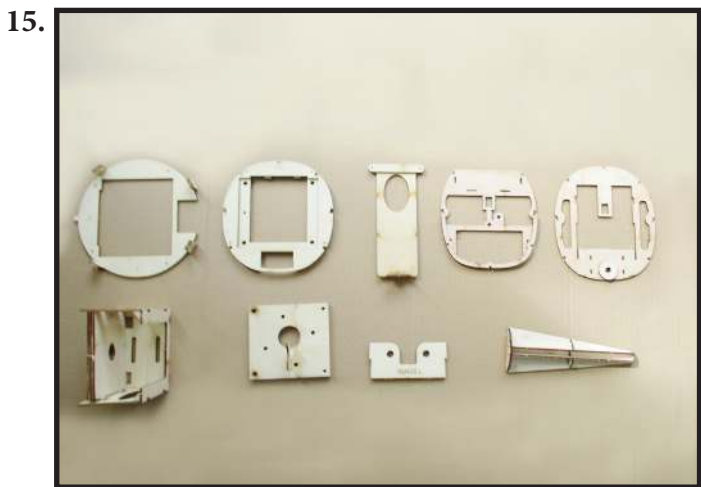

\* Assemble hard- wear to the position of holes were drilled available.

Locate and assemble Pronged T-Nuts M4 to engine holes of F1 (firewall) ; as photo shown (photo 16).

Pronged T-Nuts M3 to holes of F37 as photo shown (photo 16).

The next assembly is Plastic Well Nut M6 to holes of F35 (wing mount) as photo shown (photo 16).

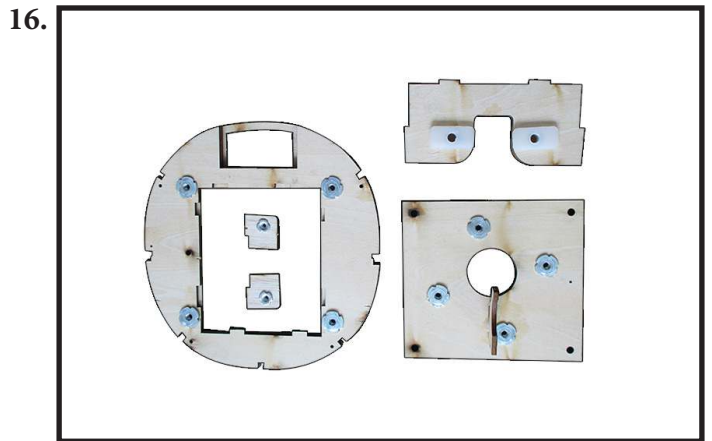

\* Electric Motor mount.

Please skip this step if you use the gasoline engine.

Prepare all the part for motor mount as (photo 17).

MO1 (3pcs); MO2; MO3 (2pcs); MO4

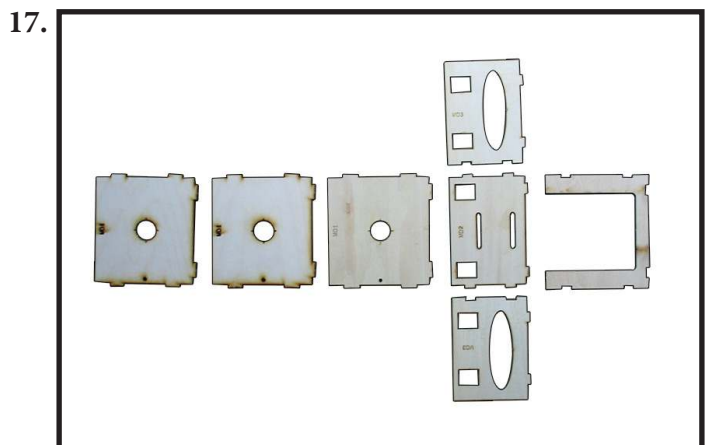

Locate and apply MO1 (3pcs) together by epoxy glue. (Photo 18).

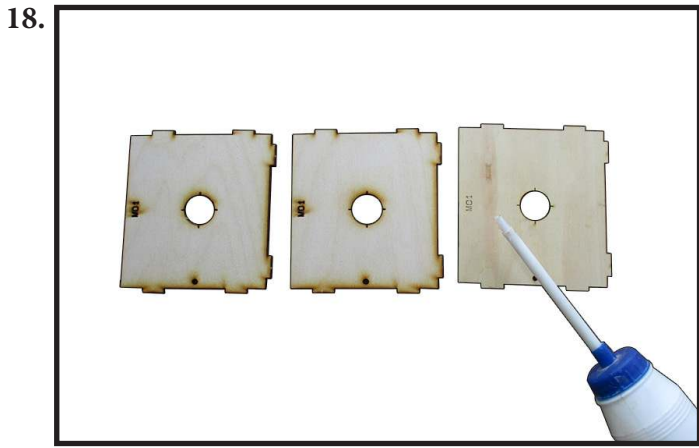

Locate and assemble MO1, MO2, MO3, MO4 by epoxy glue to become a mount box. Then, reinforce by two triangle balsa bars. (Photo 19,20).

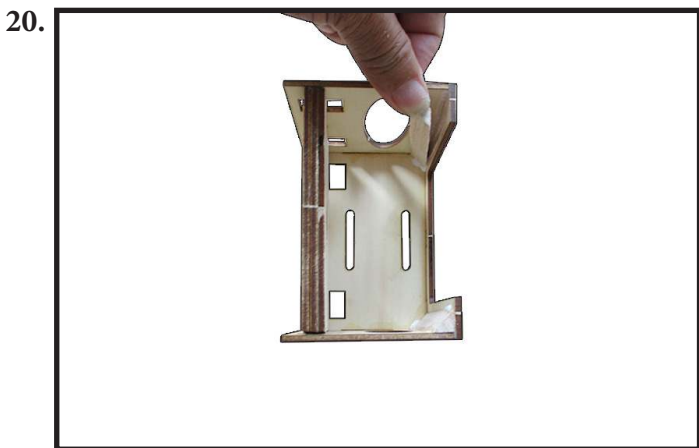
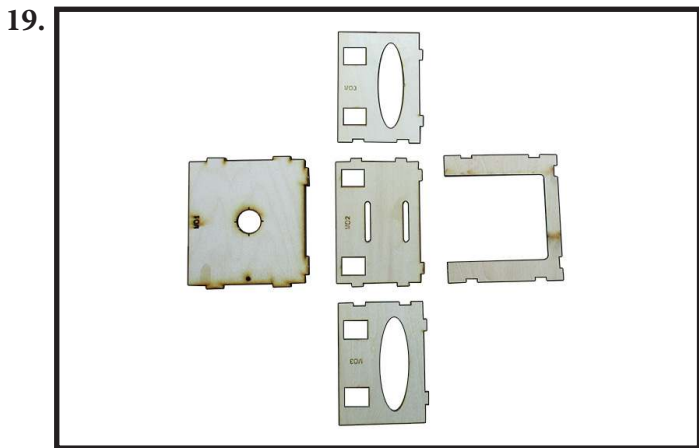

Locate and assemble FS3, FS4 to FS2 by epoxy glue. (Photo 21,22).

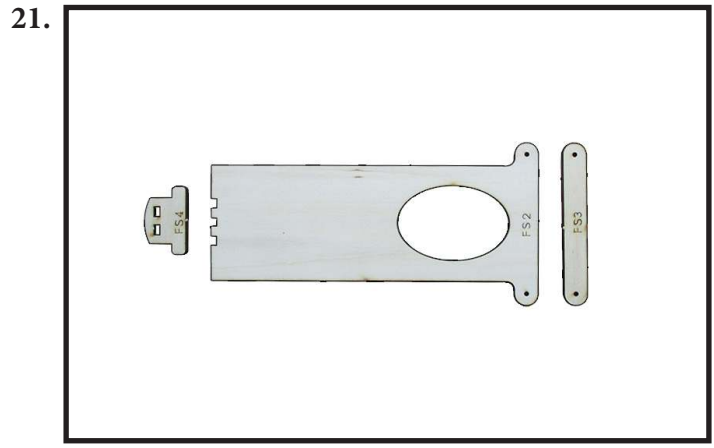

**\* Build the fuselage.**

As shown (photo 23). All parts are available for fuselage assembly.

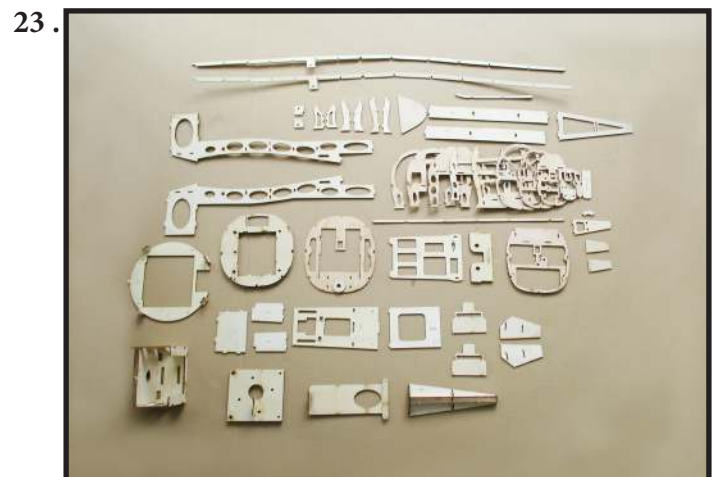

Pick some parts as shown (photo 24). Include S1, S2, F1, F2, F3, F4, F5, F6, F7.

24.

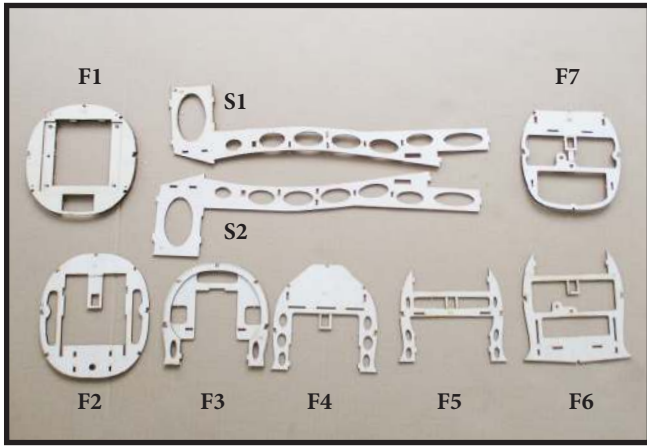

Locate and assemble F2 to S2 as (Photo 25,26).

**NOTE: The small point is regulations for the right side.**

25.

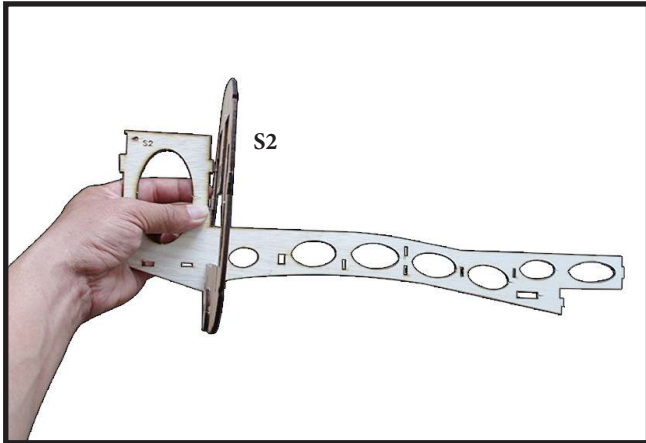

26.

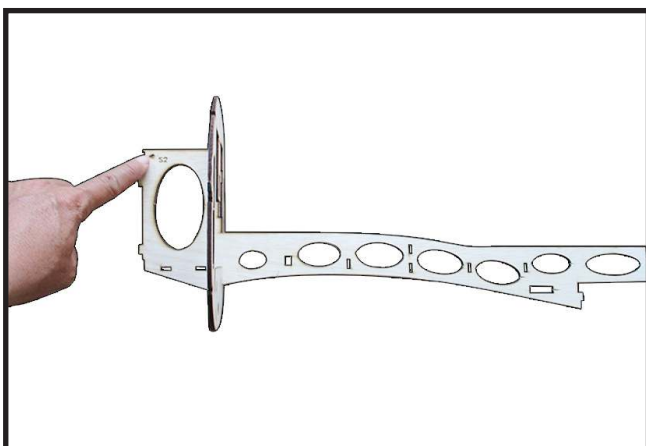

Locate and assemble F3 to S2 as (Photo 27).

27.

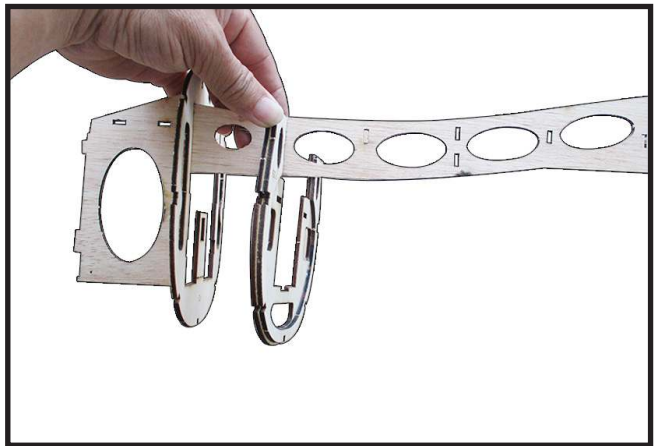

Locate and assemble F4, F5 to S2 (the right fuselage side) as (Photo 28).

28.



Locate and assemble F2, F3, F4, F5 to S1 (the left fuselage side) as (Photo 29).

29.

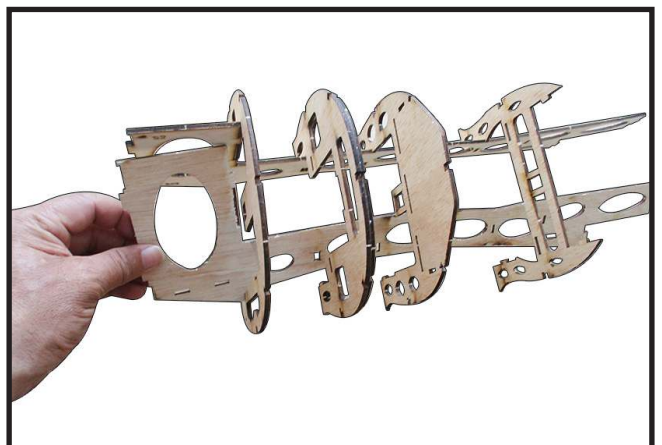

Locate and assemble F6 to S1, S2 as (photo 30).

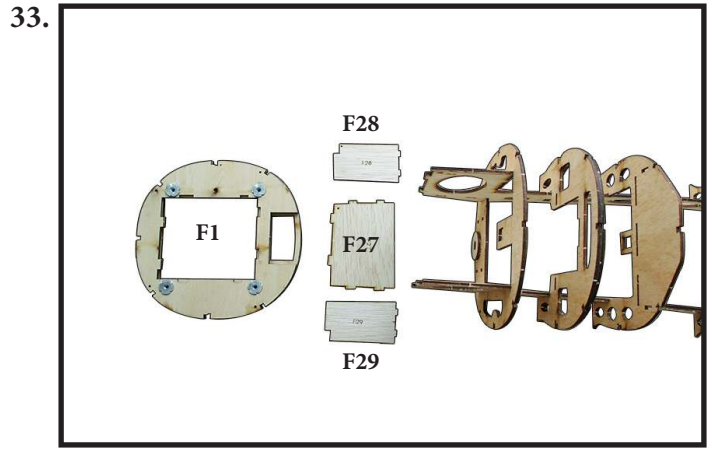
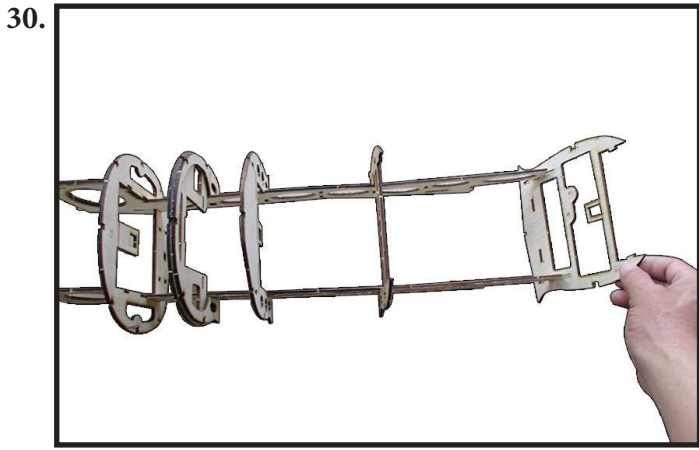

Locate and assemble F7 to S1, S2 as (photo 31, 32).

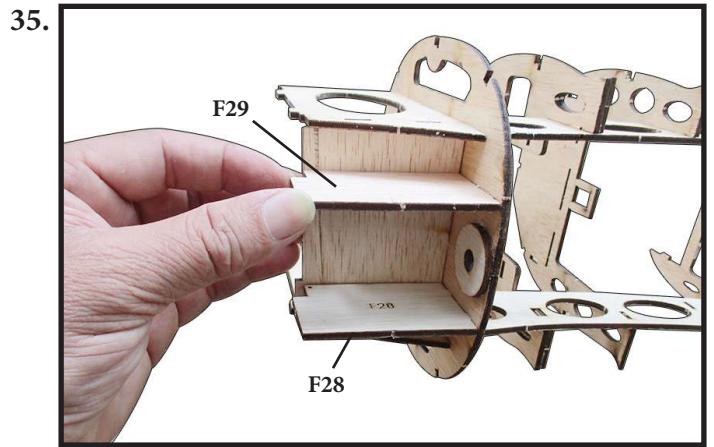
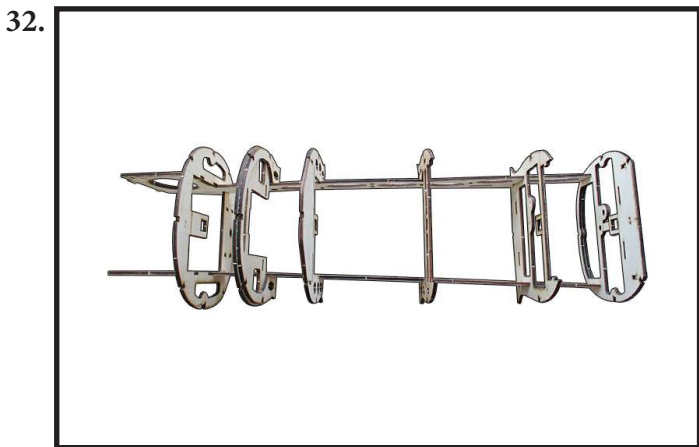
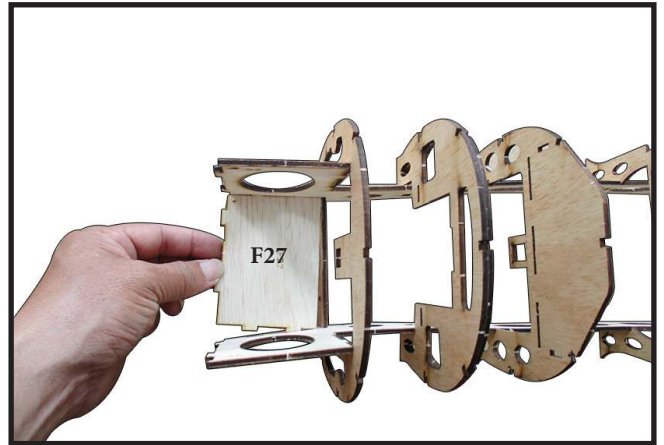
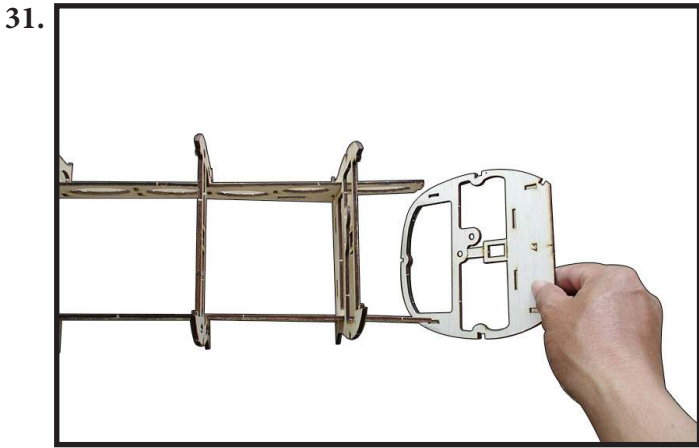

Locate and assemble F1, F27, F28, F29 to S1, S2 as (photo 33,34,35).

Locate and assemble F1 to S1, S2 as (photo 36, 37).

**NOTE: The small point is regulations for the right side**

**NOTE: The small point is regulations for the right side.**

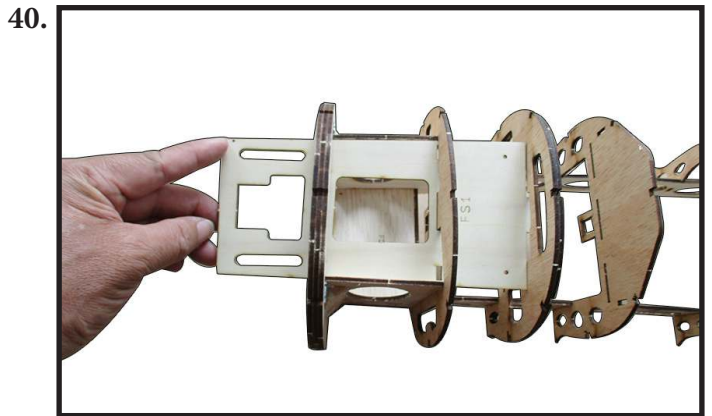
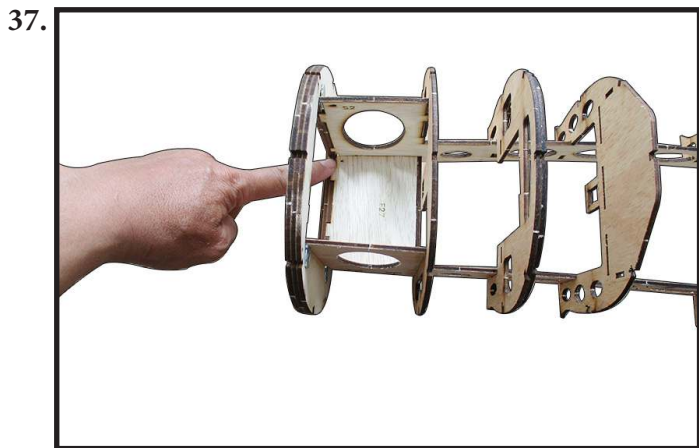
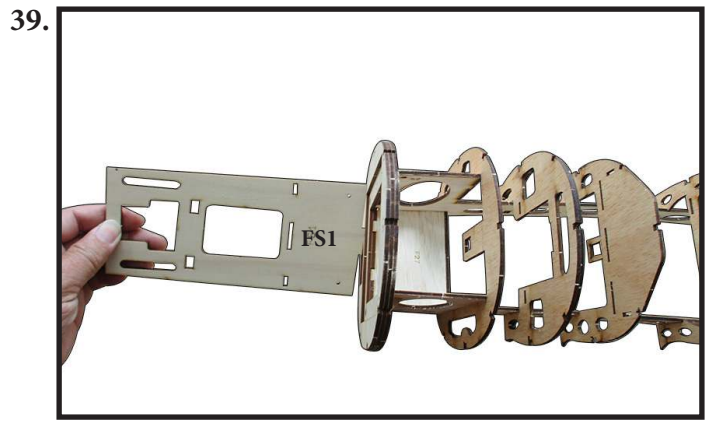
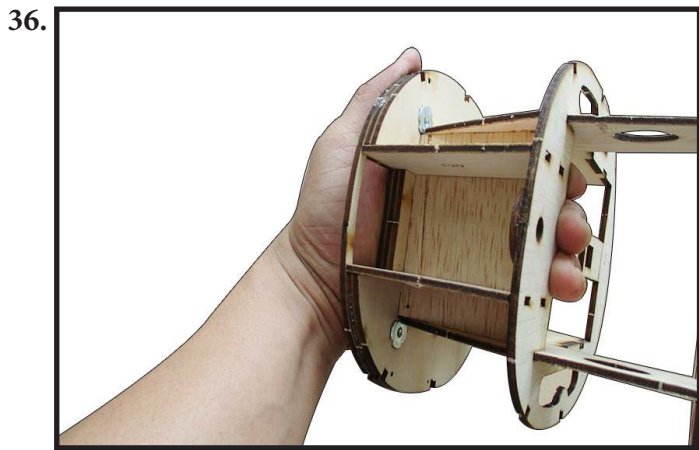

Reinforce the triangle balsa bar at outside where the perpendicular angle of F1 and S1; the perpendicular angle of F1 and S2 so that ensure strong for F1 as (photo 38).

Locate and assemble wing mount F35 (include F35A, F35B) to fuselage by epoxy as (photo 41,42).

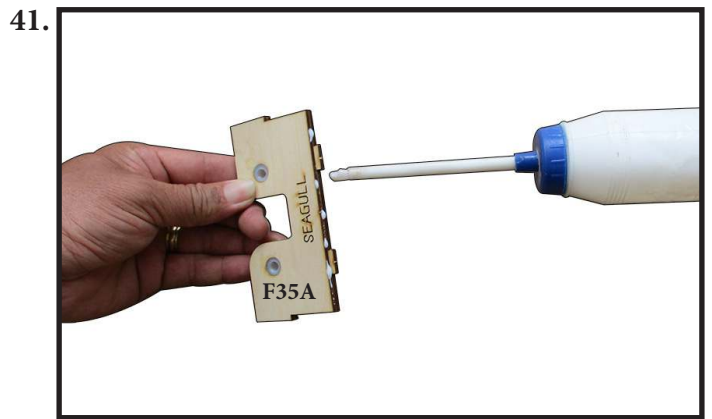
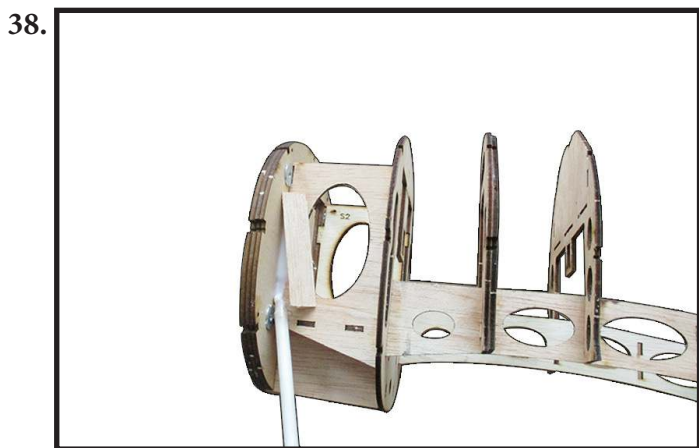

Locate and assemble servo mount FS1 to fuselage as (photo 39,40).

**NOTE: The small point is regulations for the right side.**

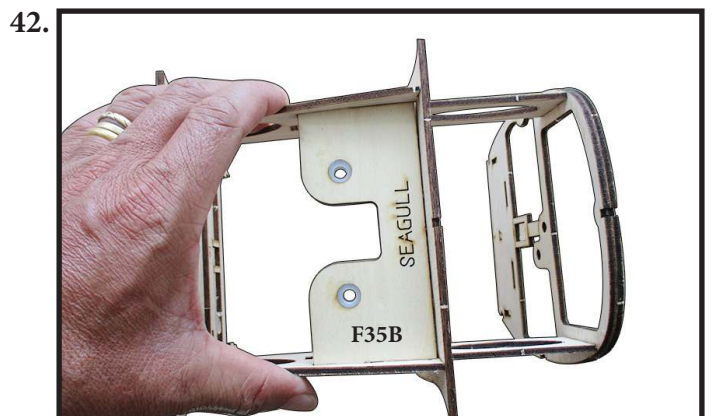

Locate and assemble F31 (left and right) to fuselage by epoxy as (photo 43).

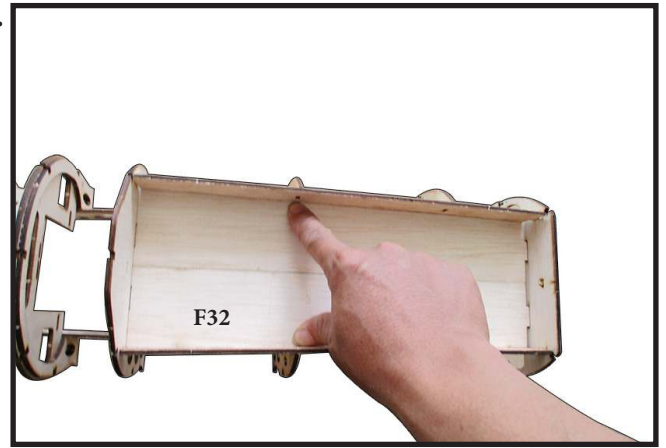
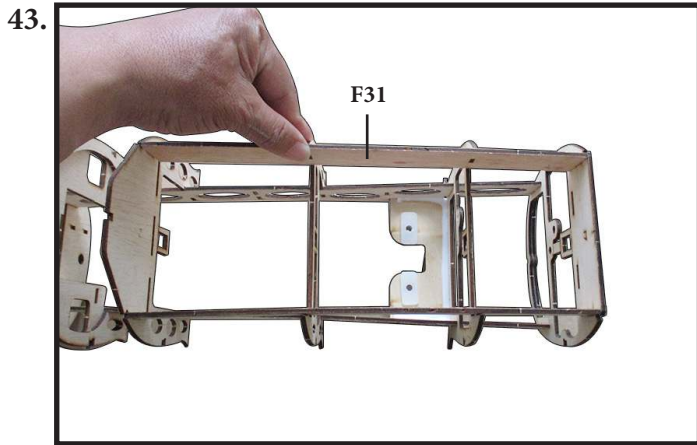

Locate and assemble F4A, F5A to fuselage as (photo 47).

Weld two half of sheet F32 to become a sheet by CA glue. (Photo 44,45).

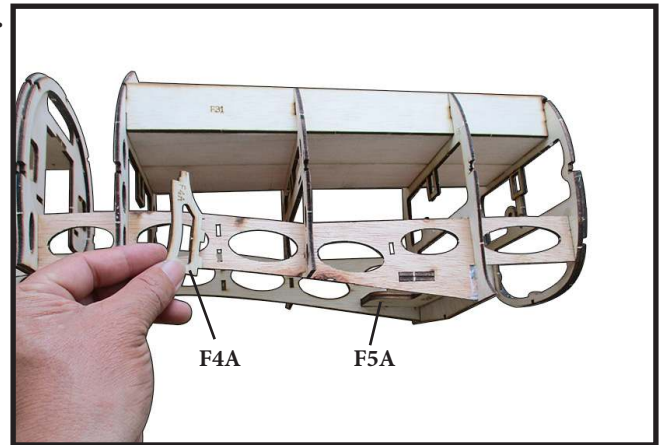

Attach the aluminum square tool bar to the square hole at each former. It is through along to fuselage to adjust to fuselage straight. Remove it after finishing covering balsa sheet for fuselage (photo 48).



Locate and assemble F32 to fuselage as (photo 46).

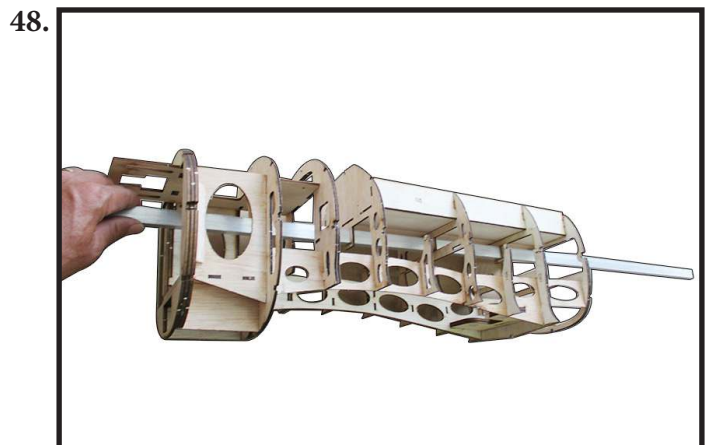

Pick some parts as shown (photo 49) so that prepare for assemble rear of fuselage.

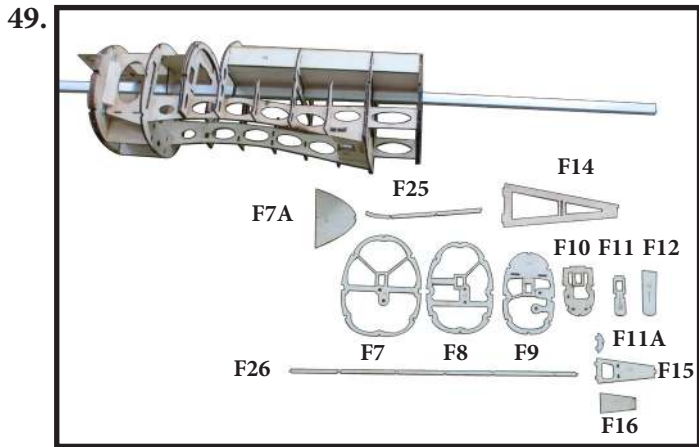

Locate and assemble the former, one after another in order F7- F12, they are gone through the aluminum square strip as (Photo 50). **NOTE: The small point is regulations for the right side.**

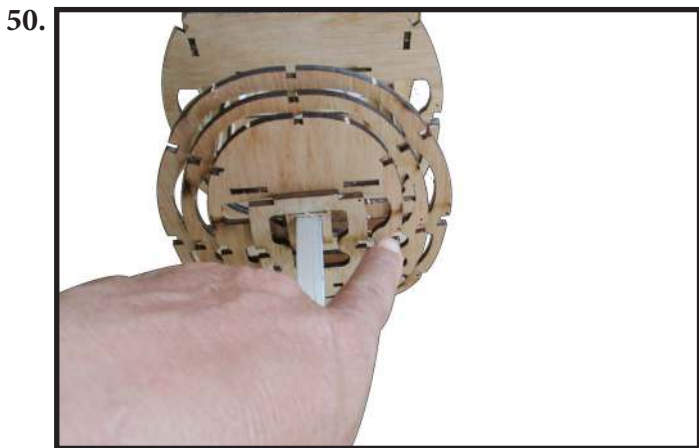

Locate and assemble F23 (right side) to one after another in order F7- F12. Then, assemble F24 (left side). (Photo 51,52).

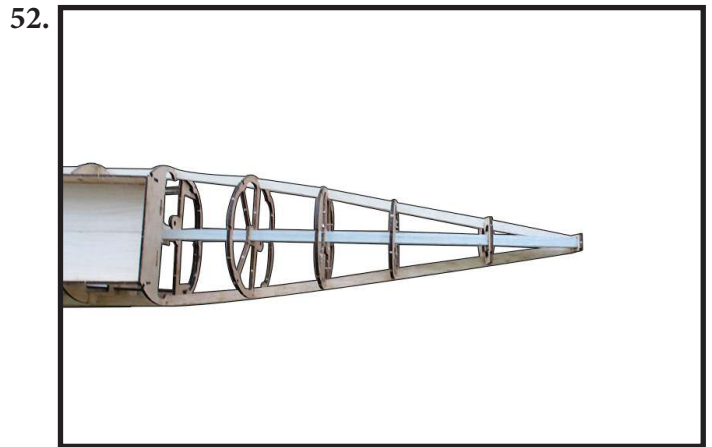
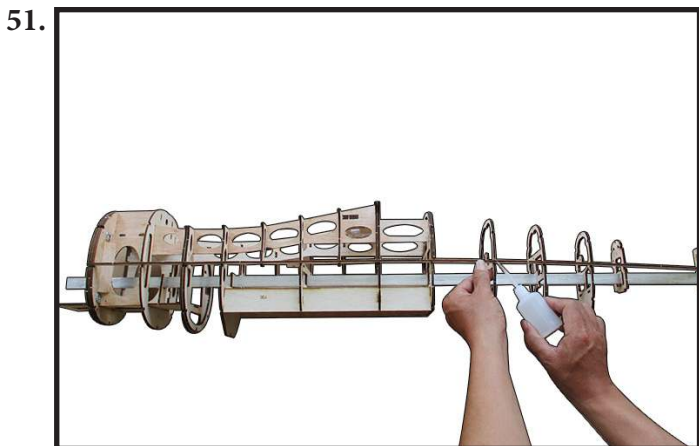

Locate and assemble F14A as (photo 53).

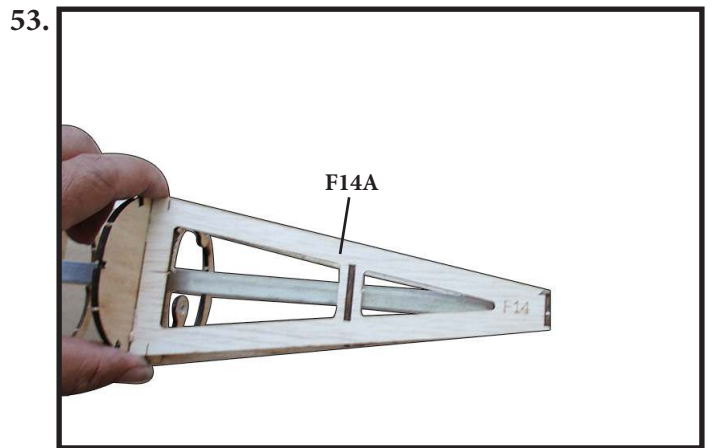

Locate and assemble F25 as (photo 54).

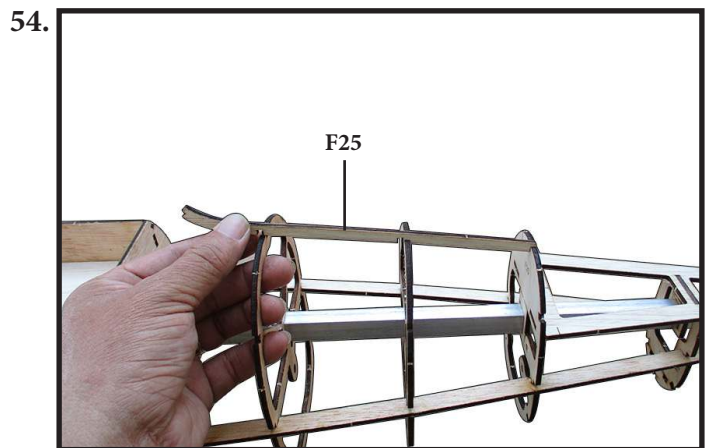

Locate and assemble F7A as (photo 55).

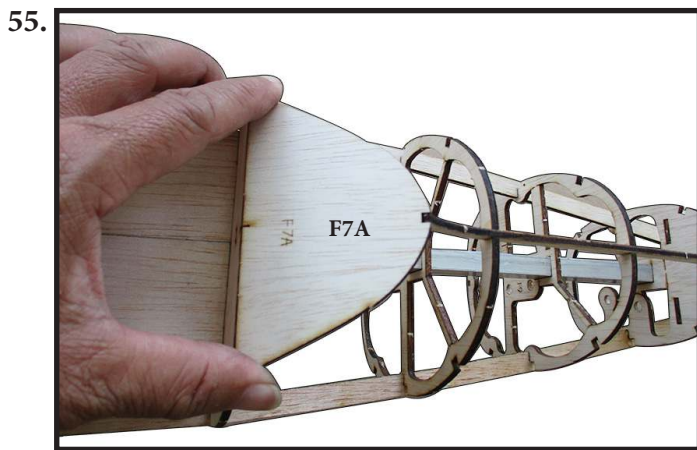

Locate and assemble F26 as (photo 56).

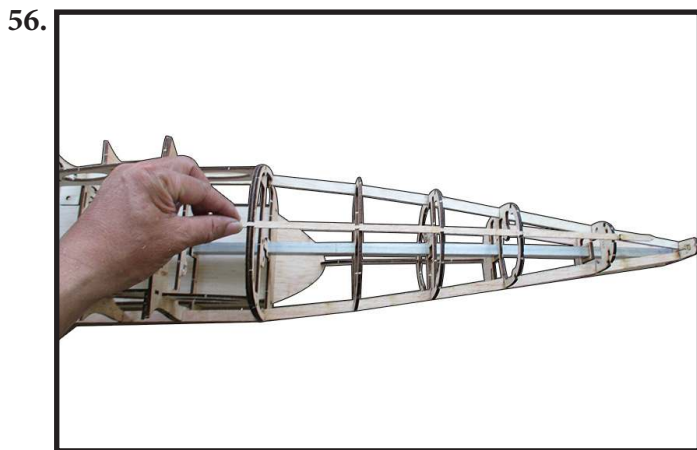
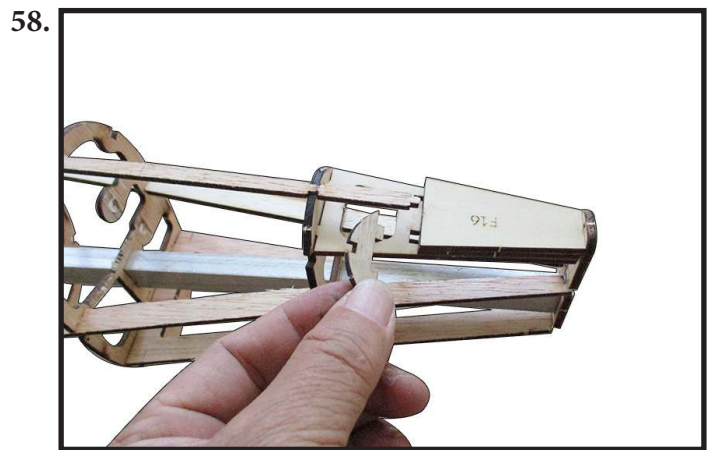

Locate and assemble F15, F16 as (photo 57).



Locate and assemble F37 as (photo 60).



Locate and assemble F11A as (photo 58,59).



Locate and assemble FS5 (servo mount) as (photo 61).



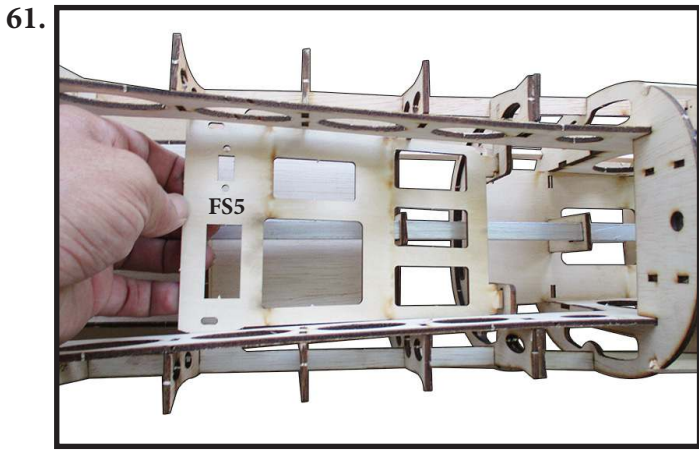

Attach the plastic pushrod tube to the pushrod hole at each former fuselage as photo shown (photo 62).

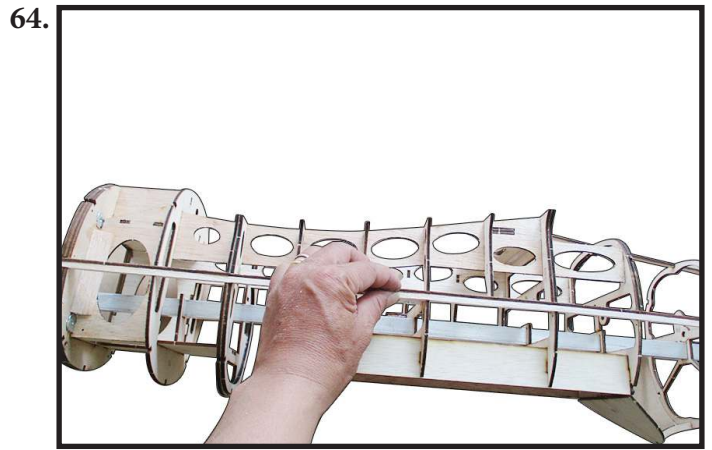

\* **Sheeting of the fuselage (cover to the ribs of fuselage).**

Weld together three difference pieces SH1 become a sheet (left and right) by CA glue as photo shown. (photo 65,66).



Assemble the 4x4mm balsa strip (4pcs) to each former fuselage purpose link all former fuselage and support for covering sheet as (photo 63,64).

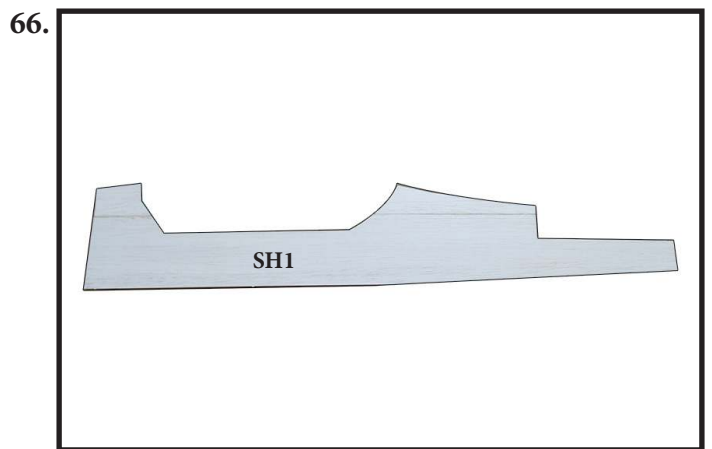
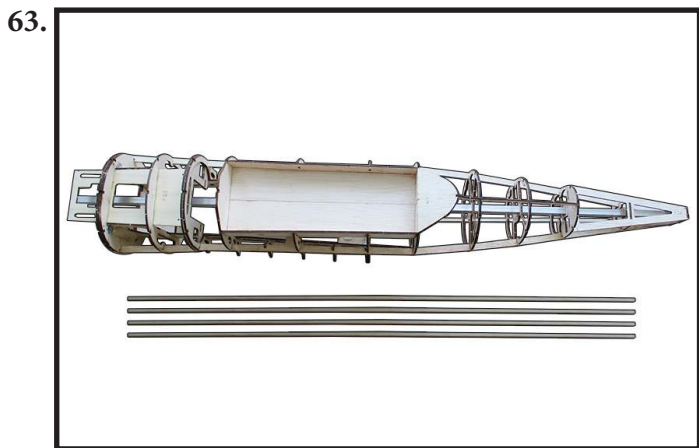
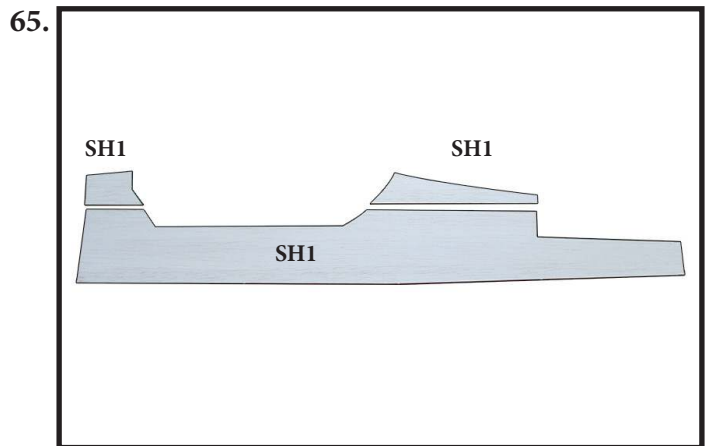

Put the sheet SH1 at area of fuselage as photo shown (photo 67,68).

Bend the balsa sheet go to the curve of top area. 70. Then, add CA glue and use the finger at this place until the glue dries as photo shown .

Do the same for the other half of the top area, so that the balsa sheet keep fixed fuselage.

Then, add a little epoxy glue inside at intersect place of all ribs and sheet.

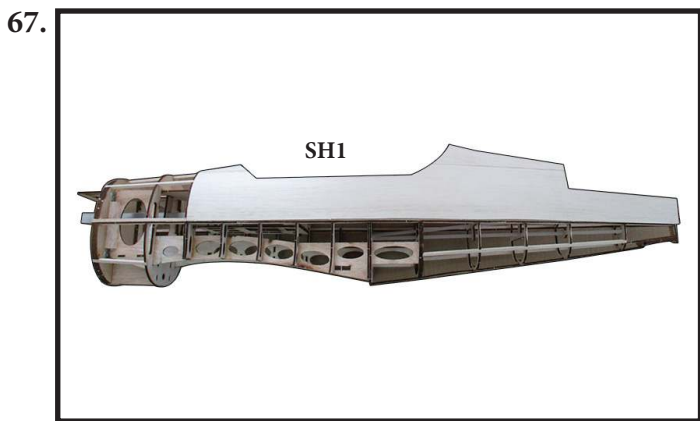
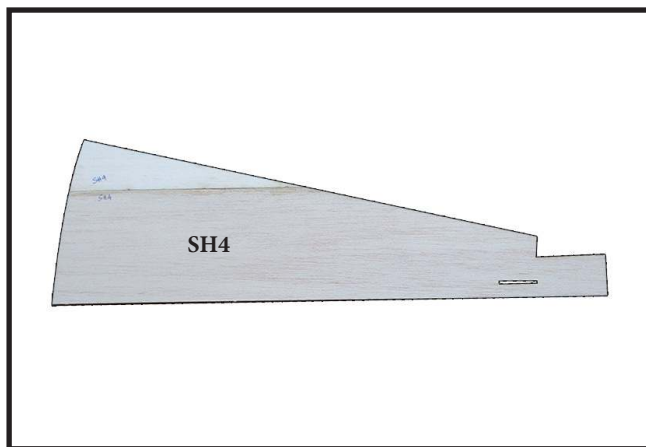

Put the sheet SH4 at area of fuselage as photo shown (photo 71).

Bend the balsa sheet go to the curve of bottom area. Then, add CA glue and use the finger at this place until the glue dries as photo shown.

Do the same for the other half of the bottom area, so that the balsa sheet keep fixed fuselage.

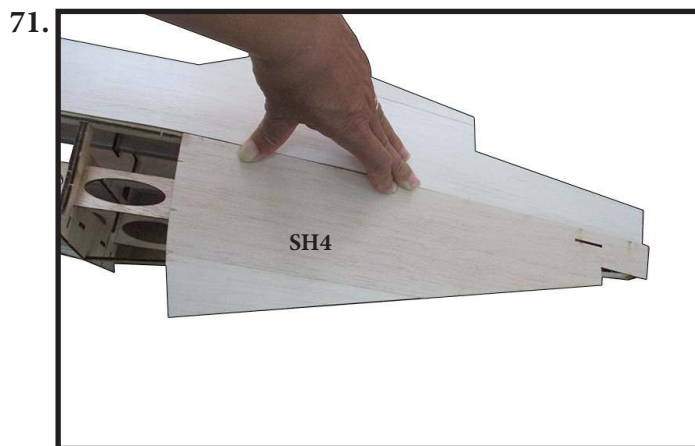
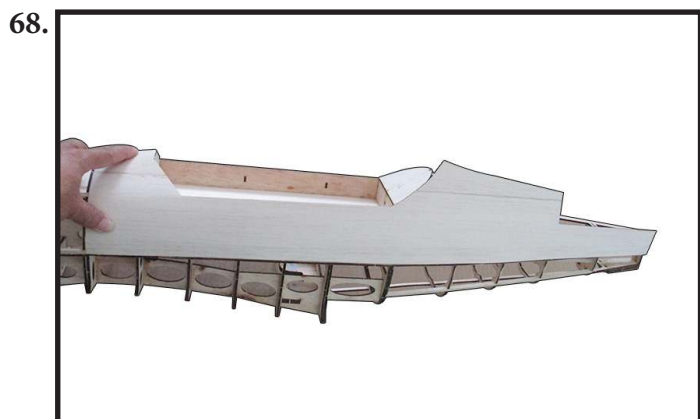

Weld together two difference pieces SH4 become a sheet (left and right) by CA glue as photo shown. (photo 69,70).

Put the sheet SH5 at area of fuselage as photo shown (photo 72).

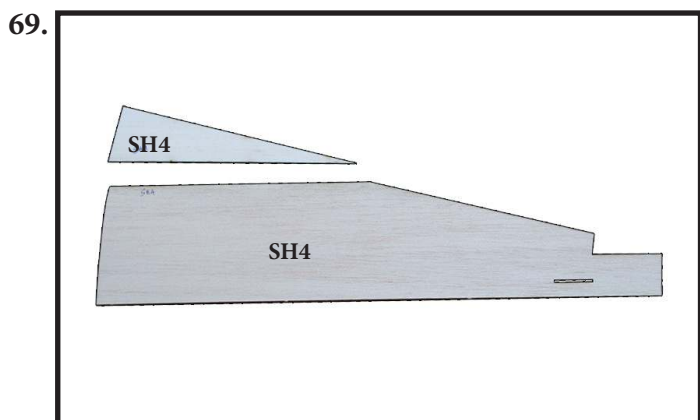

Bend the balsa sheet SH5 go to the curve bottom area and toward area. Then, add CA glue and use the finger at this place until the glue dries as photo shown.

Do the same for the other half of bottom area and toward area, so that the balsa sheet keep fixed fuselage.

Then, add a little epoxy glue inside at intersect place of all ribs and sheet.

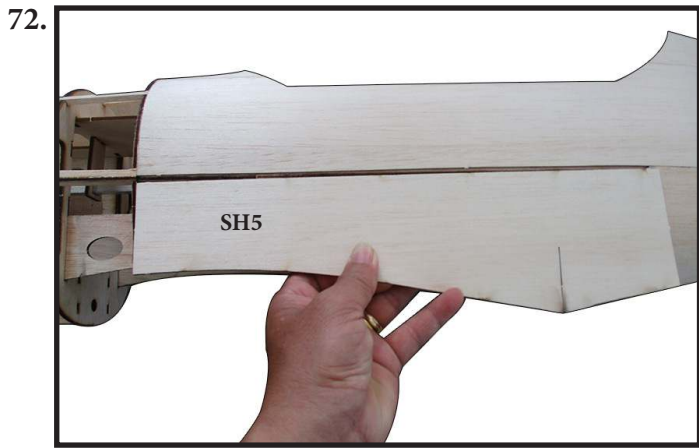

Put the sheet SH6 at area of fuselage as photo shown (photo 75).

Bend the balsa sheet SH6 go to the curve toward area. Then, add CA glue and use the finger at this place until the glue dries as photo shown.

Do the same for the other half of toward area, so that the balsa sheet keep fixed fuselage.

Then, add a little epoxy glue inside at intersect place of all ribs and sheet.

Weld together three difference pieces SH6 become a sheet (left and right) by CA glue as photo shown. (photo 73,74).

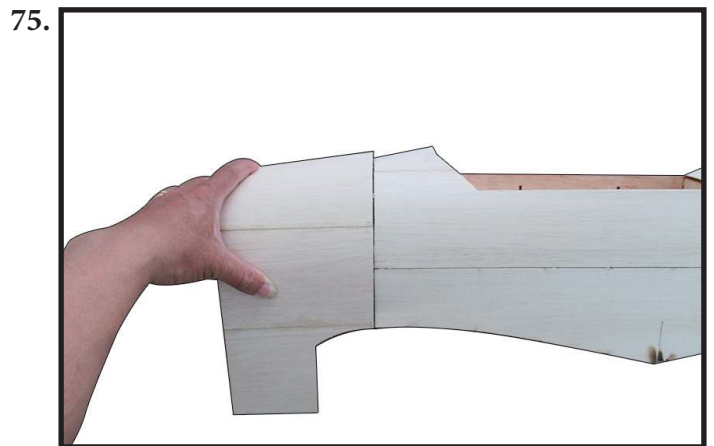
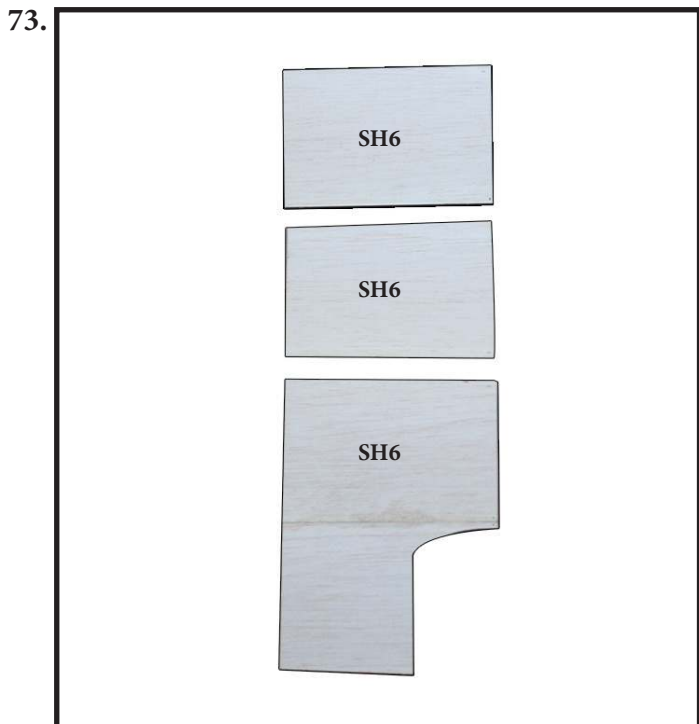

Cover sheet SH7 (left and right) as (photo 76).

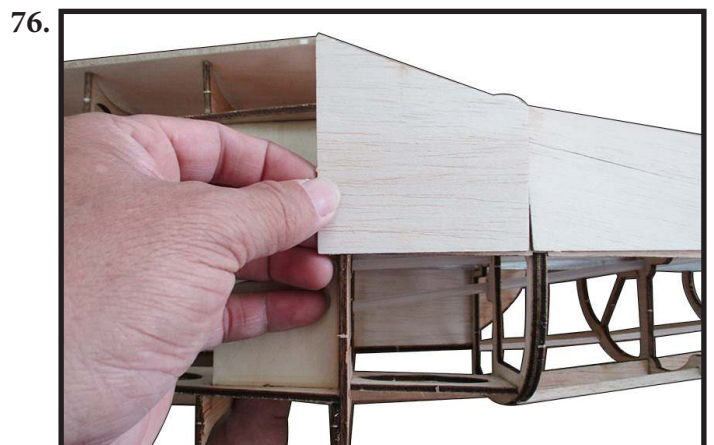
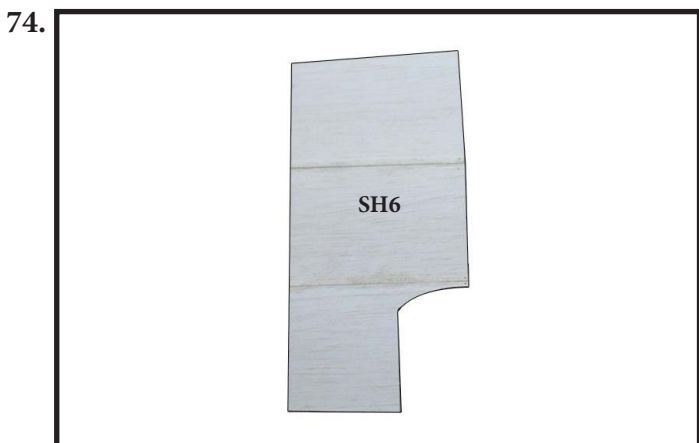

Cut down the excess part of sheet. Then, sanding a round fuselage for smooth and seamless.

# THE WING

## \* Landing gear mount.

Locate and apply CW19A (2pcs) to CW19 by CA as photo shown (photo 1,2).

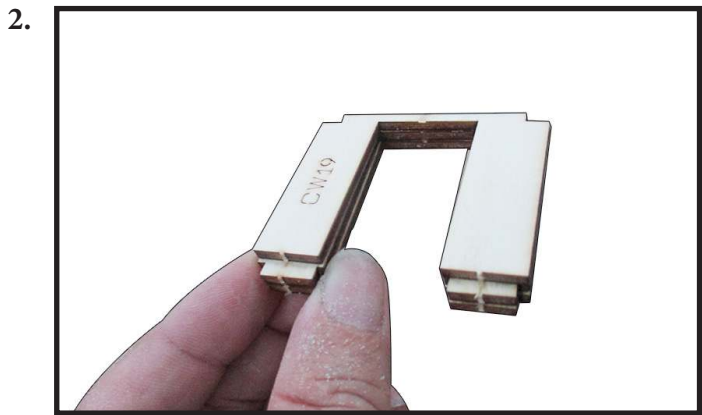
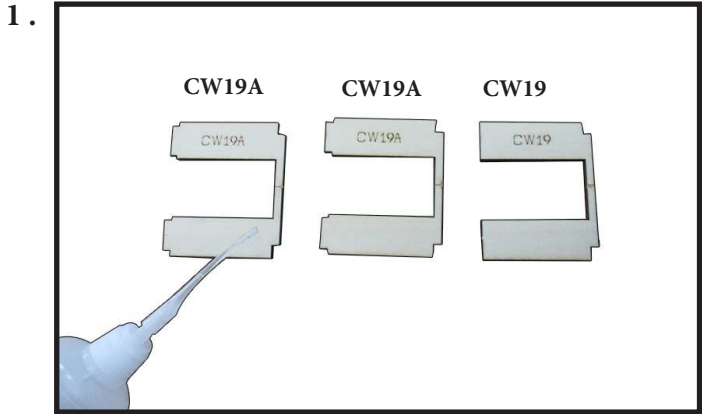

Locate and apply CW2A to CW2; CW3A to CW3 by epoxy as photo shown (photo 3,4). **NOTE: Apply to assemble ribs of wing left and ribs of wing right are symmetrical to each other.**

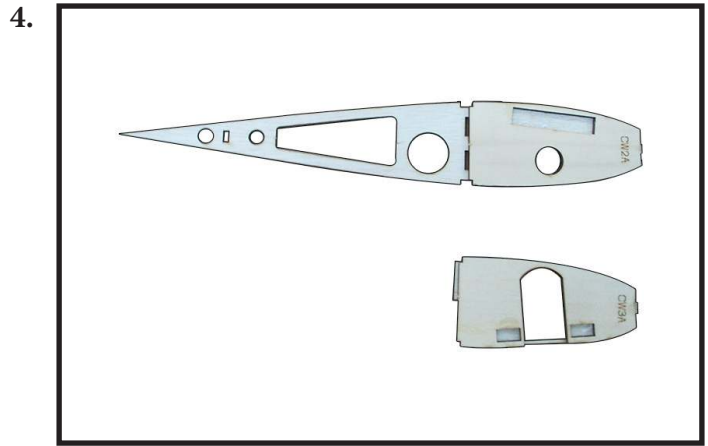
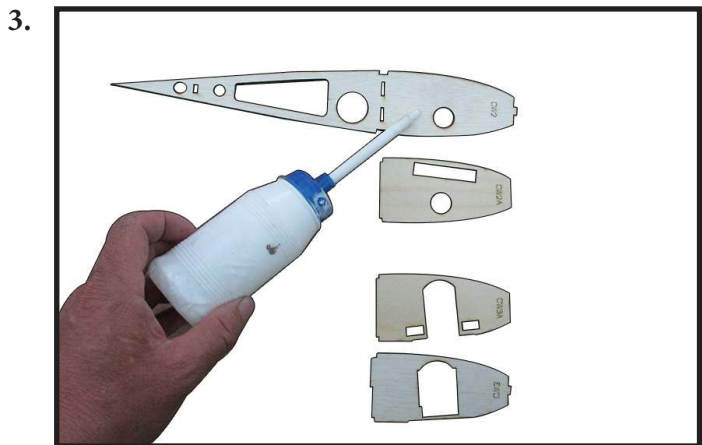

Finish as (photo 5).

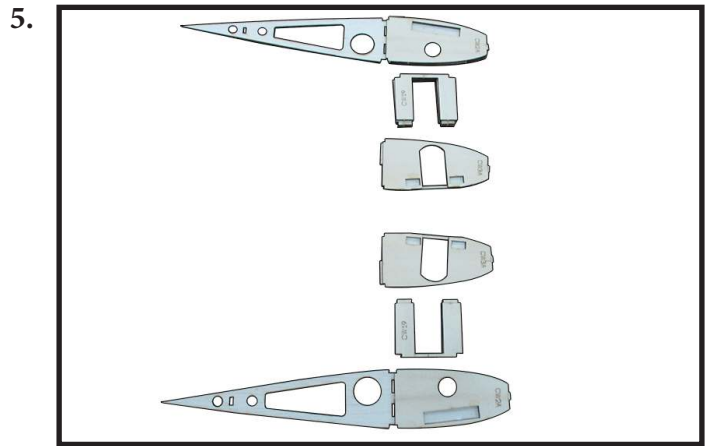

Pick some parts as shown (photo 6) (CW1-CW22) so that prepare for assemble the center wing.

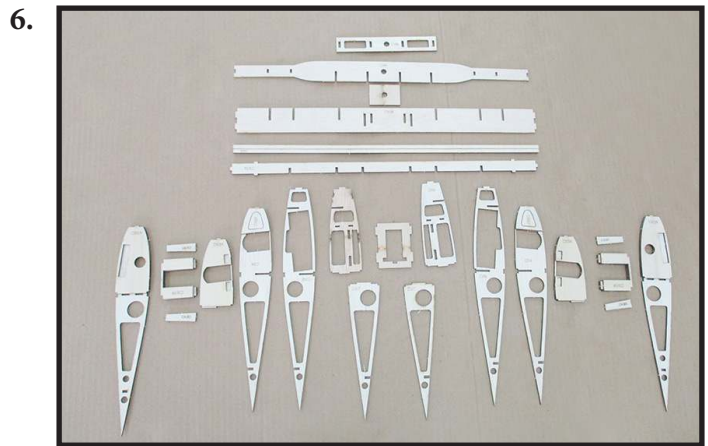

Locate and assemble the rib, one after another in order CW1-CW7 (two sides) to CW12. Then, assemble CW22 at between as (photo 7,8).

7.

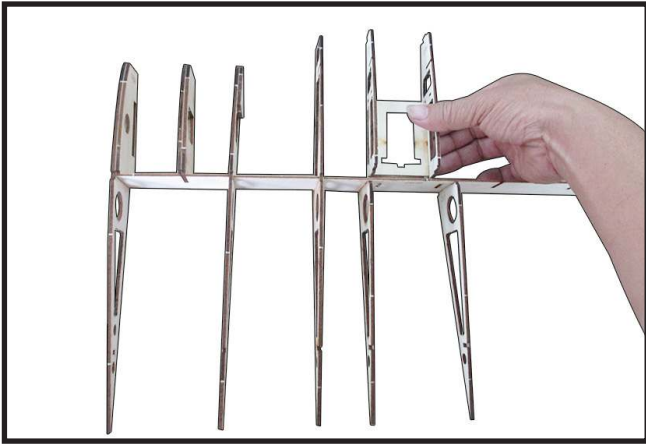

10.



8.

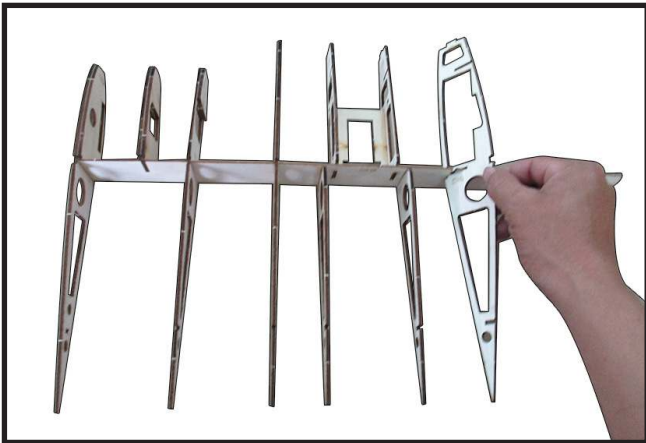

Locate and assemble CW8 (leading edge) as (photo 11).

11.

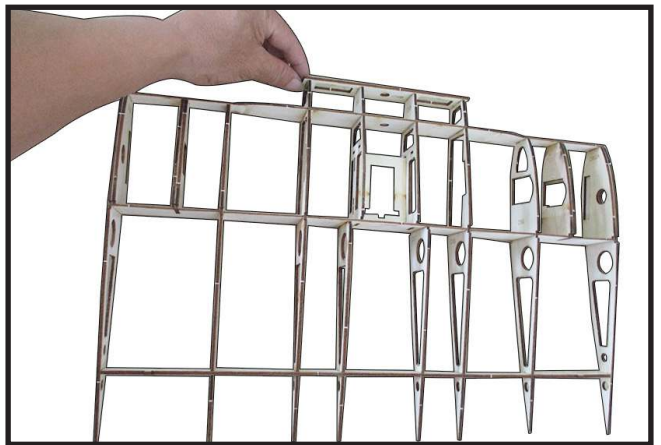

Locate and assemble CW14 (trailing edge) as (photo 9).

9.

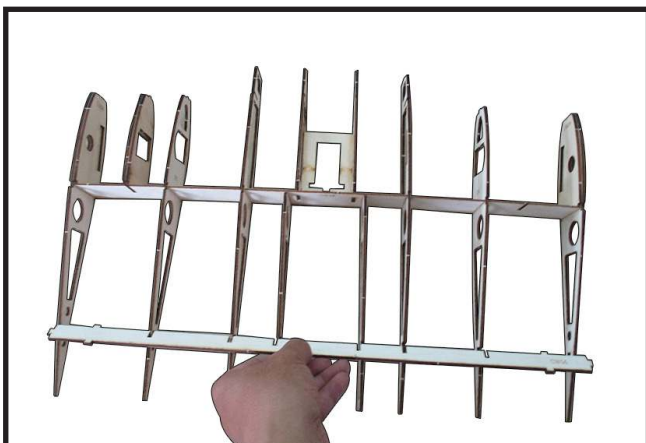

Locate and assemble CW10 (reinforce leading edge) as (photo 12).

12.

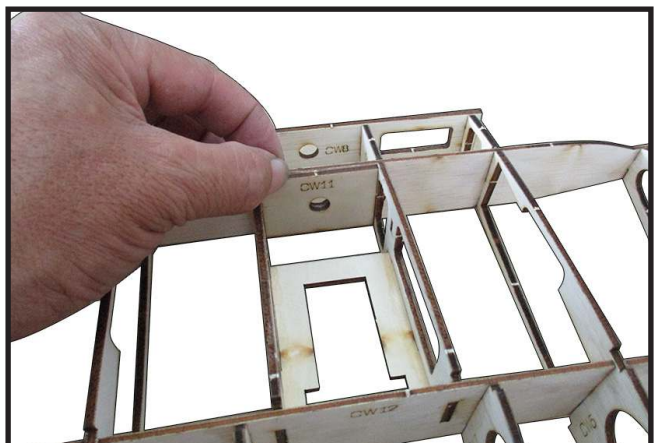

Locate and assemble CW9 (leading edge) as (photo 10).

Locate and assemble CW13 (cap strips) at top wing and bottom wing as (photo 13).

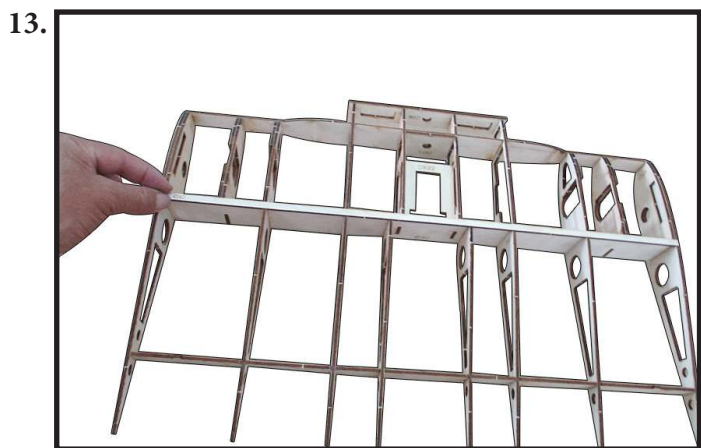

Locate and assemble CW19 (gear mount) by epoxy glue as (photo 14,15).

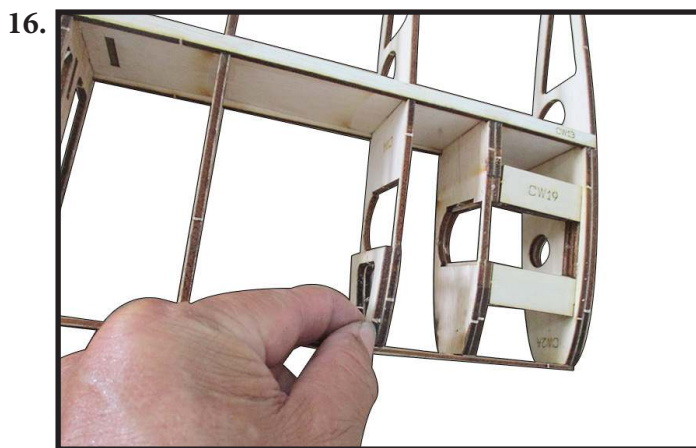

Locate and apply CW11 (reinforce for servo mount) by epoxy glue as (photo 17,18).

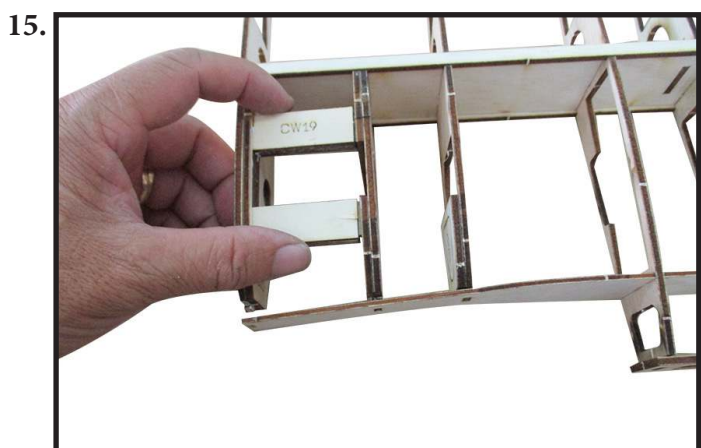
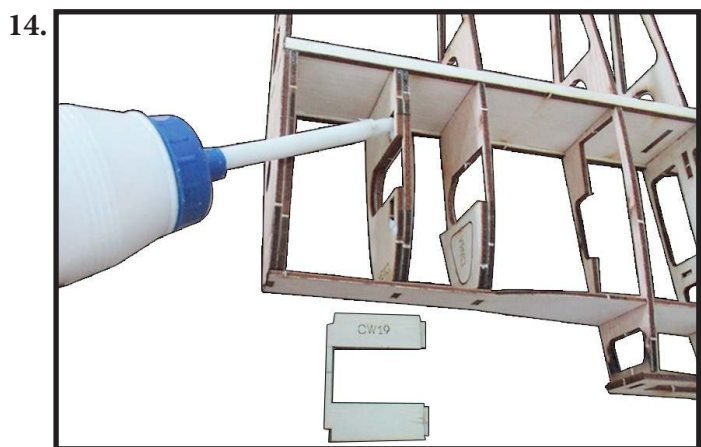

Locate and apply CW4A (reinforce for gear area) by epoxy glue as (photo 16).

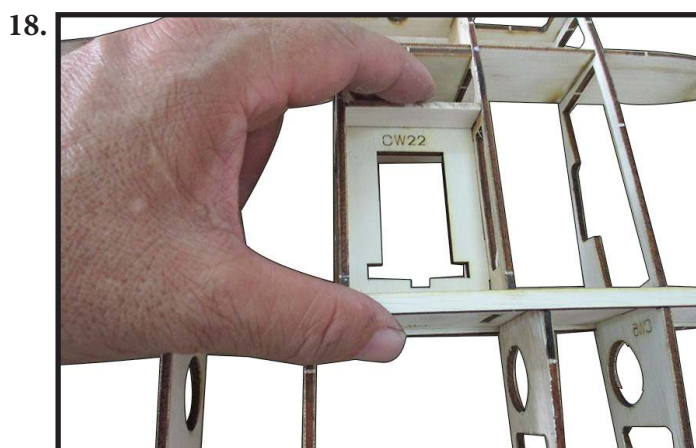
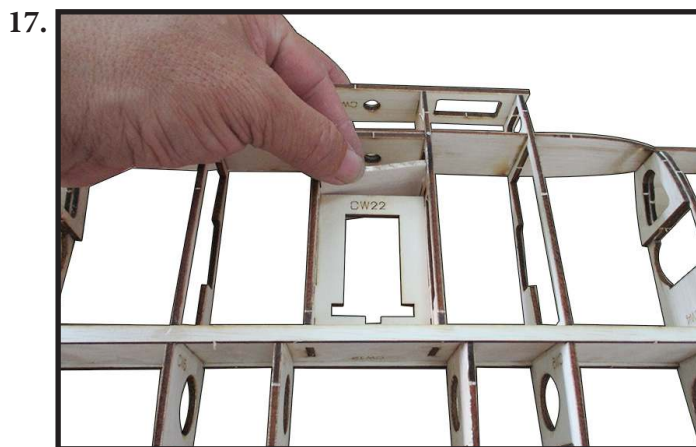

Locate and apply CW20 (reinforce for gear mount) by epoxy glue as (photo 19,20).

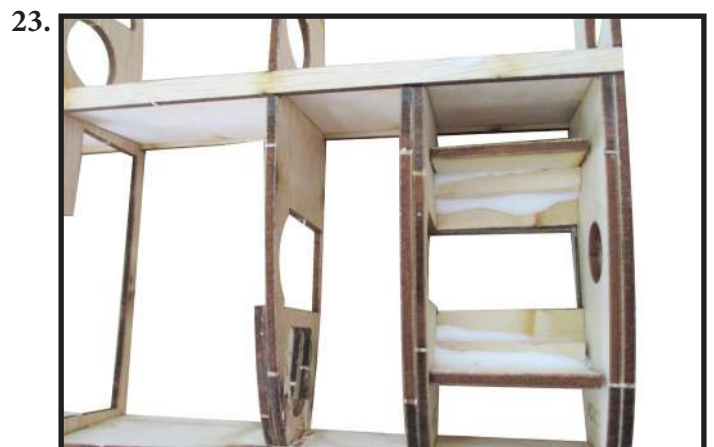
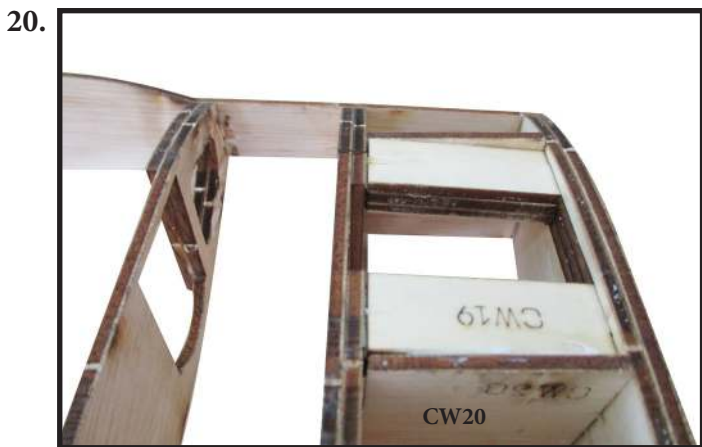
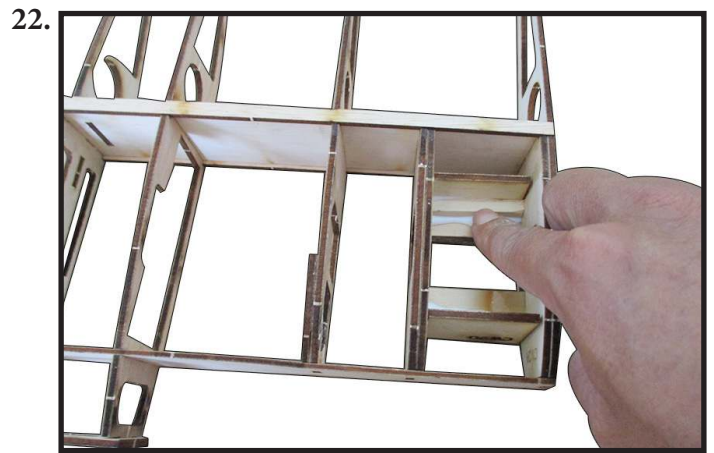

Locate and apply the square stock (reinforce for gear mount) at inside angle of CW19 and CW20 by epoxy glue. Then, add a little epoxy glue as (photo 21,22,23).

Locate and apply CW8A 8mm balsa (reinforce for leading edge) by epoxy glue as (photo 24).

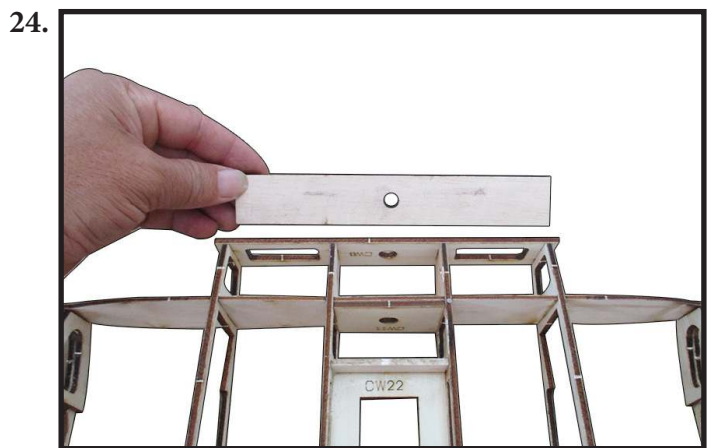

Apply CW23 8mm balsa (4pcs) (left and right) by epoxy glue as (photo 25).

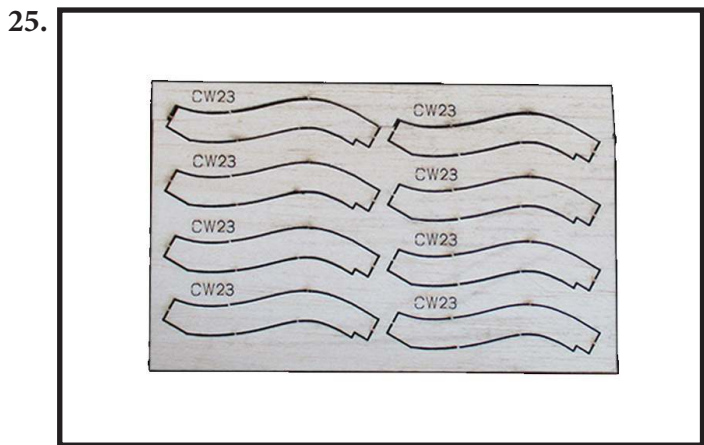

Locate and assemble CW23 balsa (4pcs) (left and right) by epoxy glue as (photo 26).

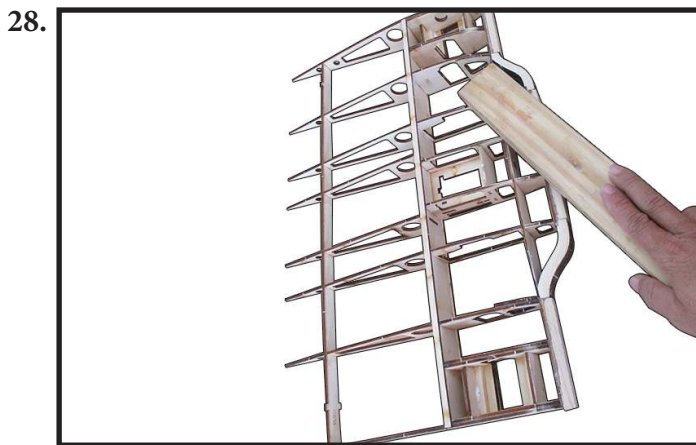

Locate and assemble wing tube. Light sanding the wing tube to it can through to holes easily as photo shown (photo 29).



Cut off excess part of balsa and sanding for leading edge look like seamless. (Photo 27,28).

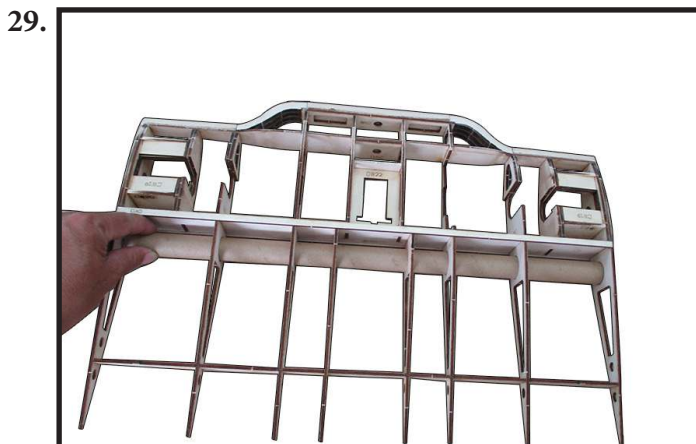

Locate and assemble the hard wood (the mount of wing bolt down) as (photo 30).

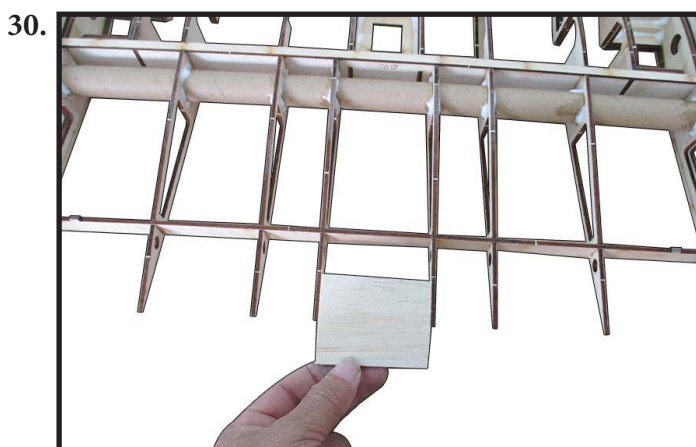
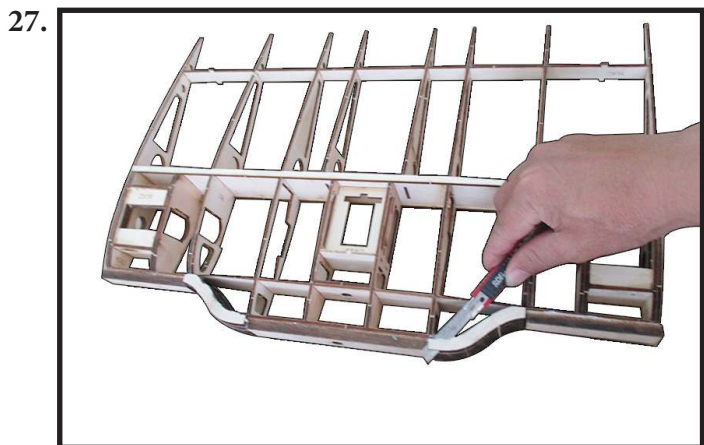

\* Finishing The Outer Wing Panels.



Weld 4 parts of CW16, together to become a sheet . Do like this for 4 parts of CW17 (Photo 31,32).

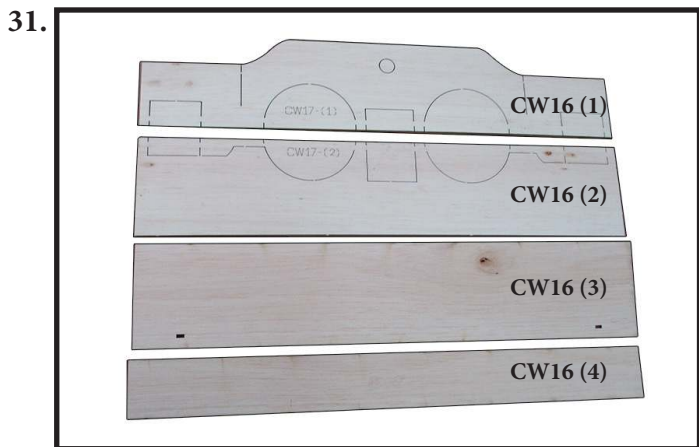

Locate and assemble CW15 as (photo 35,36).

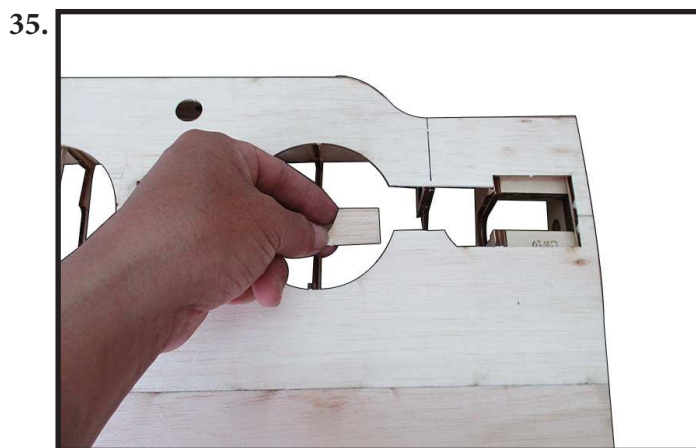
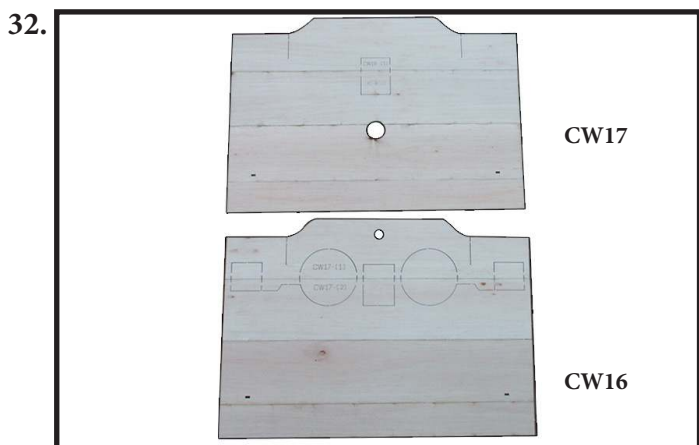

Cover sheet CW16 to wing at bottom side. Then, CW17 to wing at top side as photo 33,34).

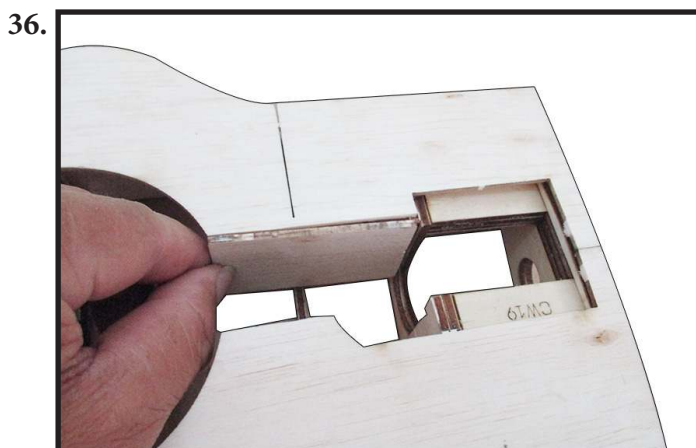

Pick some parts as shown W1-W21 so that prepare for assemble the side wing. (Photo 37).

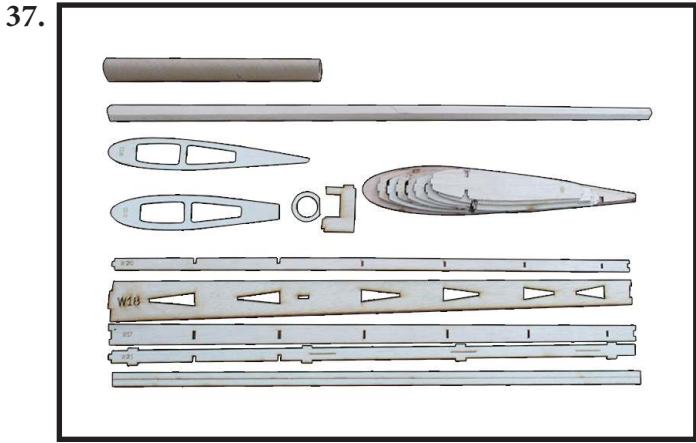

Locate and assemble the rib, one after another in order W2-W9 (two side wing) to W18. as (photo 38,39,40).

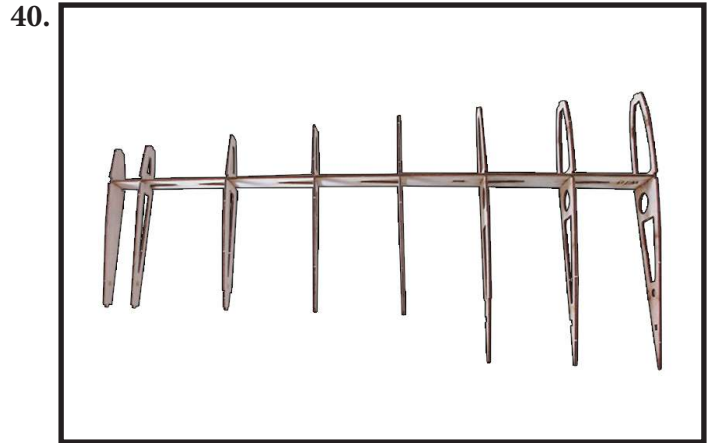

Prepare leading edge W17 and trailing edge W20, W21 and cap strip W19 as (photo 41).

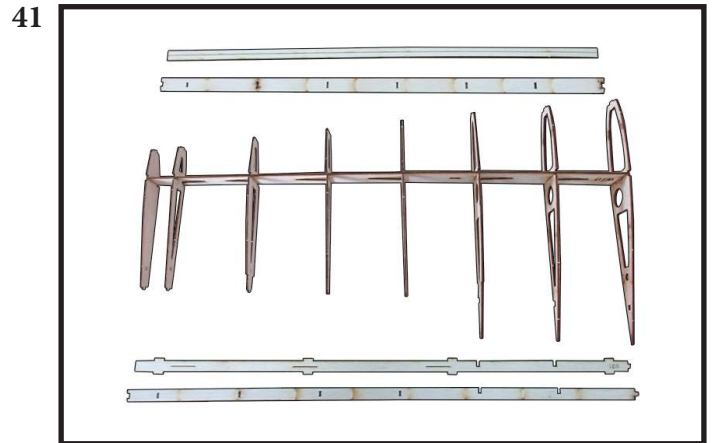
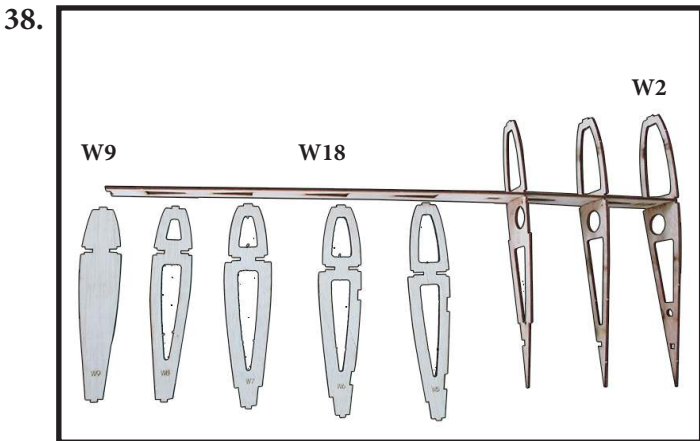

Locate and assemble leading edge W17. **Note: the small point is bottom side. Correct assembly to create a dihedral angle for the wing. (Photo 42).**

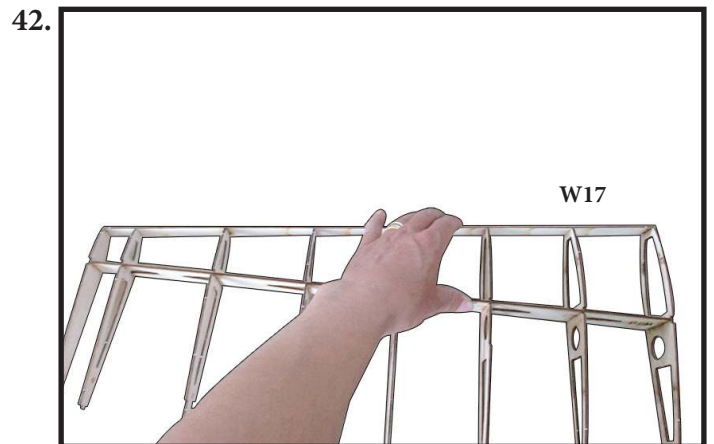
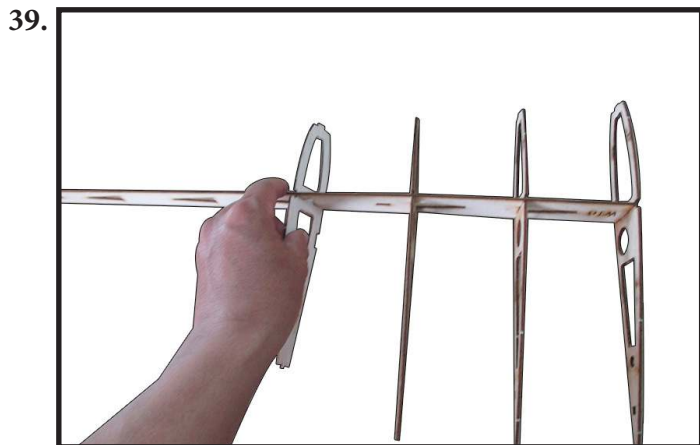

Apply trailing edge W20 to W21 as (photo 43,44).

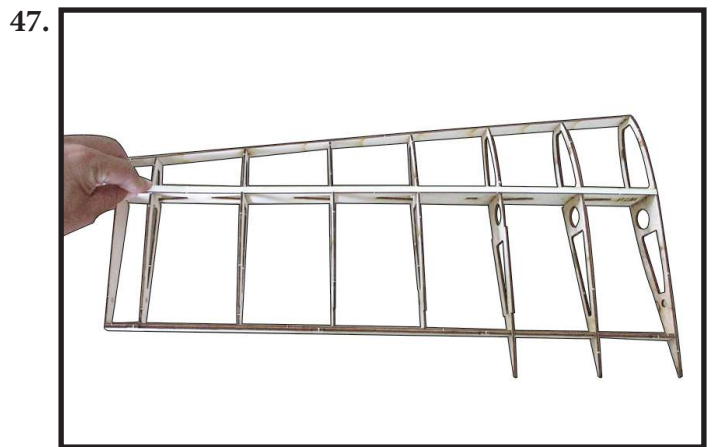
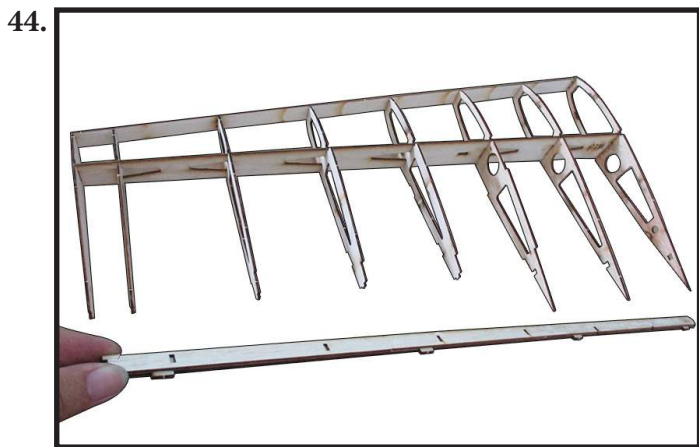
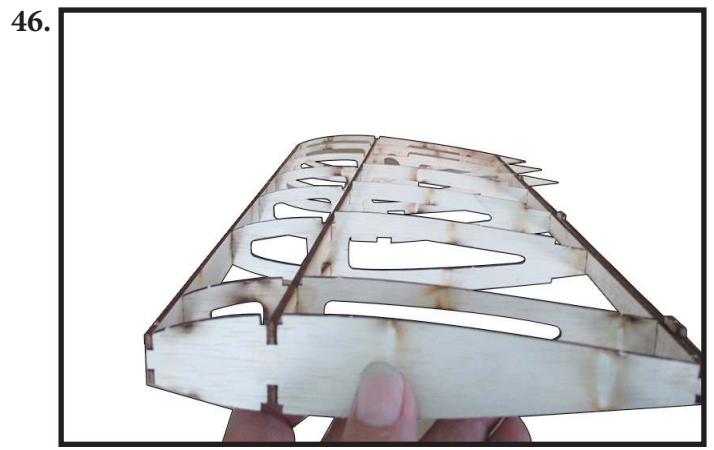
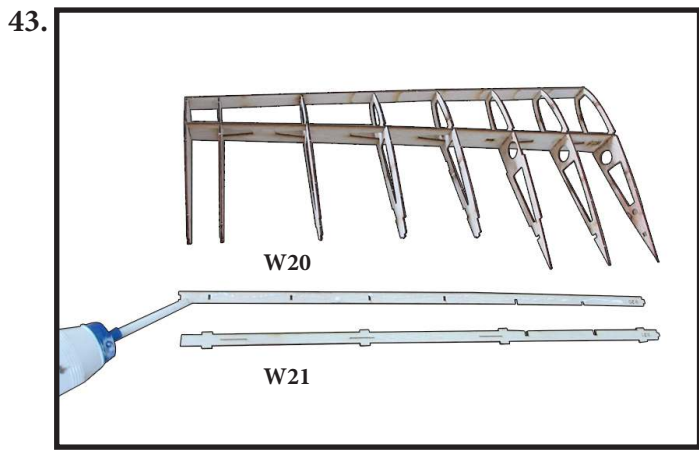

Locate and assemble trailing edge W20, W21.  
(Photo 45).

Locate and assemble the lock of wing tube W29  
(Photo 48).

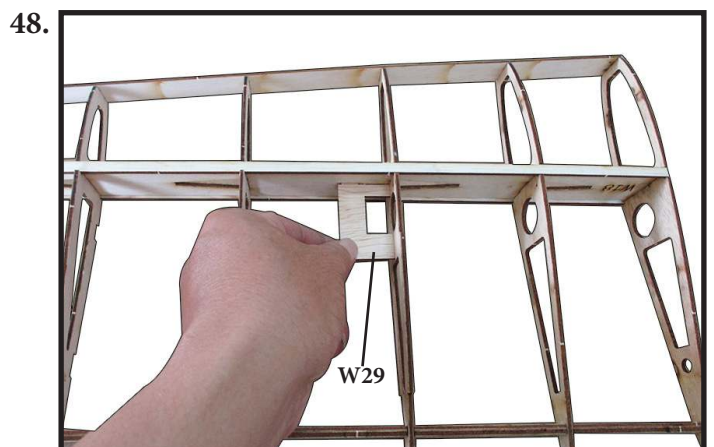
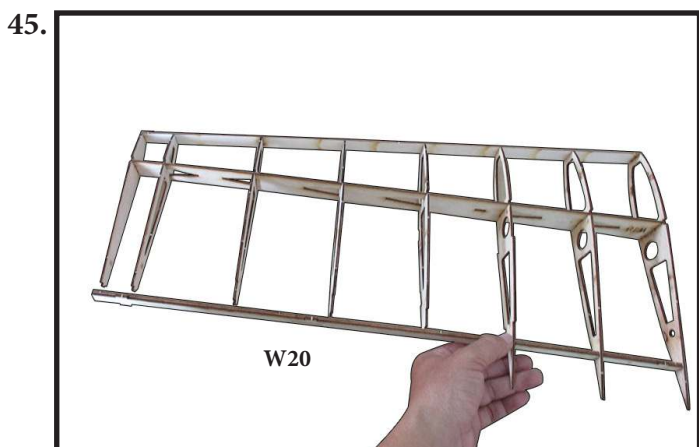

Locate and assemble cap strip W19 (top and  
bottom). (Photo 46,47).

Locate and assemble W30 (the ring washer of  
wing tube) to fix the tube. Then, add epoxy glue  
at intersect place of the tube with the rib. (Photo  
49,50).

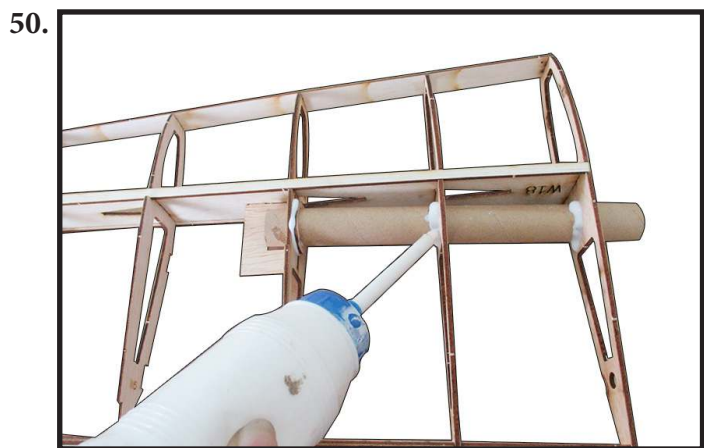
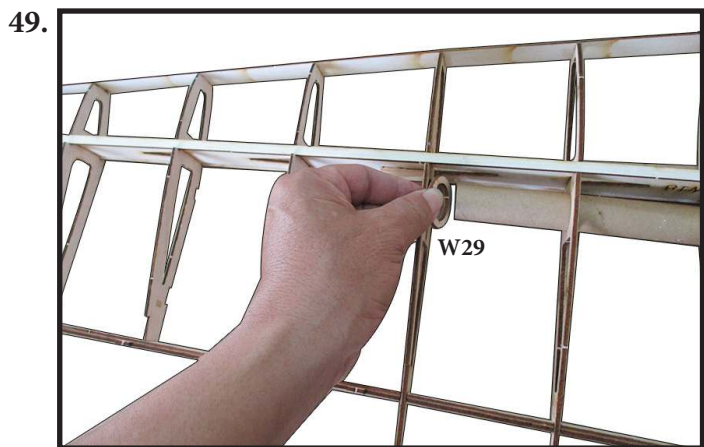

Light sanding until the balsa strip look like seamless W17. (Photo 53).

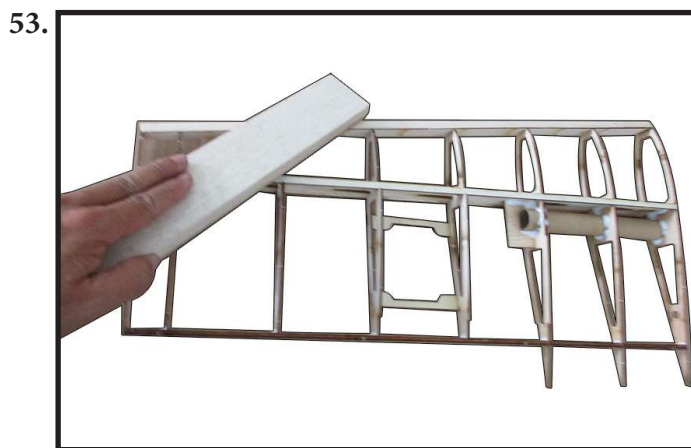

Locate and assemble W12, W13 (servo mount) as (photo 51).

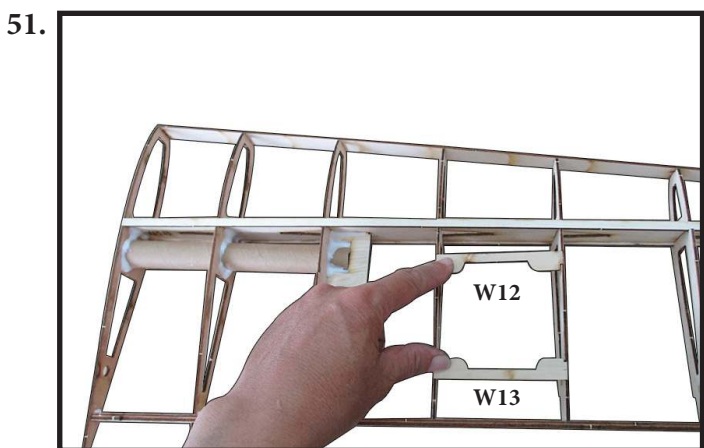

Try to test center wing and side wing fit together by use wing tube to join the two panels rib's frame. (Photo 54,55).

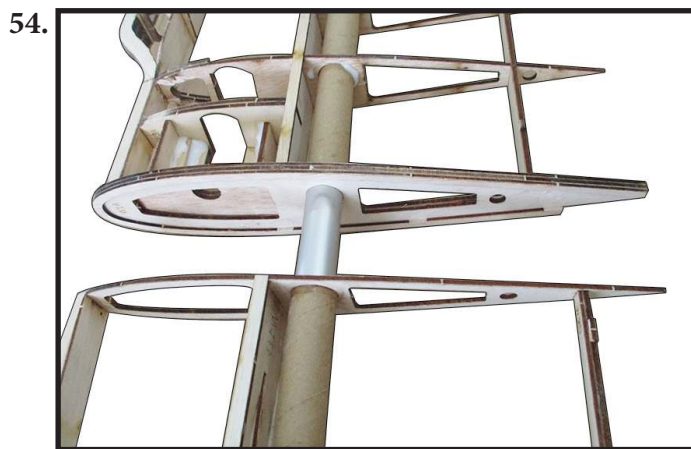

Apply the balsa strip to leading edge W17 as (photo 52).

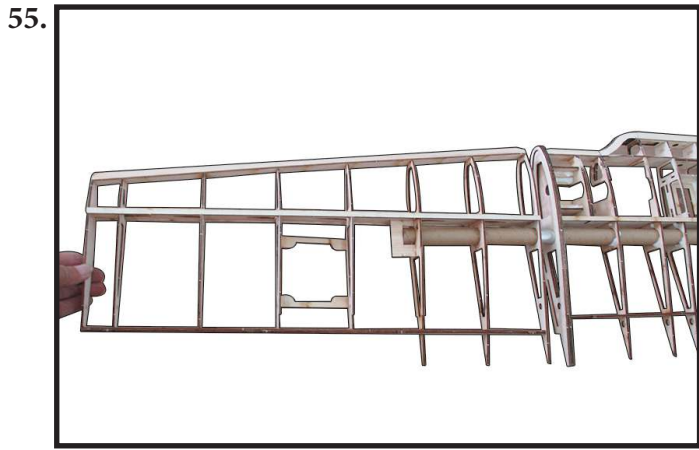

**\* Finishing The Outer Wing Panels.**

Locate and cover sheet W27 at top side wing as (photo 56).

Weld two parts of sheet W25 together to become one. Then, cover to bottom side at servo hatch's place as (photo 59,60).

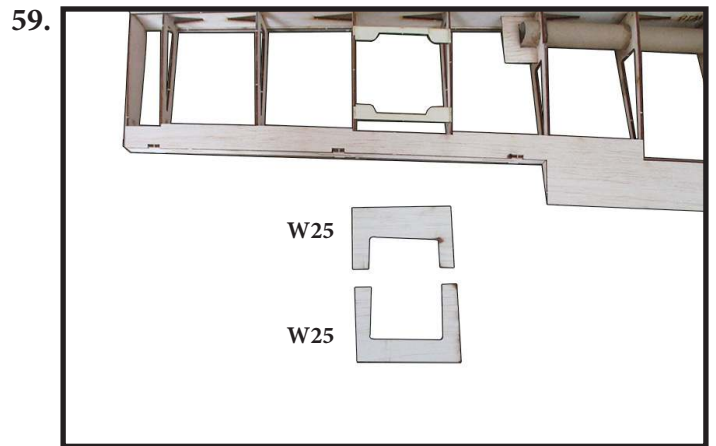
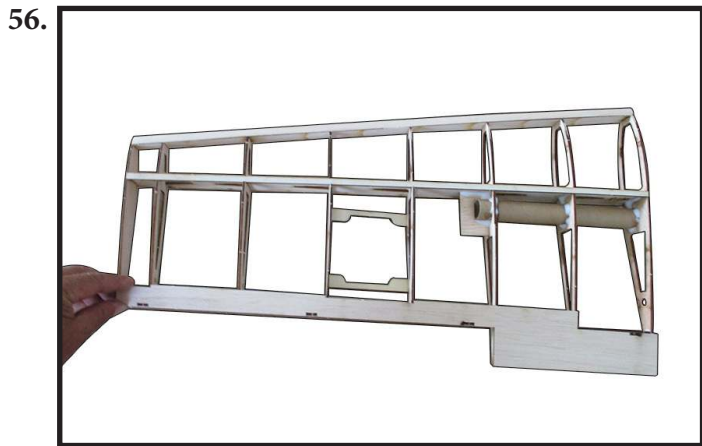

Weld two parts of sheet W22 together to become one. Then, cover to top side as (photo 57,58).

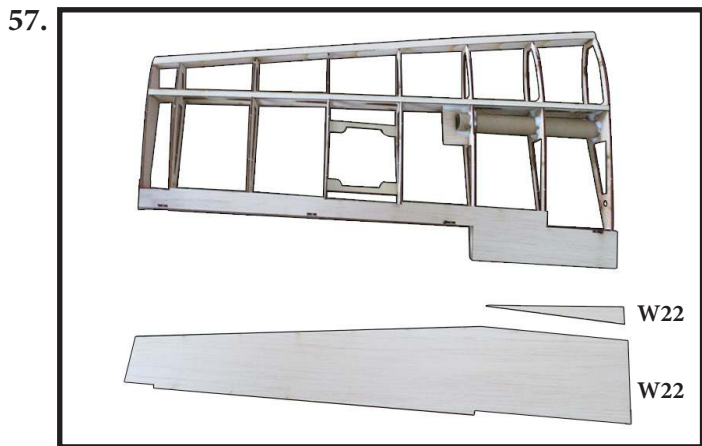
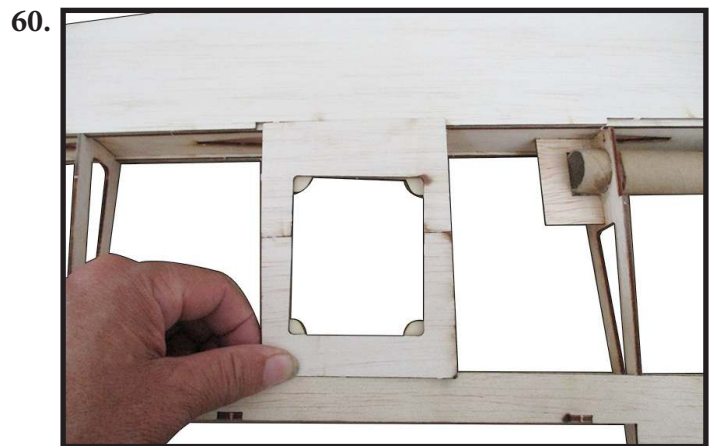

Weld two parts of sheet W24 together to become one. Then, cover to top and bottom side as (photo 61,62).

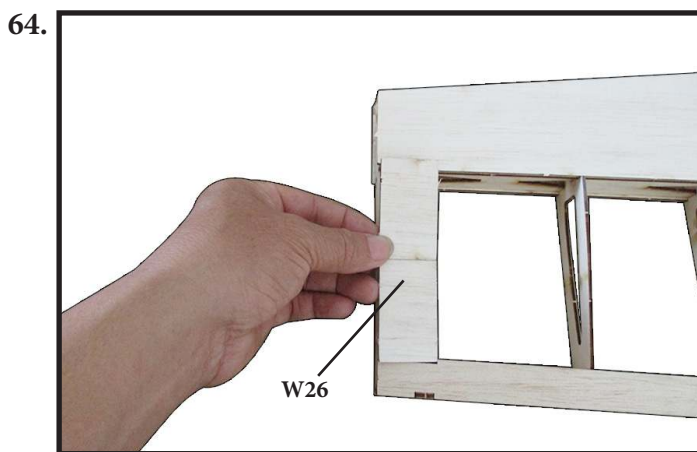
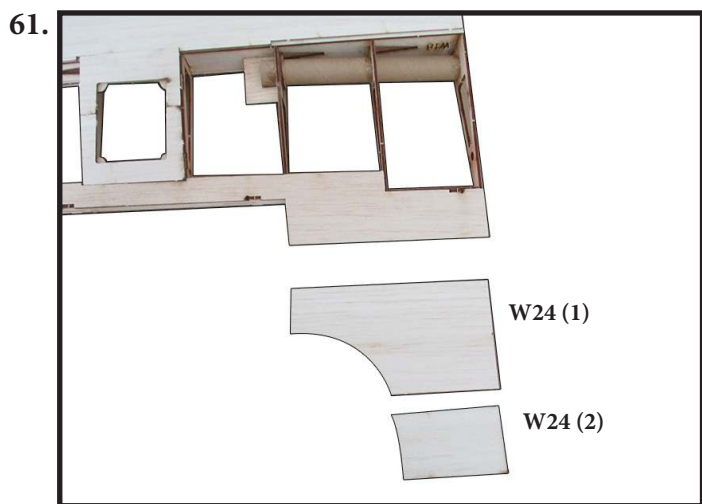

Sanding at the root for flat and remove the excess part of sheet. (Photo 65).



Weld two parts of sheet W26 together to become one. Then, cover to top and bottom side as (photo 63,64).

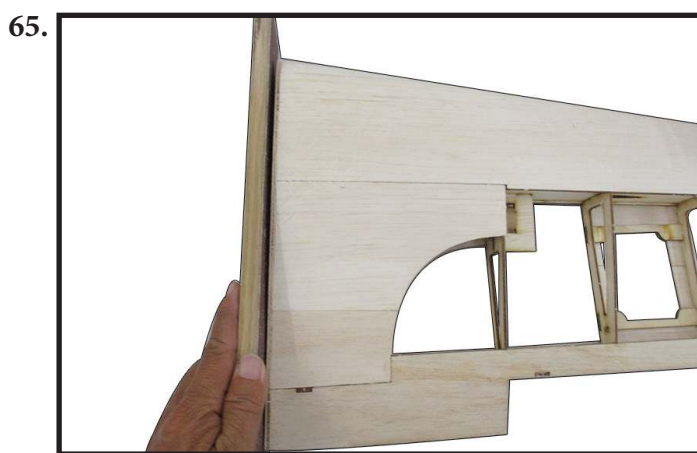

Locate and apply W1 at the root and W10 at the tip. (Photo 66,67).

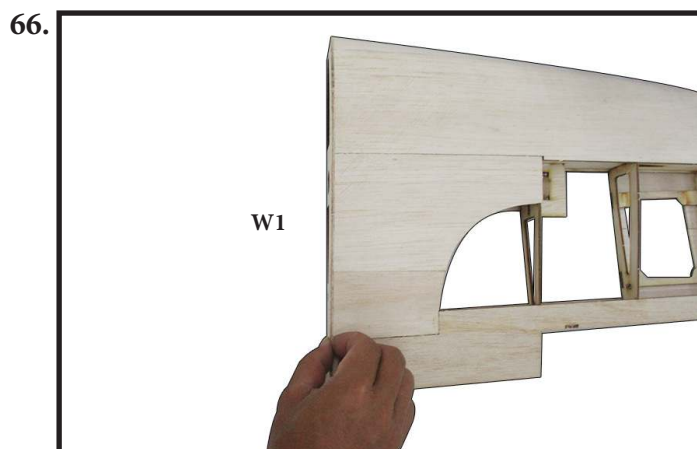
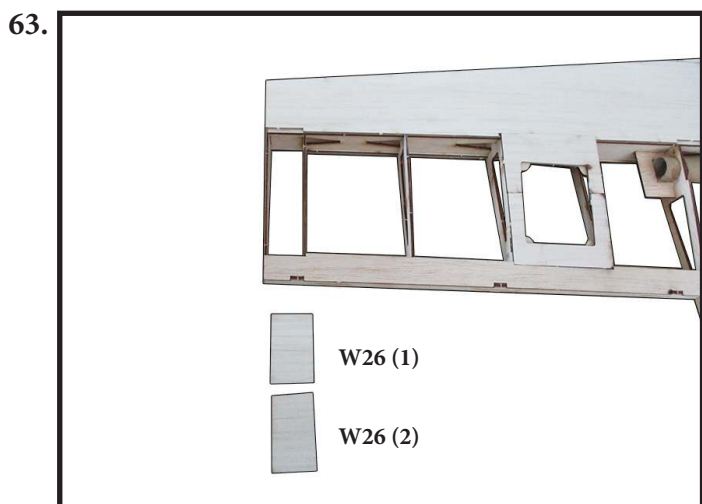

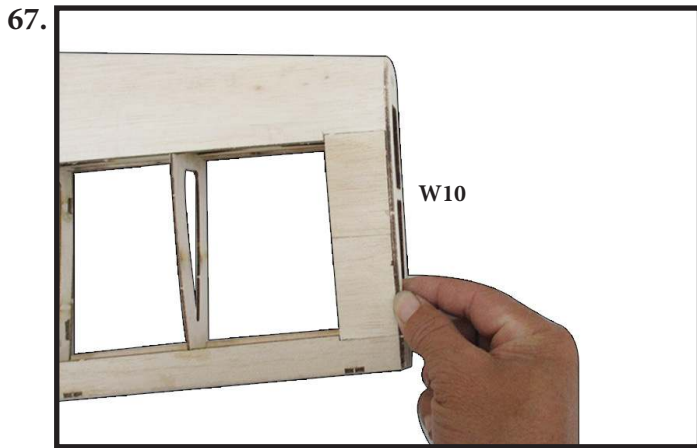

Sanding a round the wing for smooth and rounded leading edge. (Photo 68).

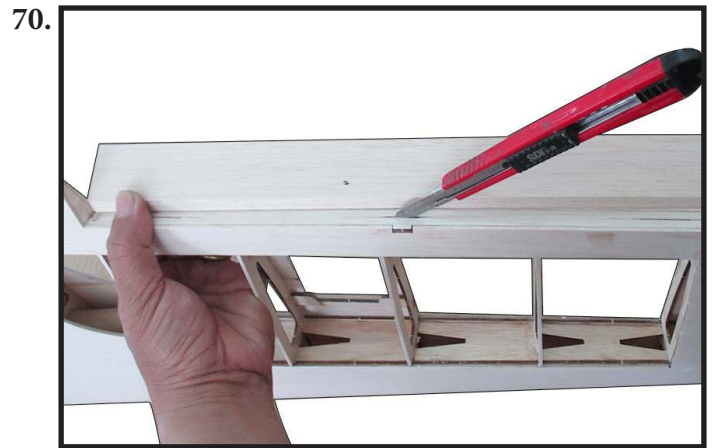

Locate and assemble W11 (tip) to the plastic tip cover by CA glue as (photo 71,72).

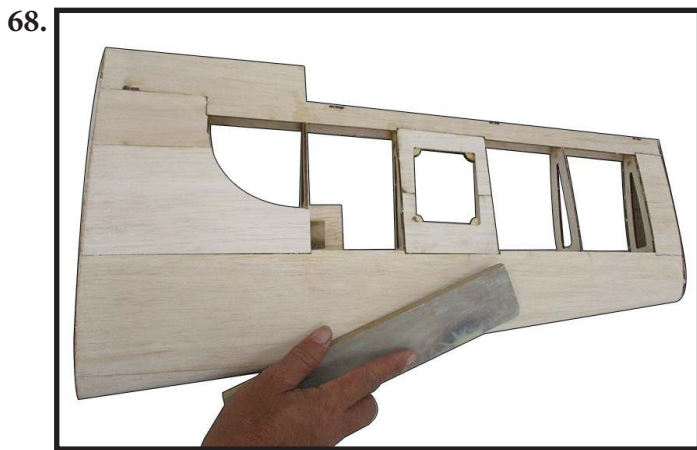

Attach the aileron ( balsa stock) to wing by CA hinge. (Photo 69).

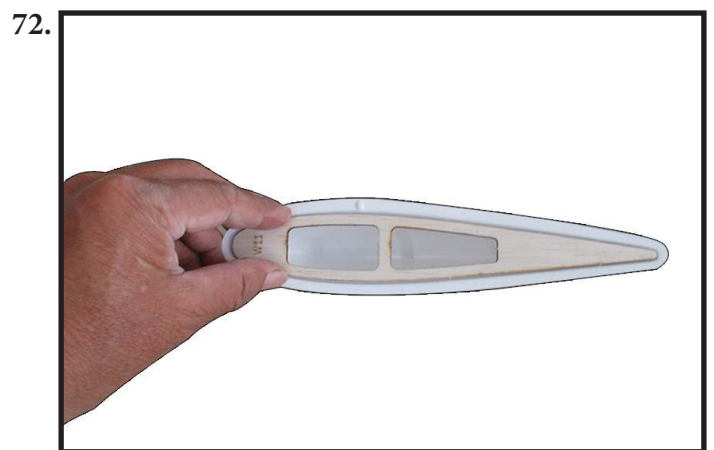
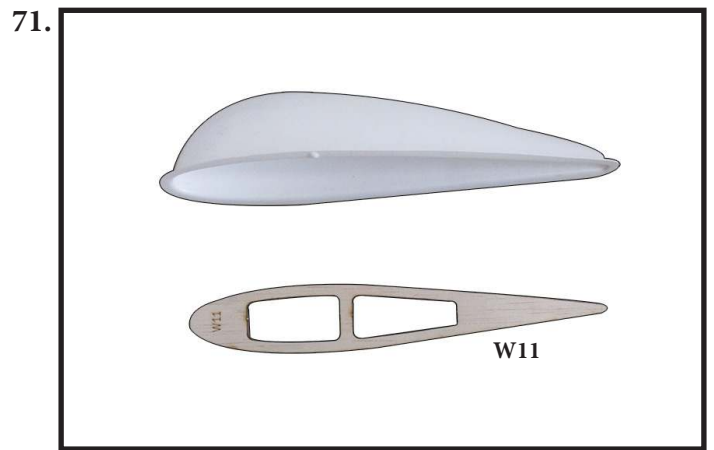

Cut down the excess plastic parts and sanding for flat the tip as (photo 73).

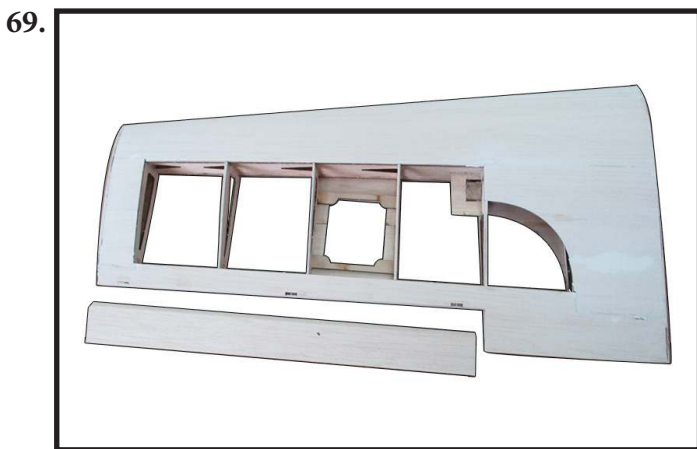

Locate and sawn the slot for hinge. **Note: cut off the slot fit so that avoid so wide cause CA hinge will fall out.** (Photo 70).

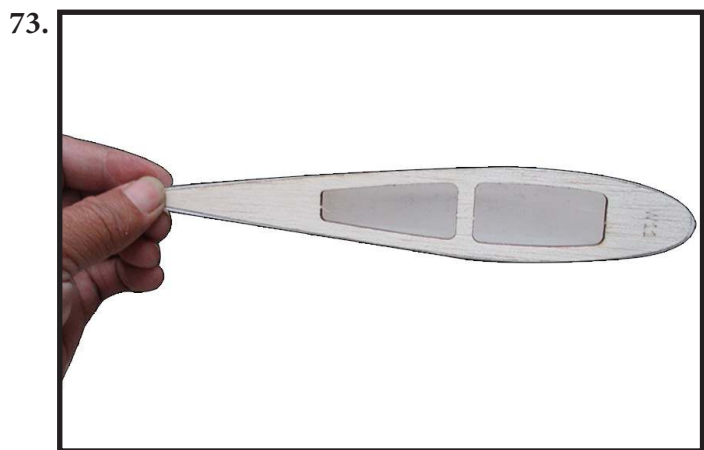

Cut down the excess plastic parts and sanding for flat the tip as (photo 74).

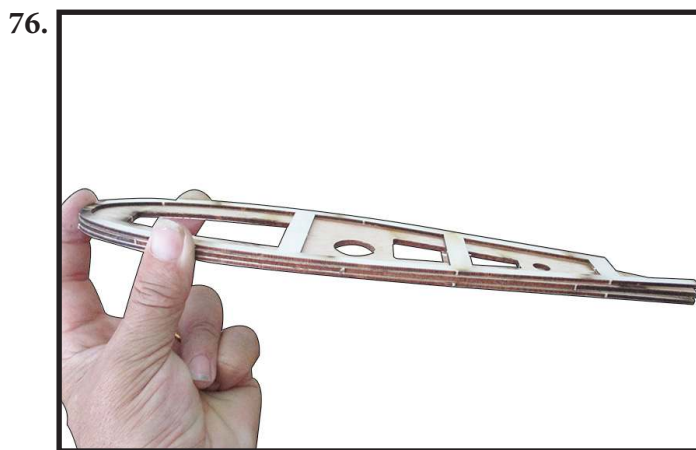

Remove the vertical wood excess by blade as (photo 77,78).

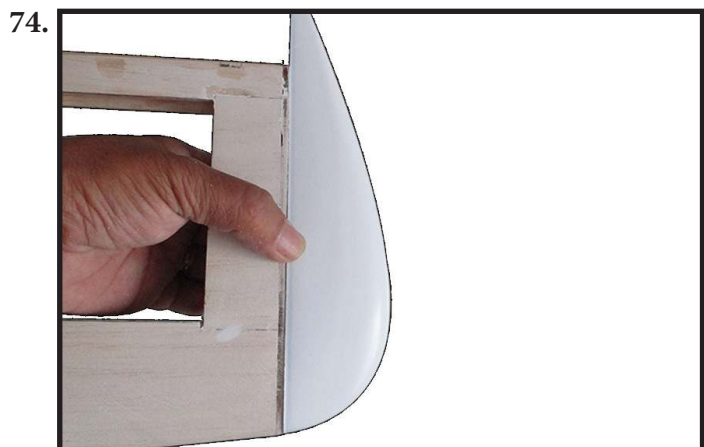

Locate and apply three ribs together, one after another one W1B-W1A-W1B as (photo 75,76).

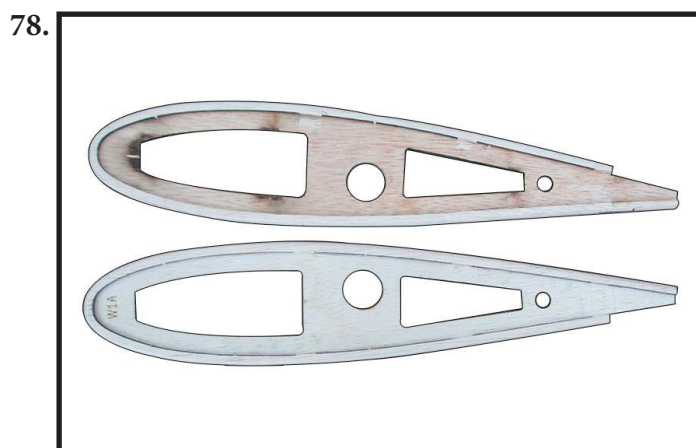
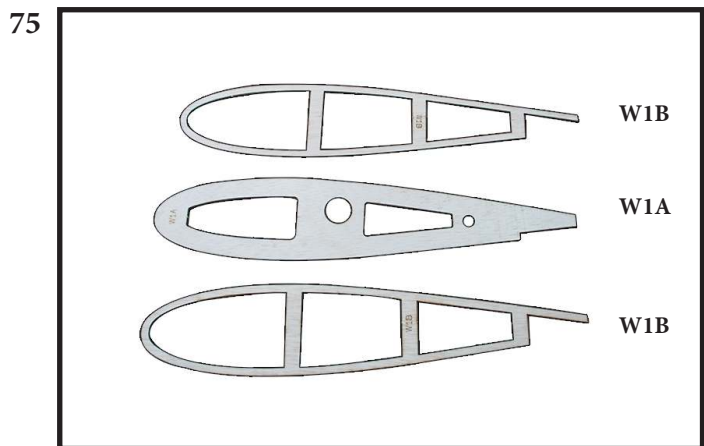
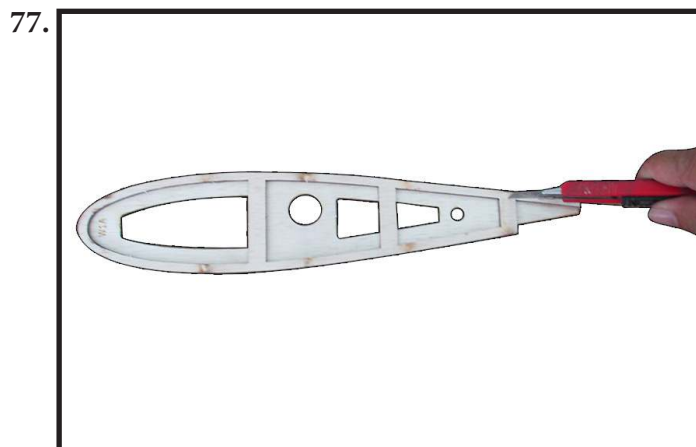

Sanding rounded the rib as (photo 79).





Locate and assemble the rib between the wing center and wing side (left and right) as (photo 80).

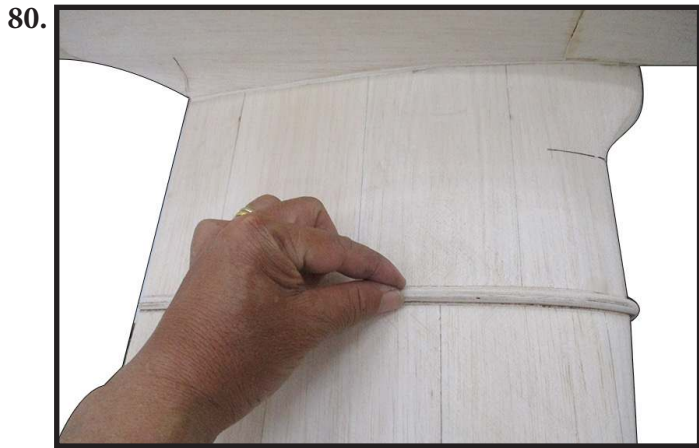

Assemble the servo mount hatch. (Photo 81,82, 83,84).

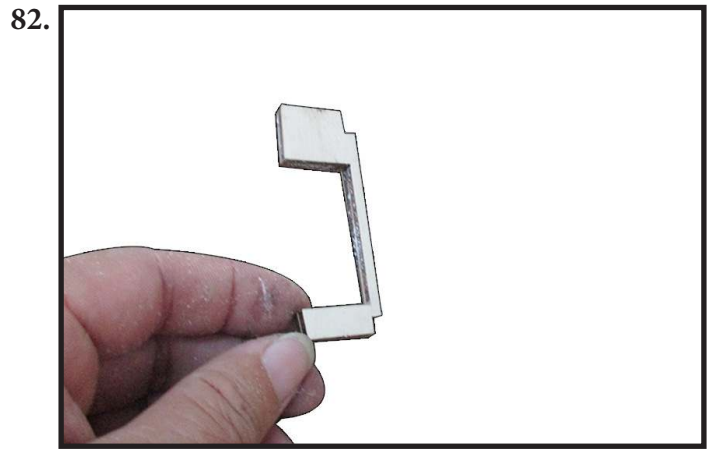
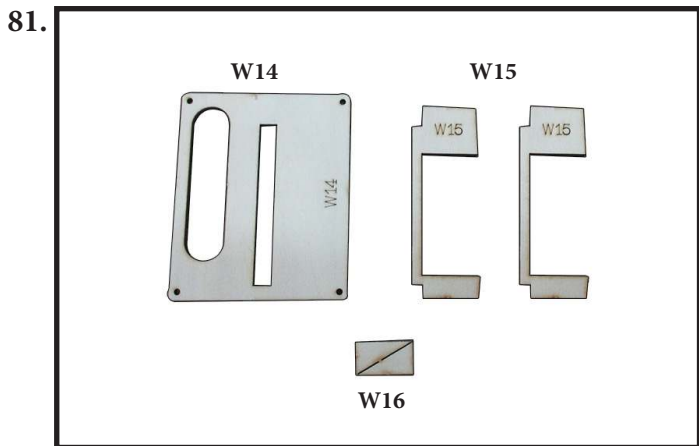

**THE STABILIZER AND ELEVATOR**

Prepare for assemble the Stabilizer and Elevator.

Balsa 8mmx10mm x50mm spars.

Balsa 8mmx10mm x230mm spars.

Balsa 8mmx10mm x230mm spars.

The laser cut special parts are available from code ST4 – ST8.

Locate and assemble the Stabilizer as the plan. Step by step do it one after another in order 1-10. Use the nail to plug in keep the rib on the paper plan and add CA glue. (Photo 1).

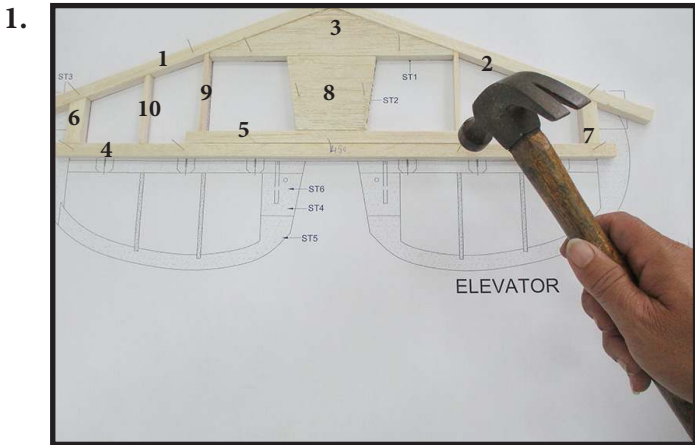

Cut off the excess balsa wood part and sanding smooth and flat the edge (Photo 2).

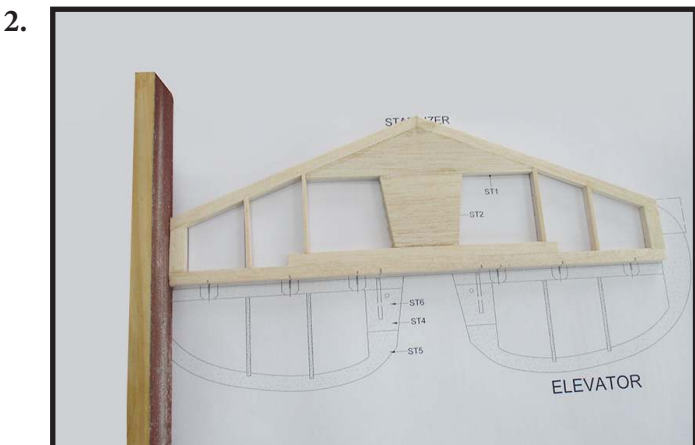

Locate and assemble ST3 (left and right) as (photo 3).

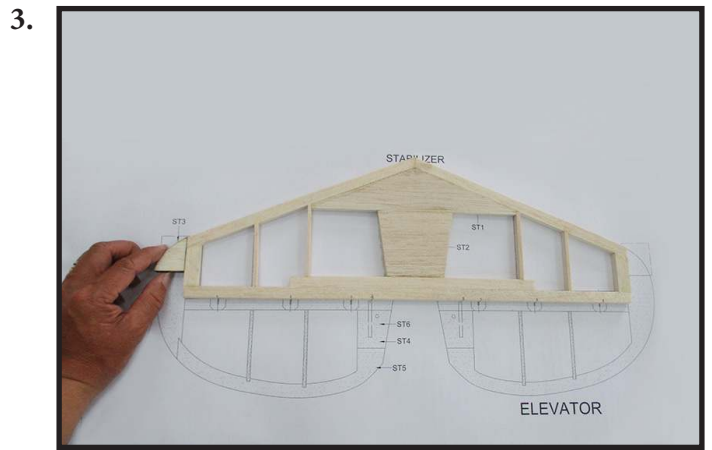

Take up the elevator part ST5 – ST8 as (photo 4).

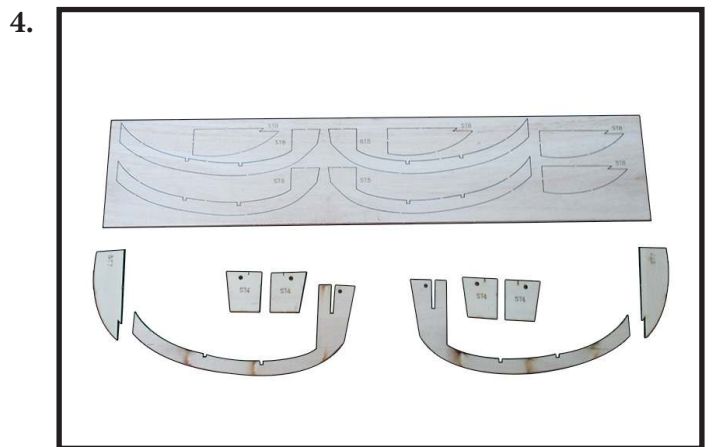

Locate and assemble the elevator (left and right). (photo 5,6,7,8).

ST6 between two pieces ST4;

ST6 between two pieces ST5;

ST7 between two pieces ST8;

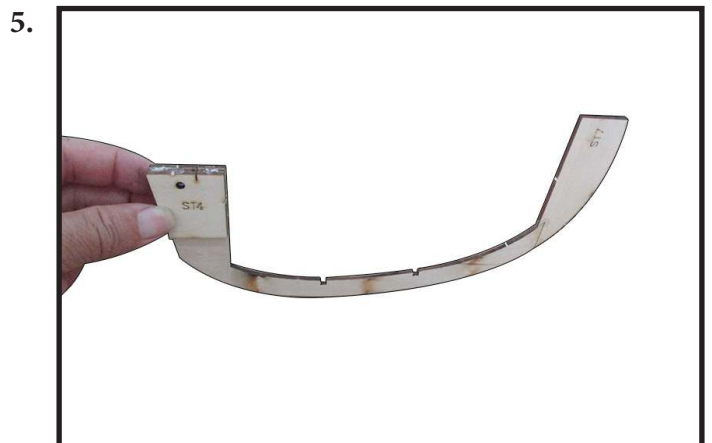

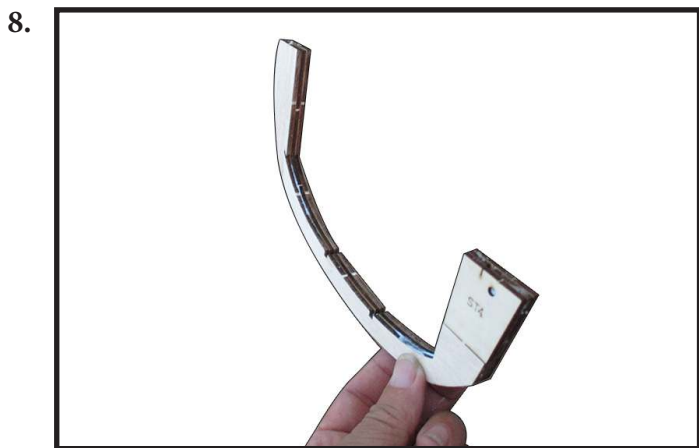
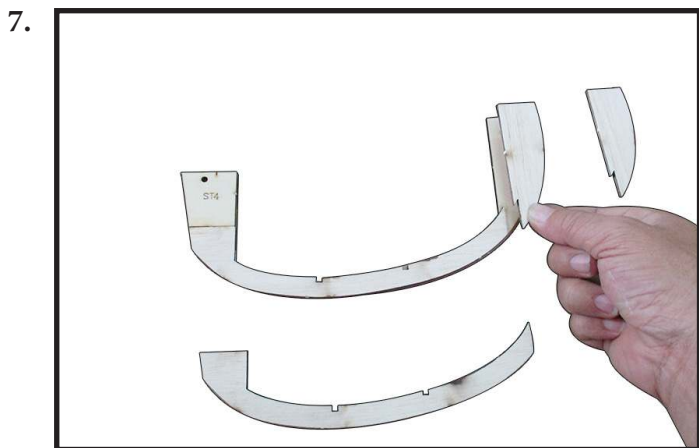
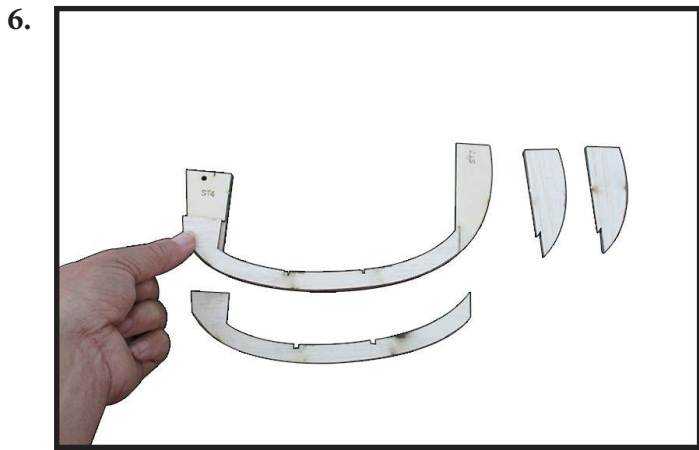

Locate and assemble the Elevator as the plan. Step by step do it one after another in order 1-3. Use the nail to plug in keep the rib on the paper plan and add CA glue. Rounded the edge around of Elevator by sanding tool (Photo 9).

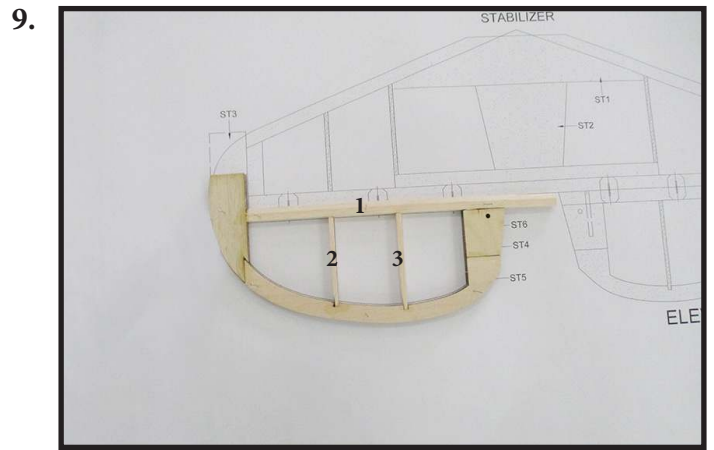

Locate position of paper hinge for Stabilizer and Elevator as plan. Then, sawn the slot (for 6 hinges) by the blade tool (Photo 10,11).

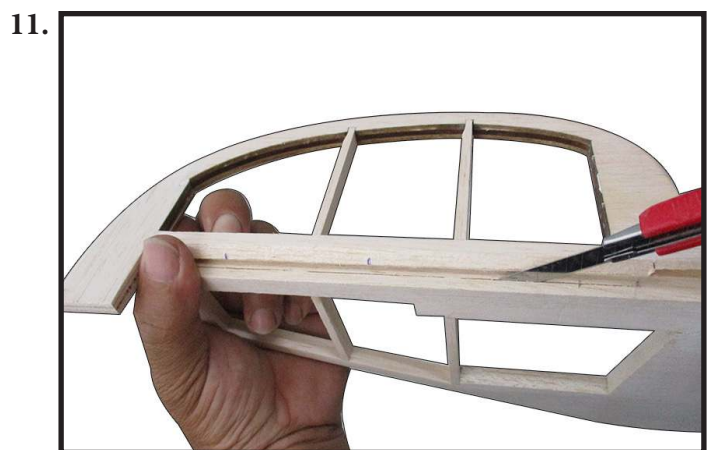
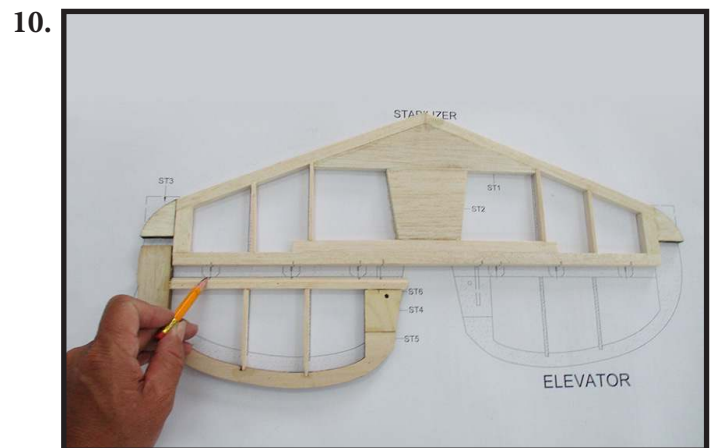

Locate position of metal elevator joiner wire. Then, drill the ( $\varnothing$  3mm) round well inside Elevator. The deep value of well is equal to dimension of the wire part which bends 90 degree angle like a hook. (Photo 12).

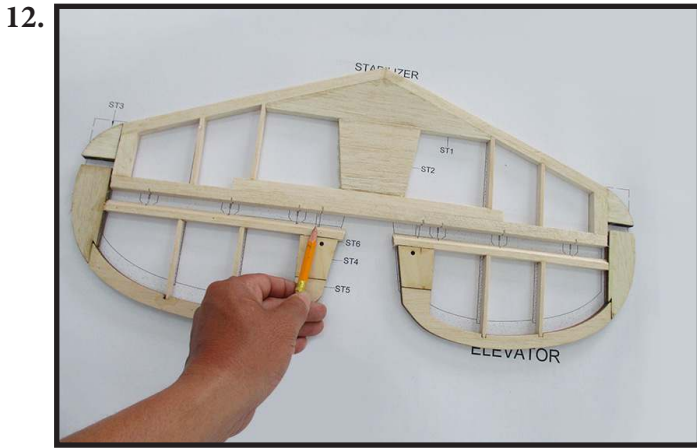

12. Finish set of horizon stab. (Photo 13).

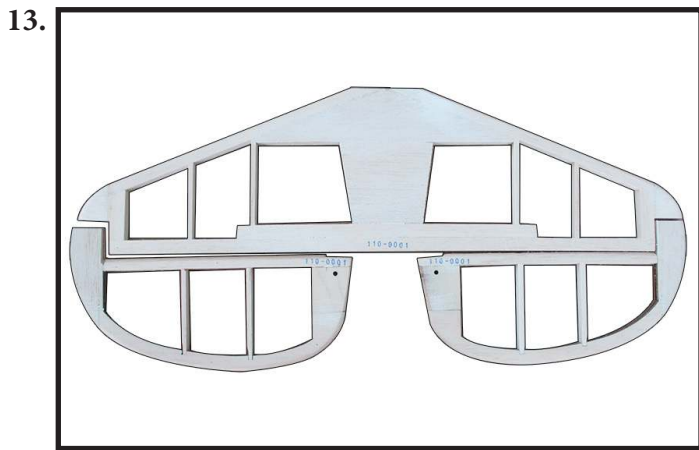

**FIN AND RUDDER**

Prepare for assemble the Fin and Rudder.

Balsa 8mm x 10mm x 500mm spars.

Balsa 8mm x 10mm x 300mm spars.

Balsa 3mm x 8mm x 100mm spars.

The laser cut special parts are available from code T1- T5.

Locate and assemble the Fin as the plan. Step by step do it one after another in order 1-6. Use the nail to plug in keep the rib on the paper plan and add CA glue. (Photo 1).

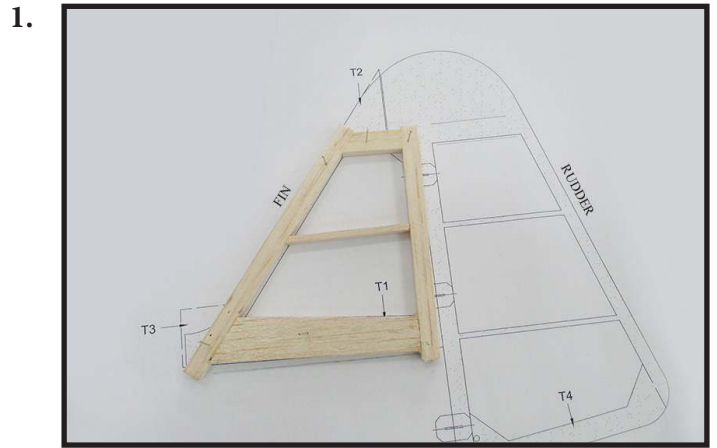

1. Locate and assemble the Rudder as the plan. Step by step do it one after another in order 1-6. Use the nail to plug in keep the rib on the paper plan and add CA glue. Remove nail after glue dries (Photo 2).

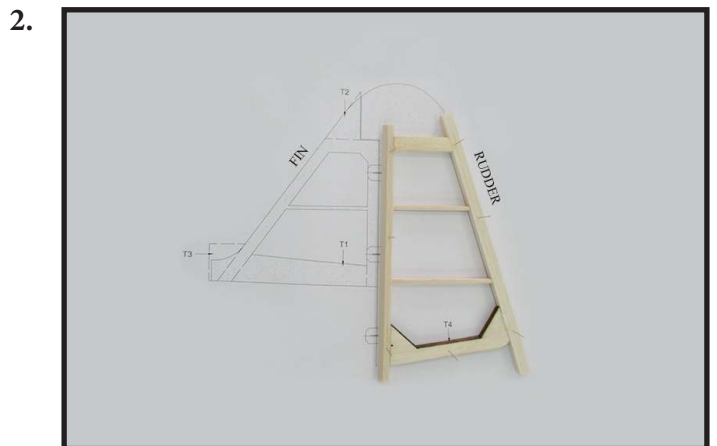

2. Cut off the excess balsa wood part and sanding smooth and flat the edge. (Photo 3).



3.

Locate and assemble T1 as the (photo 4).

4.

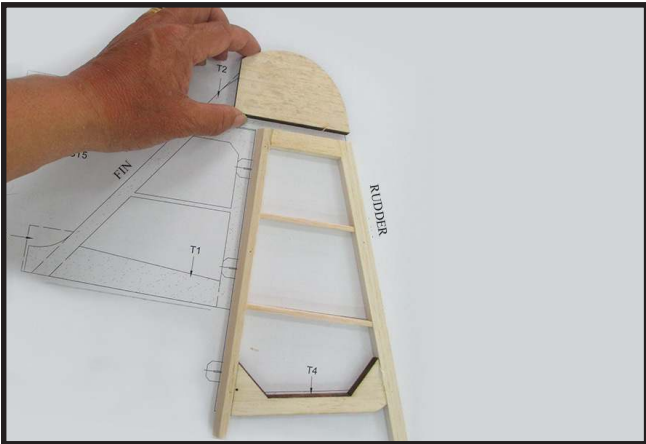

Cut off the excess balsa wood part, rounded the edge around of Fin and Rudder by sanding tool. (Photo 5).

5.

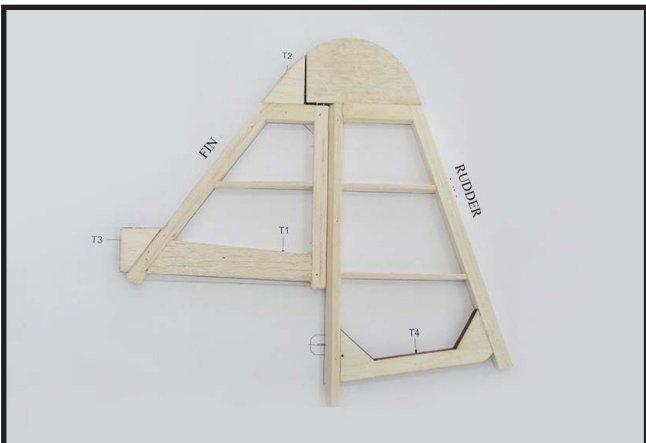

Locate position of paper hinge for Fin and Rudder as plan. Then, sawn the slot (for 3 hinges) by the blade tool (Photo 6,7).

6.

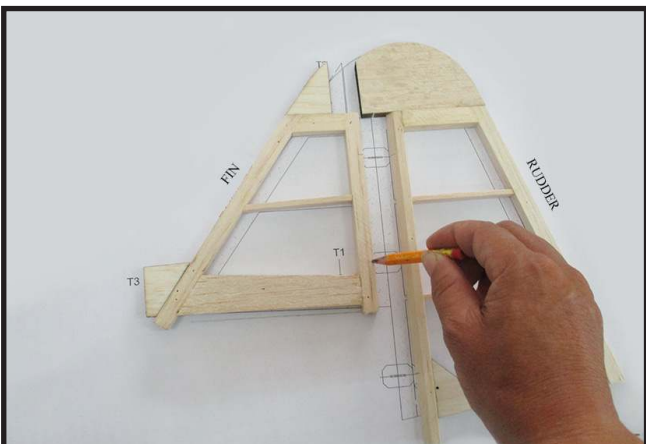

7.

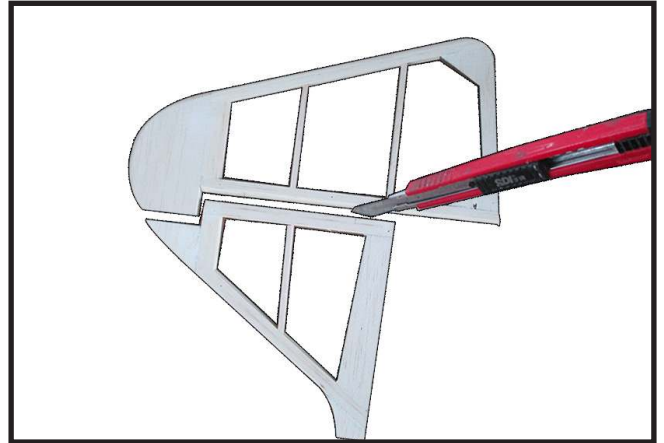

SET UP

Sanding to smooth (not rough) at interface on fuselage (the edges of fuselage where the wing panel intersect to the fuselage) as photo shown (Photo 1).

1.

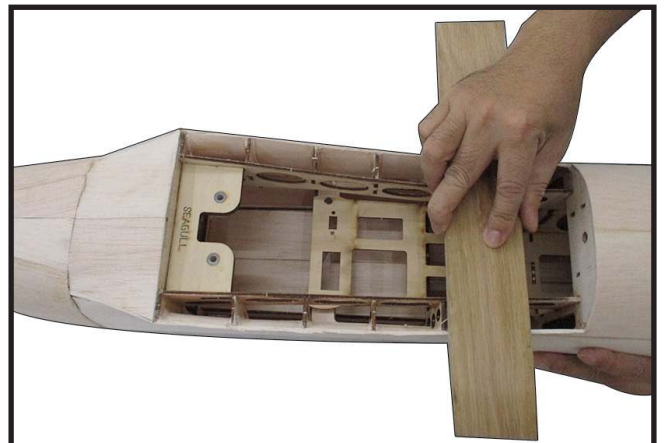

Cover the ribs at interface by SH9 sheet (Photo 2).

2.

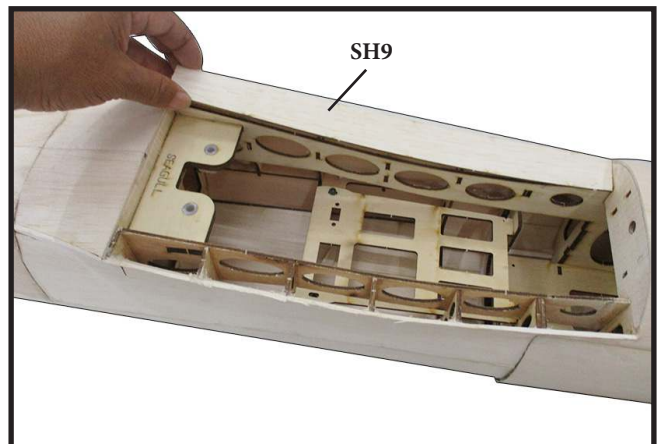

Locate and assemble the 8mm dowel at wing root of center wing for two sides (left and right) as (photo 3).

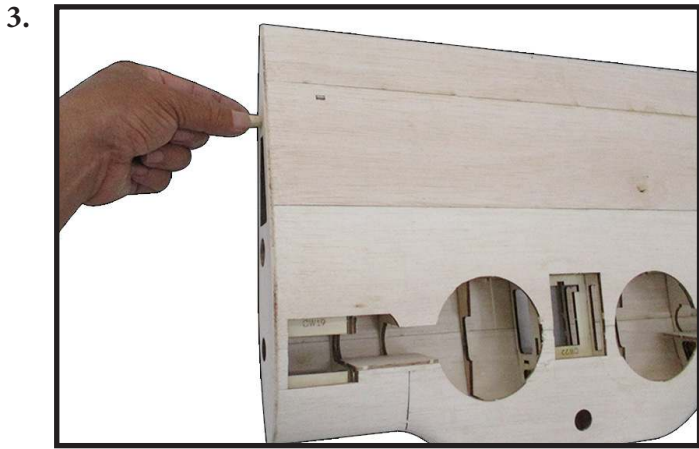

Attach to the pen through from hole on F1, F2 go on until it touch the front of wing to take the ink mark. This is position of the 8mm dowel on wing. Attach dowel into wing so that dimension of a remaining dowel part outside is 10mm (Photo 4,5).

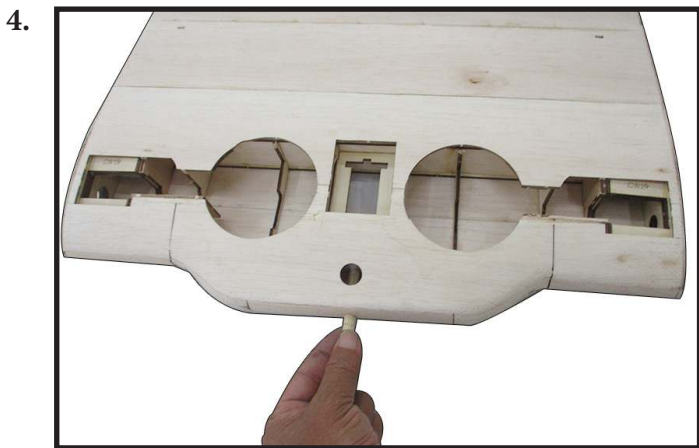

Use the sharp screw to take point of mark so that locating of hole. Then, put the wing on fuselage and light press down at the sharp (take two points). Next step, from the center point drill two holes(Ø 6mm) These are the bolt hole so that fixed wing to fuselage. (Photo 6 ,7).

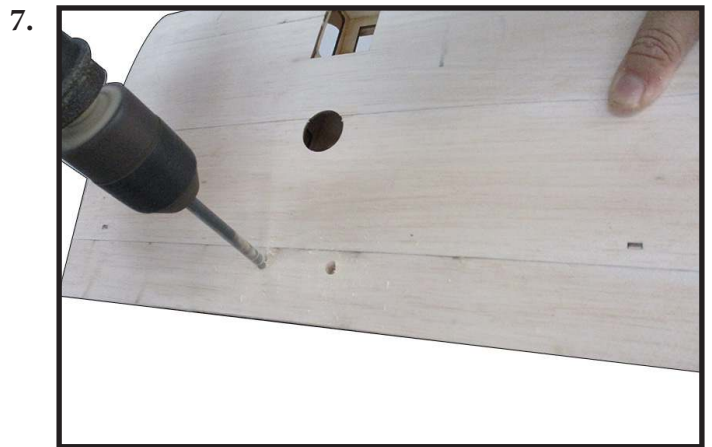

Attach down by two bolts M6x45 and ring washer to install wing to fuselage. (Photo 8).



Apply F17 at rear of fuselage. Then, sanding rounded as (photo 9).

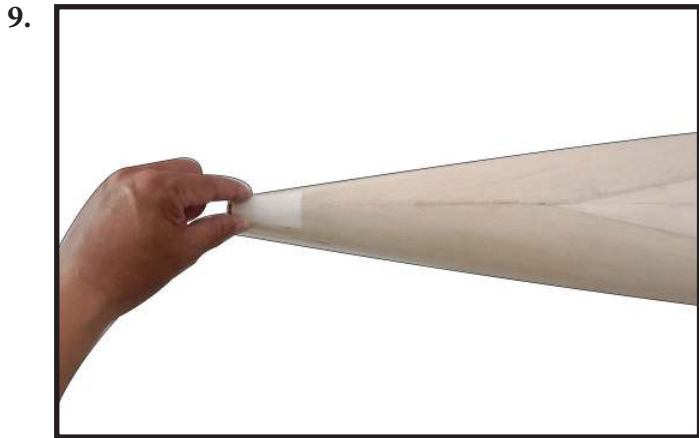

Apply F14B at fuselage as (photo 13).

Assemble F14A at rear of fuselage at intersect to stabilizer as (photo 10).

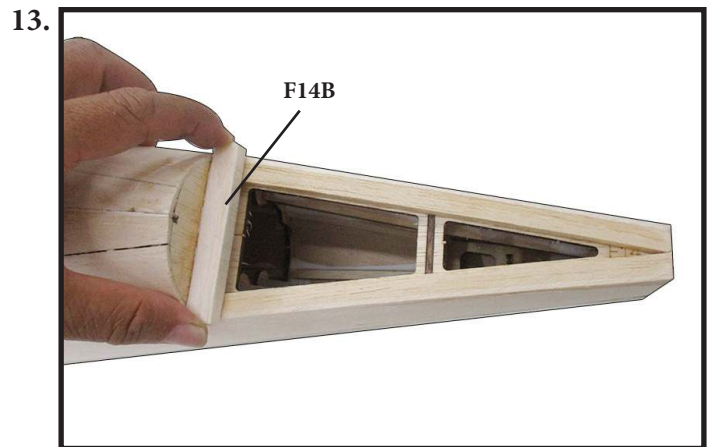
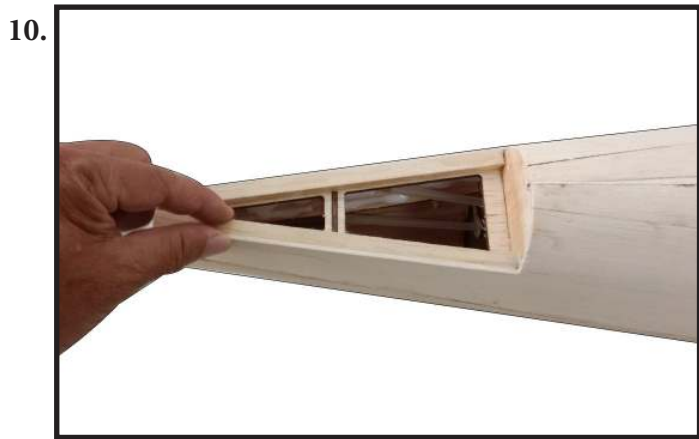

Install the Stabilizer to fuselage. Then apply F40 at rear so that the gap (between stabilizer and F40) is 5mm. This gap is position where insert metal joiner tool of elevator. (photo 14).

Use Model incidence meter tool as photo show, so that setting proper thrust for wing and stabilizer are 0 degree. First, measure incidence of wing. Then, sanding the stabilizer until incidence of thrust is equal to wing, not misalignment. (Photo 11, 12).

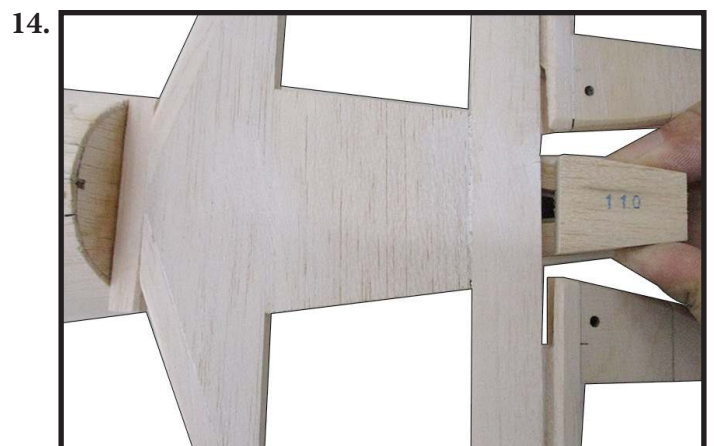

Prepare the part with item code F18 - F22 for the box of Fin. (Photo 15).

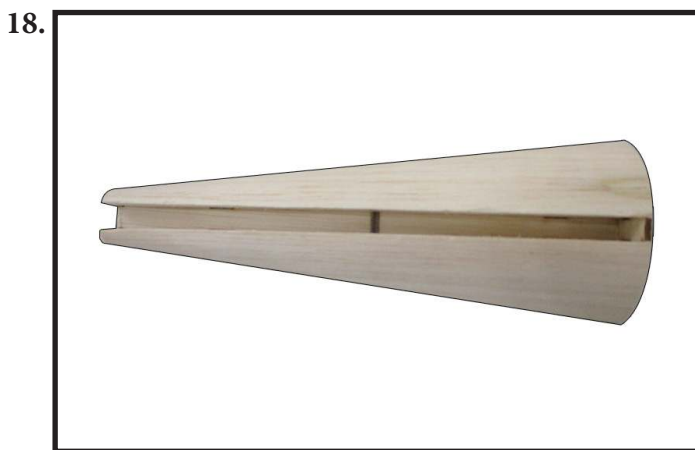
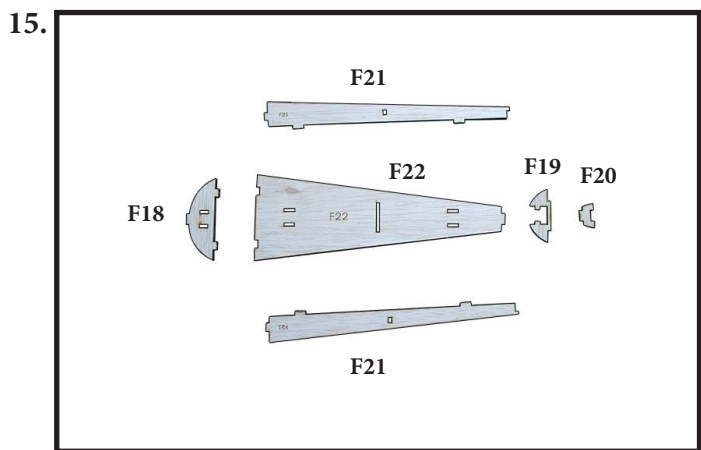

Locate and assemble as (photo 16).

Install the box of fin to fuselage. Then, install the fin to slot of box. Push the fin toward rear to end of fuselage. Insert T3 to slot of box, front the fin. (Photo 19,20).



Cover sheet SH10 (2 sides) as (photo 17,18).

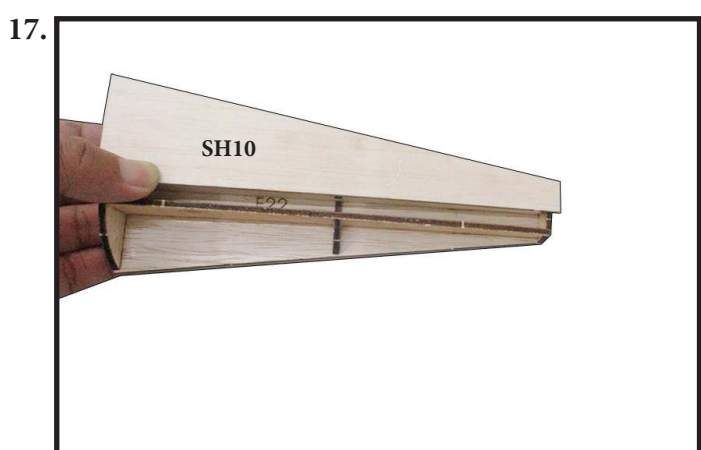

Finish Setup. (Photo 21).



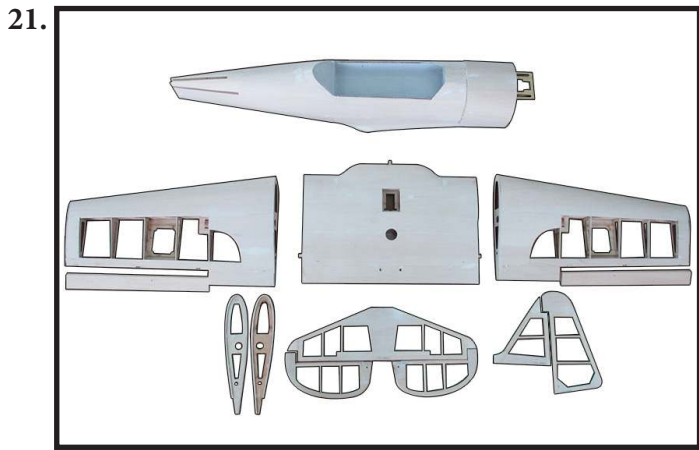

Locate and attach two plastic gear fix pieces to the plywood gear door as (photo 22).

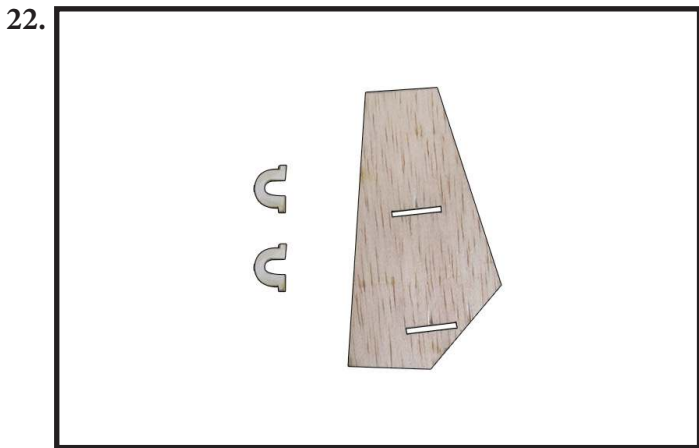

Locate and assemble F38 (simulation control panel at cockpit area) to the plastic frame. (Photo 23).



Cut down the excess plastic part and sanding for the plastic frame seamless to surface of the simulation control panel as (photo 24).



Locate and assemble the part 1mm plastic (the cockpit simulation detail) to become the plastic frame. (Photo 25,26,27,28).

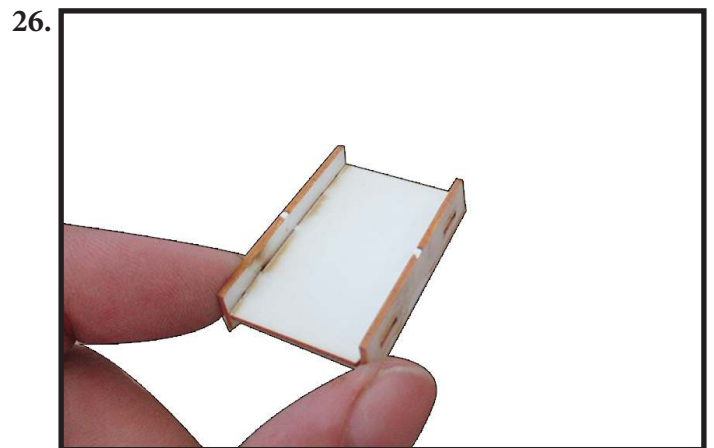
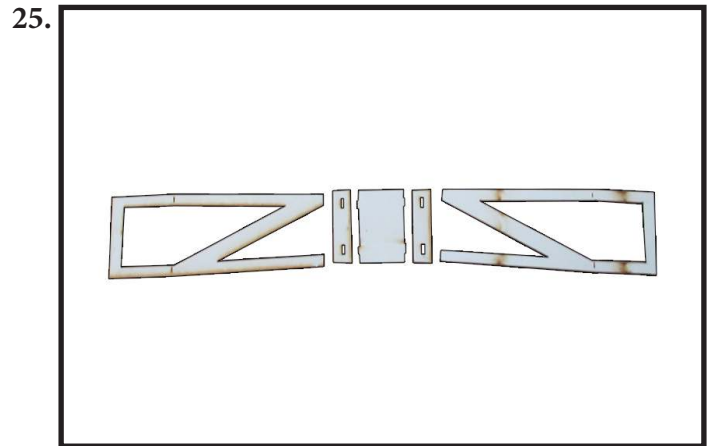

27.

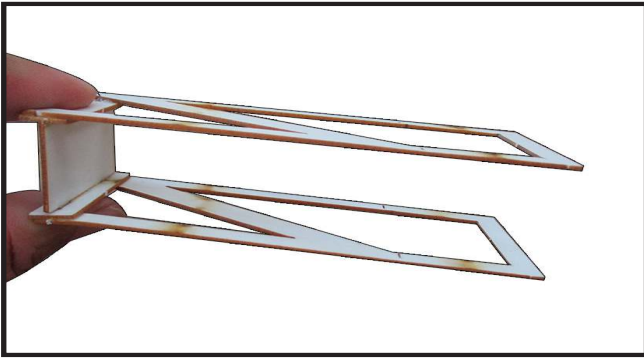

28.

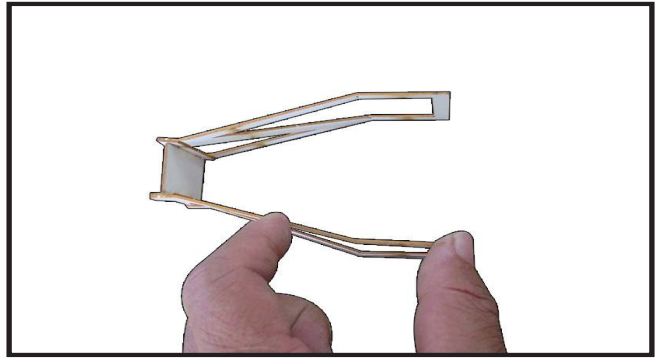

### FINAL ASSEMBLY.

**NOTE:** To avoid scratching your new aero plane we suggest that you cover your workbench with an old towel. Keep a couple of jars or bowls handy to hold the small parts after you open the bags. Please trial fit all parts. Make sure you have the correct parts and that they fit and are aligned properly before gluing! This will ensure proper assembly as the Master Scale kit Edition AT-6 Texan 63" 10-15cc is made from natural materials and minor adjustments may have to be made. The paint and plastic parts used in this kit are fuel proof. However, they are not tolerant of many harsh chemicals including the following: paint thinner, cyanoacrylate glue accelerator, cyanoacrylate glue de-bonder and acetone. Do not let these chemicals come in contact with the colours on the covering and the plastic parts.

#### ADDITIONAL ITEMS REQUIRED.

- 10-15cc.  
.40-.52 cu.in 2-stroke engine.  
.72-.82cu.in 4-stroke engine.
- 6 channels with 6 servos.
- Computer radio with nine servos.
- Glow plug to suit engine.
- Propeller to suit engine.
- Protective foam rubber for radio system.
- Silicone fuel line.

#### TOOLS & SUPPLIES NEEDED.

- Thick cyanoacrylate glue.
- 30 minute epoxy.
- 5 minute epoxy.
- Hand or electric drill.
- Assorted drill bits.
- Modelling knife.
- Straight edge ruler.
- 2mm ball driver.
- Phillips head screwdriver.
- 220 grit sandpaper.
- 90° square or builder's triangle.
- Wire cutters.
- Masking tape & T-pins.
- Thread-lock.
- Paper towels.

#### PARTS LISTING.

##### FUSELAGE ASSEMBLY

- (1) Fuselage.
- (1) Canopy.

##### WING ASSEMBLY

- (1) Right wing half/ aileron.
- (1) Left wing half/ aileron.
- (1) Middle wing.

##### Tail section assembly

- (1) Horizontal stabilizer/ elevator halves.
- (1) Rudder halves.

##### Some more parts.

##### HARDWARE PACK

##### COWLING

Landing gear.....

**NOTE:** To avoid scratching your new aeroplane we suggest that you cover your workbench with an old towel. Keep a couple of jars or bowls handy to hold the small parts after you open the bags.

Please trial fit all parts. Make sure you have the correct parts and that they fit and are aligned properly before gluing! This will ensure proper assembly as the **AT-6 TEXAN** is made from natural materials and minor adjustments may have to be made. The paint and plastic parts used in this kit are fuel proof. However, they are not tolerant of many harsh chemicals including the following: paint thinner, cyano-acrylate glue accelerator, cyanoacrylate glue de-bonder and acetone. Do not let these chemicals come in contact with the colours on the covering and the plastic parts.

## HINGING THE AILERONS.

**Note:** *The control surfaces, including the ailerons, elevators, and rudder, are prehinged with hinges installed, but the hinges are not glued in place. It is imperative that you properly adhere the hinges in place per the steps that follow using a high-quality thin C/A glue.*

- 1) Carefully remove the aileron from one of the wing panels. Note the position of the hinges.
- 2) Remove each hinge from the wing panel and aileron and place a T-pin in the center of each hinge. Slide each hinge into the aileron until the T-pin is snug against the aileron. This will help ensure an equal amount of hinge is on either side of the hinge line when the aileron is mounted to the wing panel.

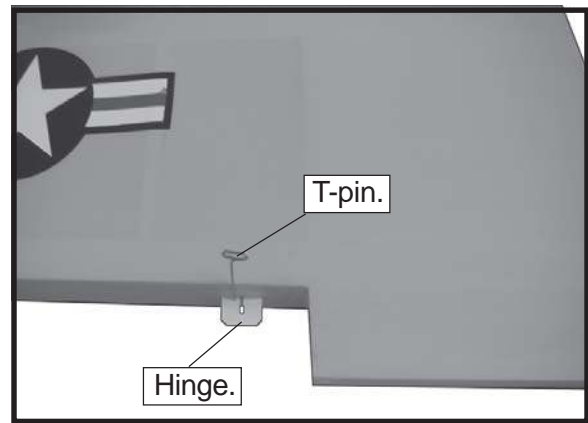

- 3) Slide the aileron on the wing panel until there is only a slight gap. The hinge is now centered on the wing panel and aileron. Remove the T-pins and snug the aileron against the wing panel. A gap of 1/64" or less should be maintained between the wing panel and aileron.

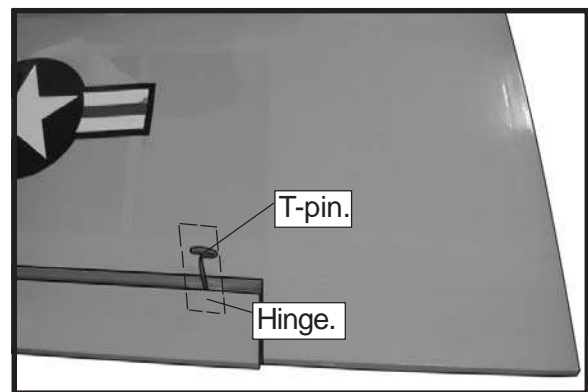

- 4) Deflect the aileron and completely saturate each hinge with thin C/A glue. The ailerons front surface should lightly contact the wing during this procedure. Ideally, when the hinges are glued in place, a 1/64" gap or less will be maintained throughout the length of the aileron to the wing panel hinge line.

**Note:** *The hinge is constructed of a special material that allows the C/A to wick or penetrate and distribute throughout the hinge, securely bonding it to the wood structure of the wing panel and aileron.*

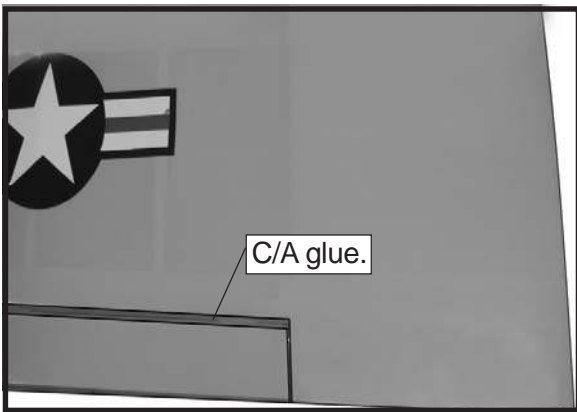

- 5) Turn the wing panel over and deflect the aileron in the opposite direction from the opposite side. Apply thin C/A glue to each hinge, making sure that the C/A penetrates into both the aileron and wing panel.
- 6) Using C/A remover/debonder and a paper towel, remove any excess C/A glue that may have accumulated on the wing or in the aileron hinge area.
- 7) Repeat this process with the other wing panel, securely hinging the aileron in place.
- 8) After both ailerons are securely hinged, firmly grasp the wing panel and aileron to make sure the hinges are securely glued and cannot be pulled out. Do this by carefully applying medium pressure, trying to separate the aileron from the wing panel. Use caution not to crush the wing structure.

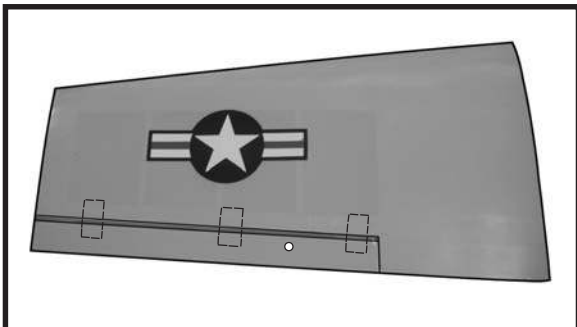

**Note:** *Work the aileron up and down several times to “work in” the hinges and check for proper movement.*

**HINGING THE ELEVATORS.**

Glue the elevator hinges in place using the same techniques used to hinge the ailerons.

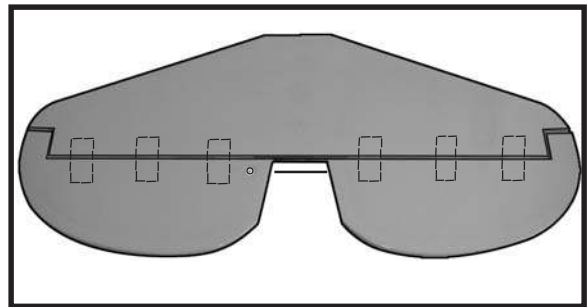
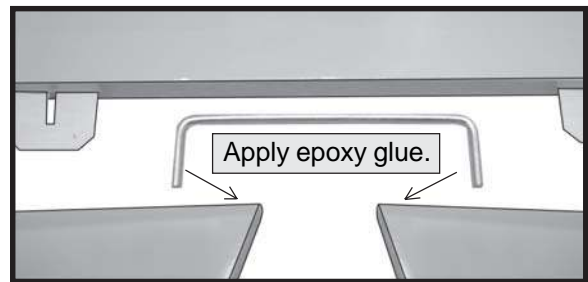
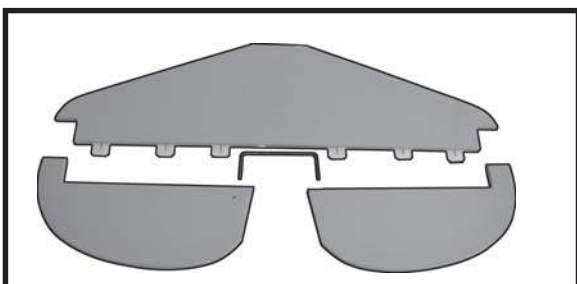

**HINGING THE RUDDER.**

Glue the rudder hinges in place using the same techniques used to hinge the ailerons.

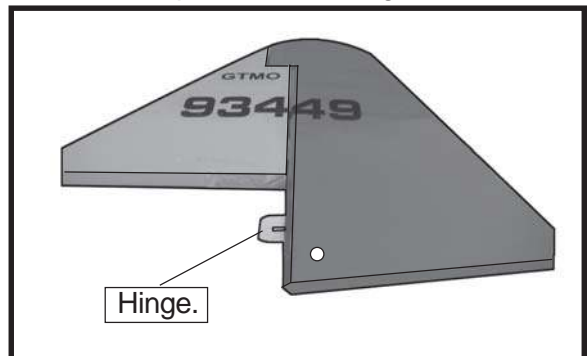

**WING TIP INSTALLATION .**

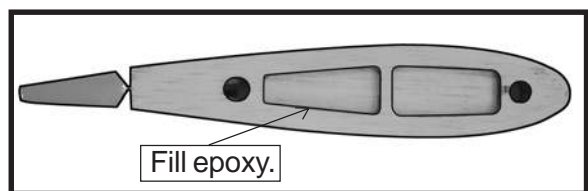
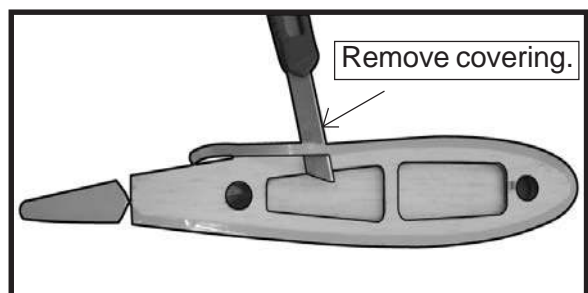
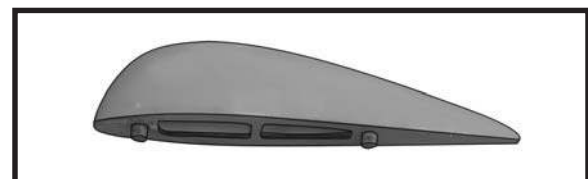

Install the wing edge to the wing.

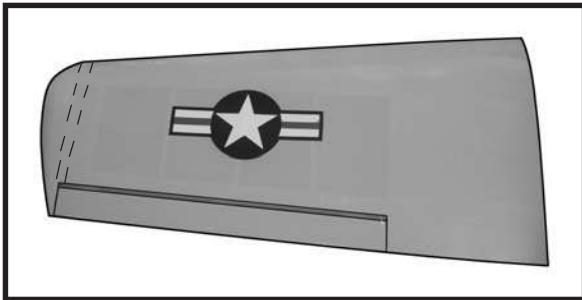
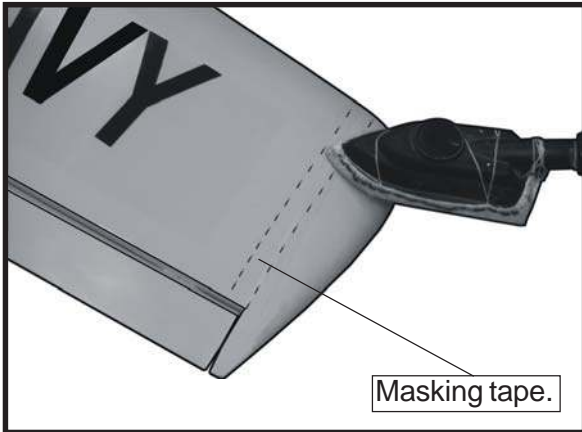
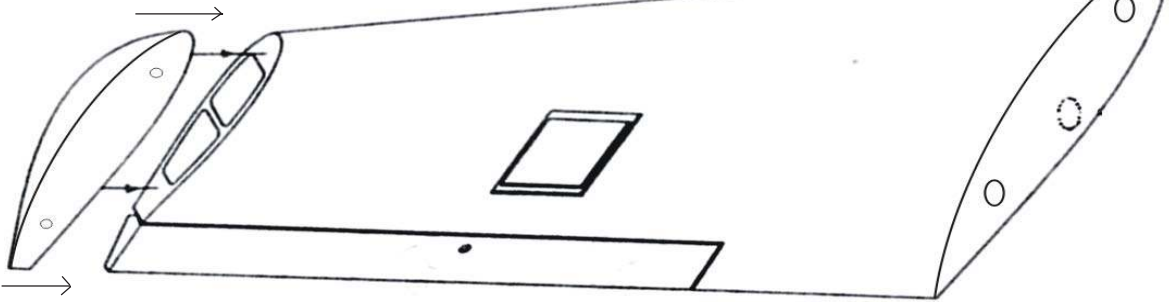

### AILERON CONTROL HORN

Aileron control horn: See pictures below.

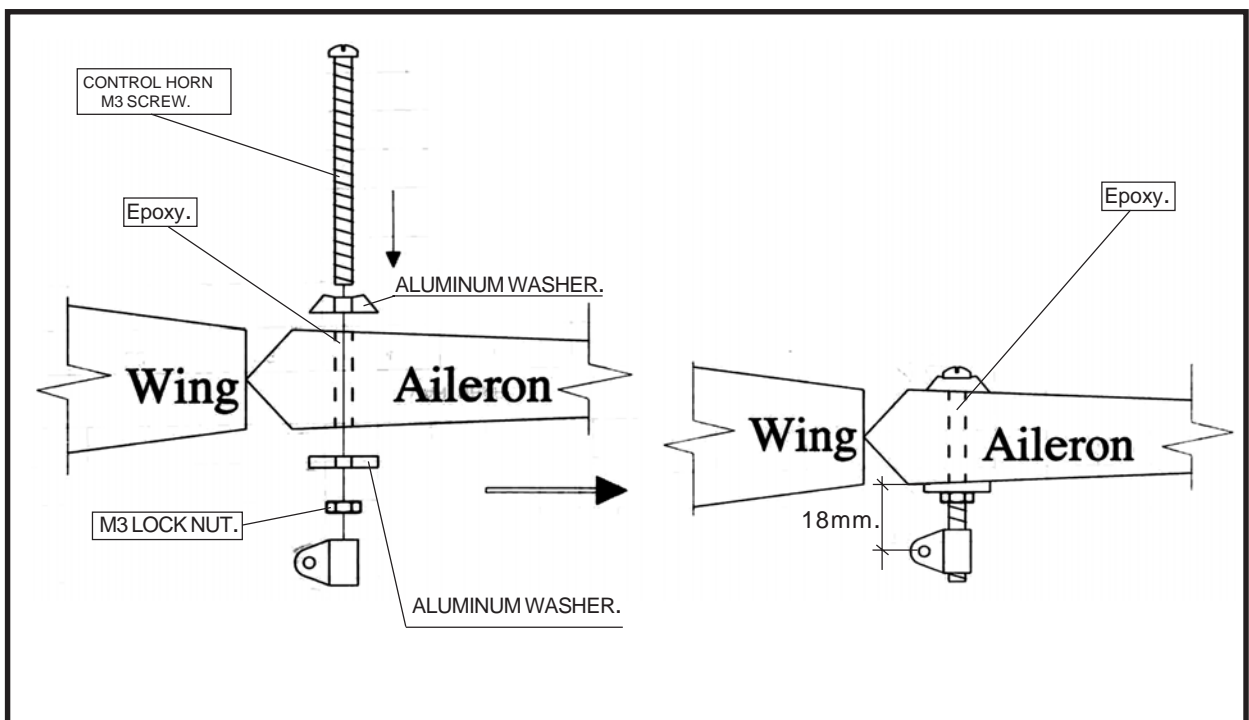
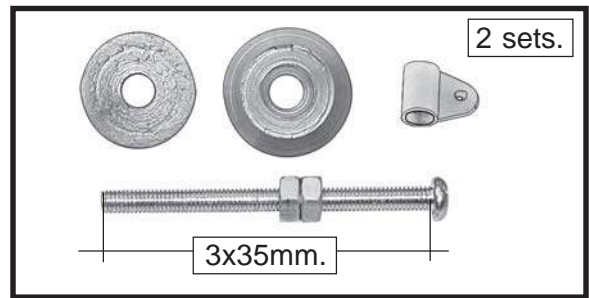

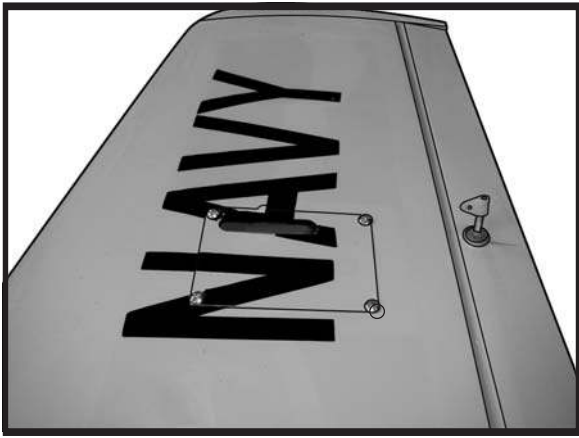

**ELEVATOR CONTROL HORN.**

Install the elevator control horn using the same method as with the aileron control horns.

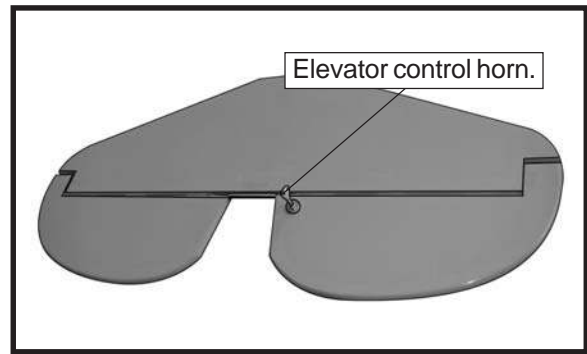
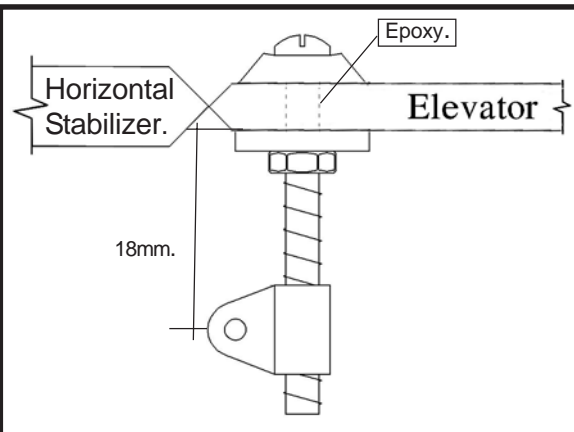
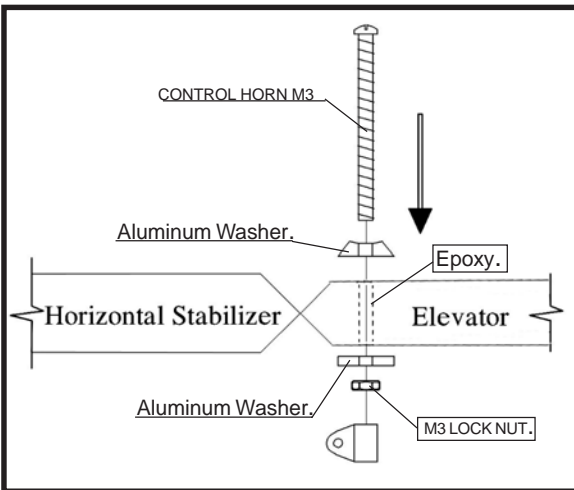
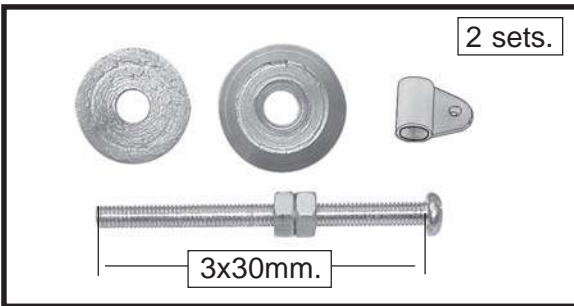

**RUDDER CONTROL HORN.**

Rudder control horn:  
Using the same techniques used aileron control horn. See picture below.

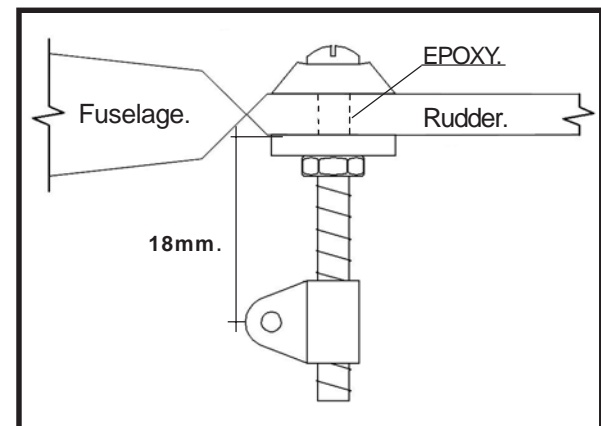
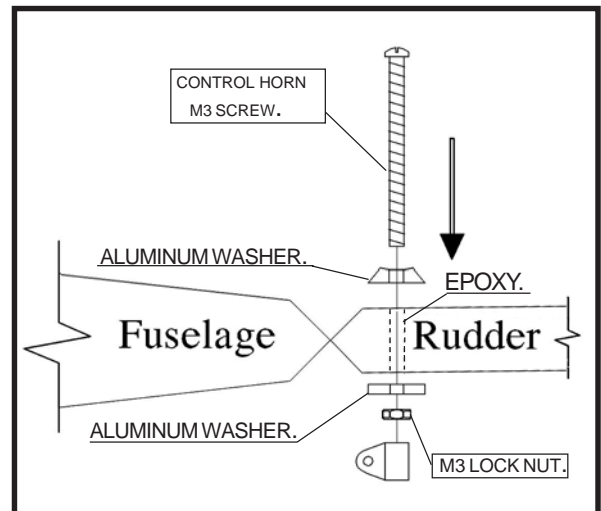
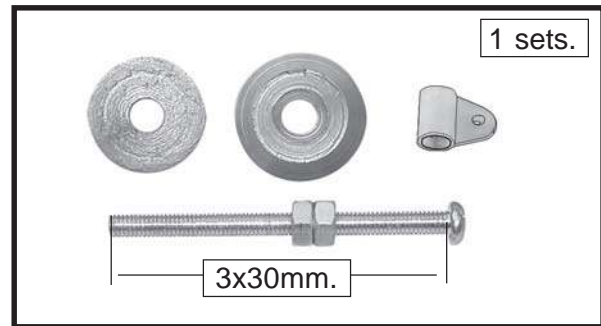

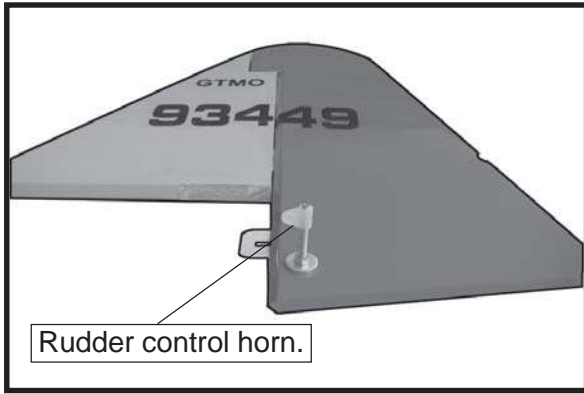

**SERVO GEAR INSTALLATION.**

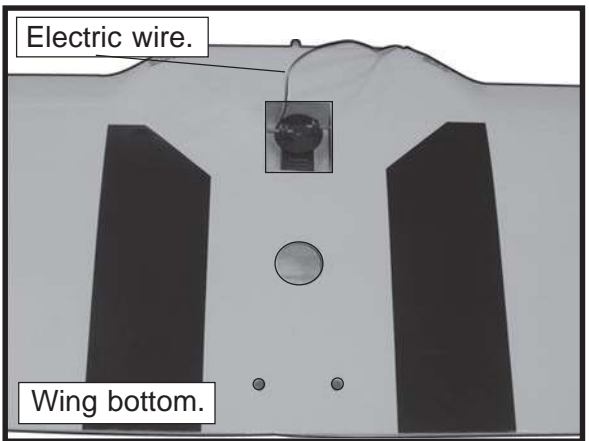
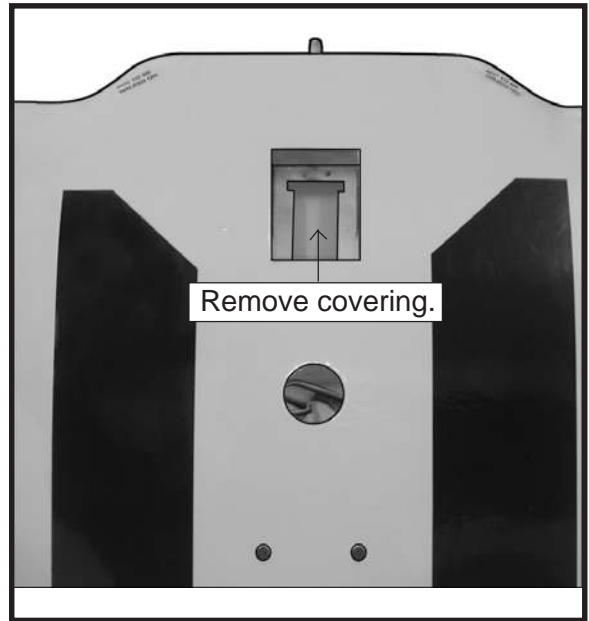

**PUSHROD INSTALLATION.**

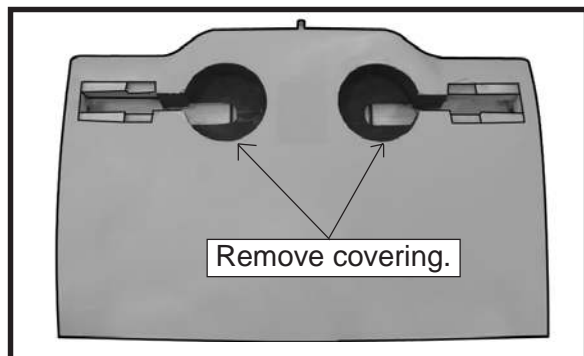
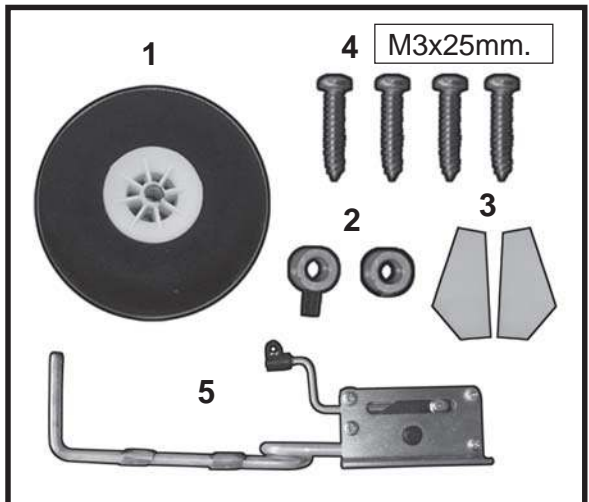
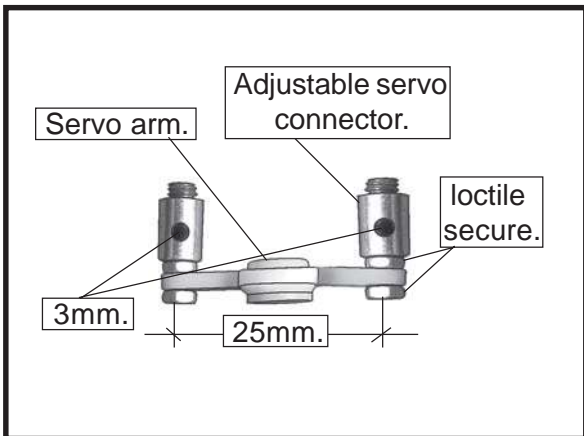

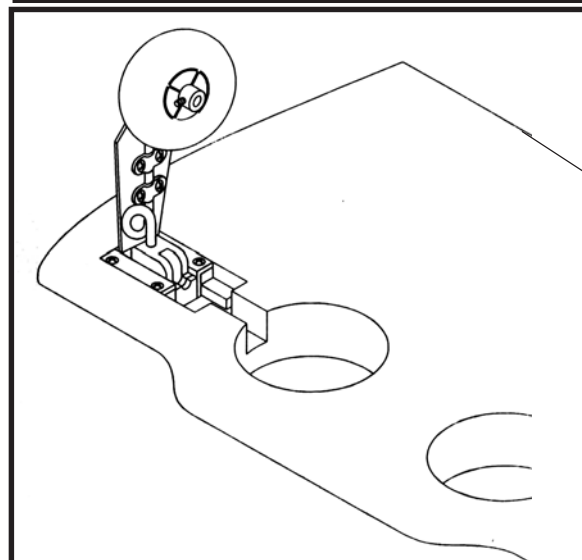
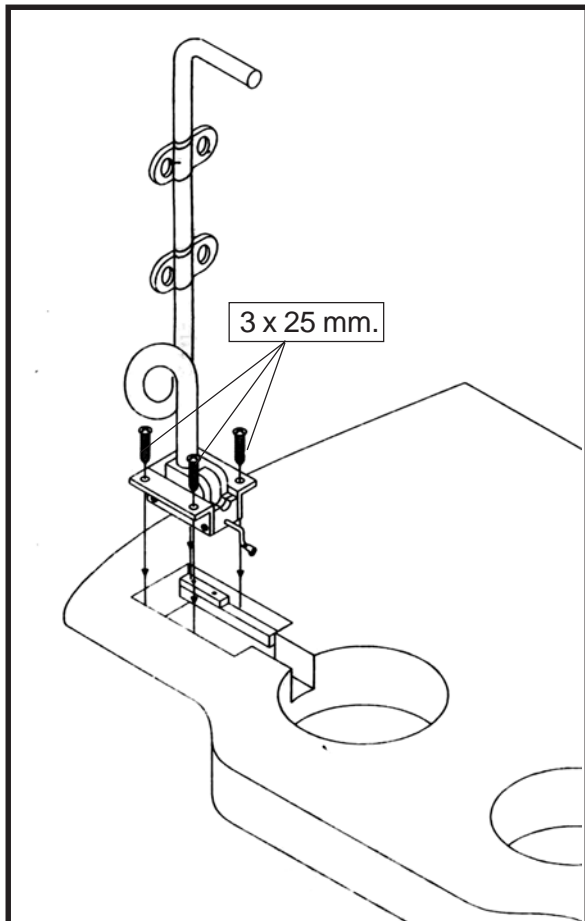
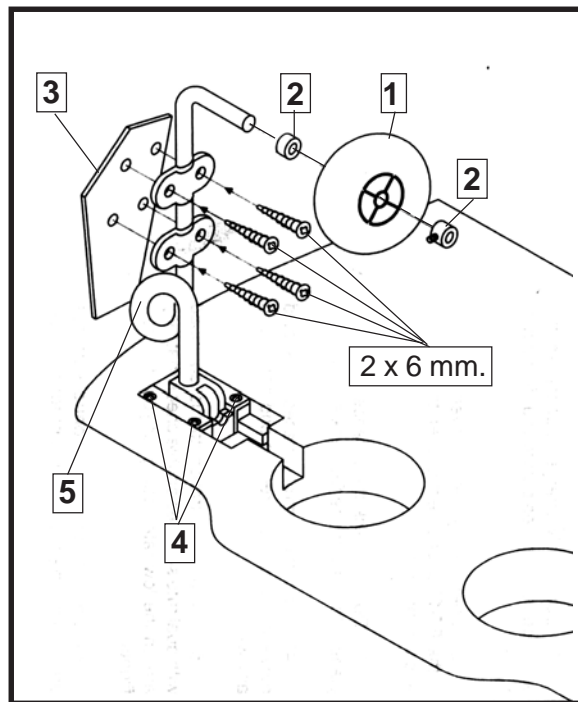
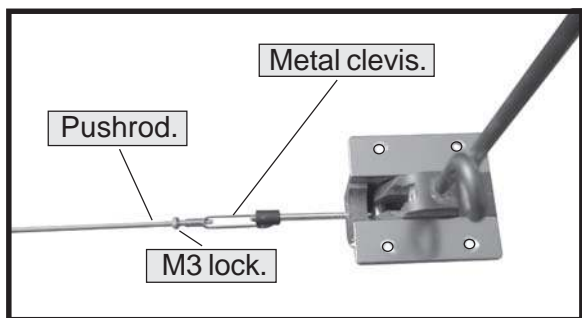

### Open Position

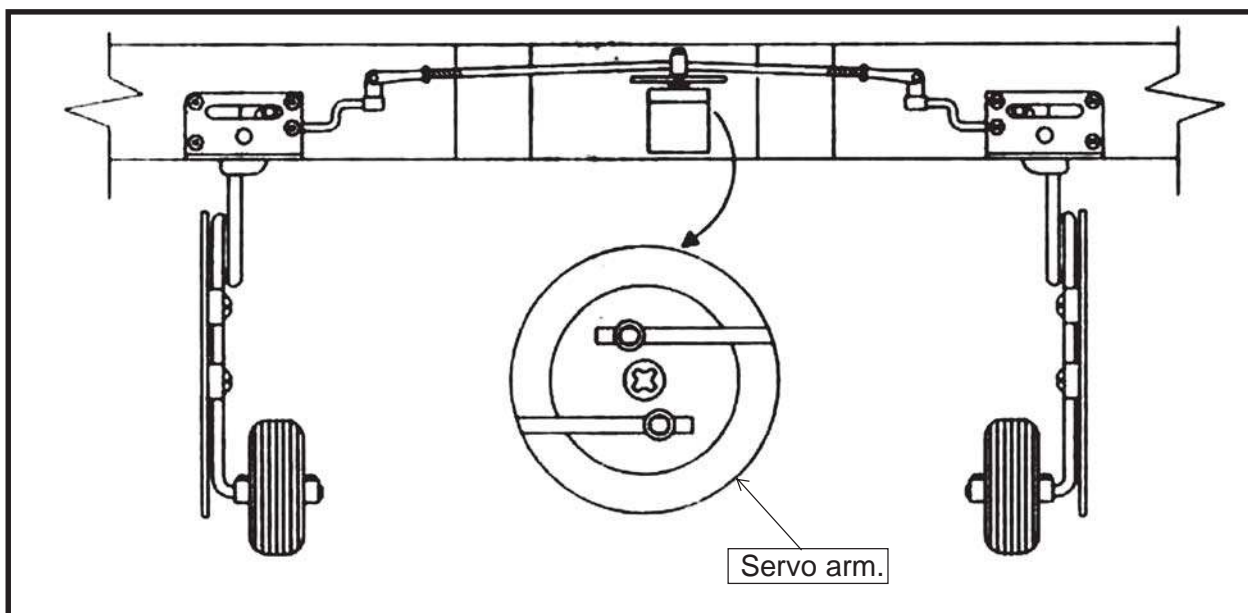



Close Position

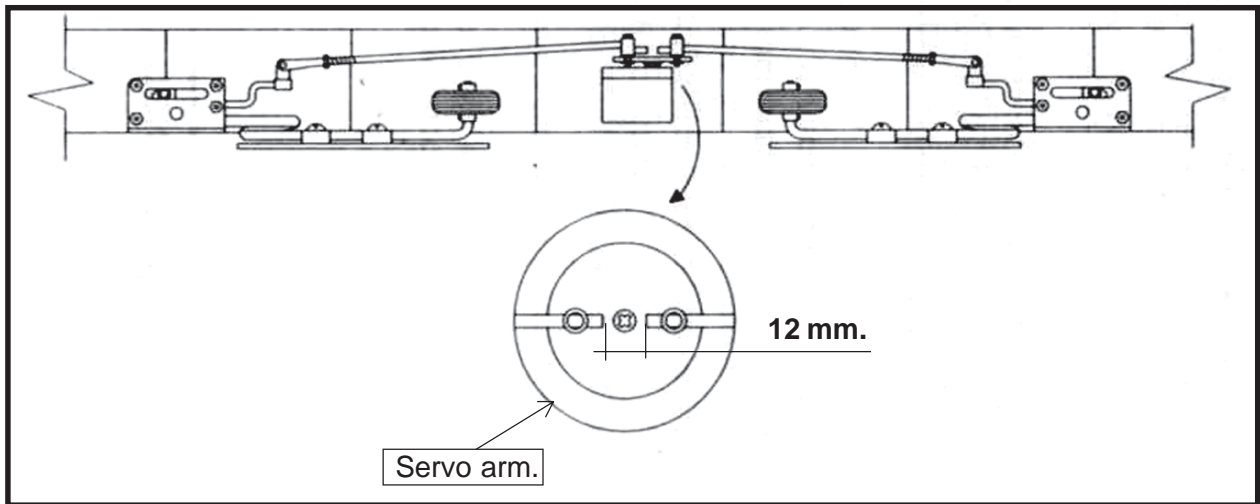

Repeat procedure for other landing gear.

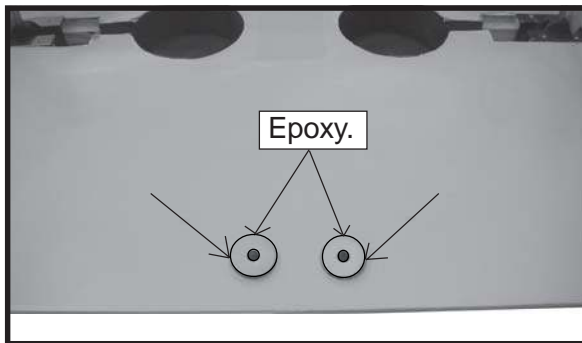

**WING ASSEMBLY.**

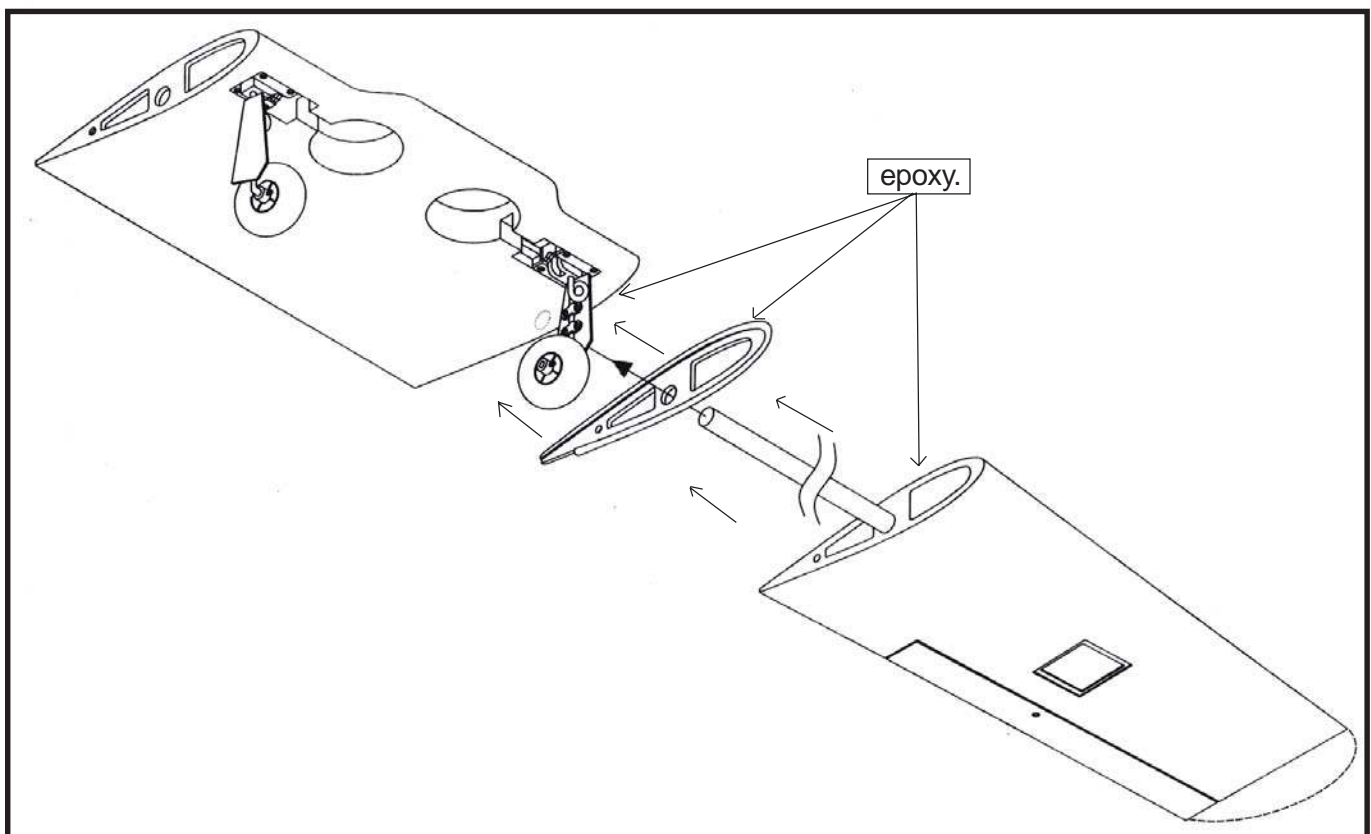

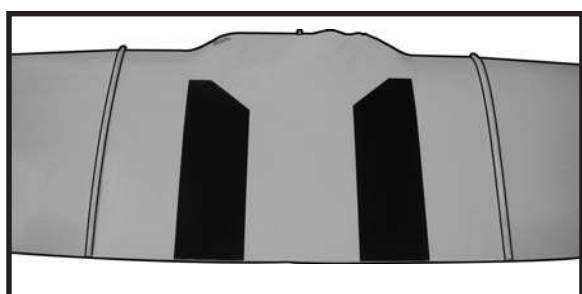
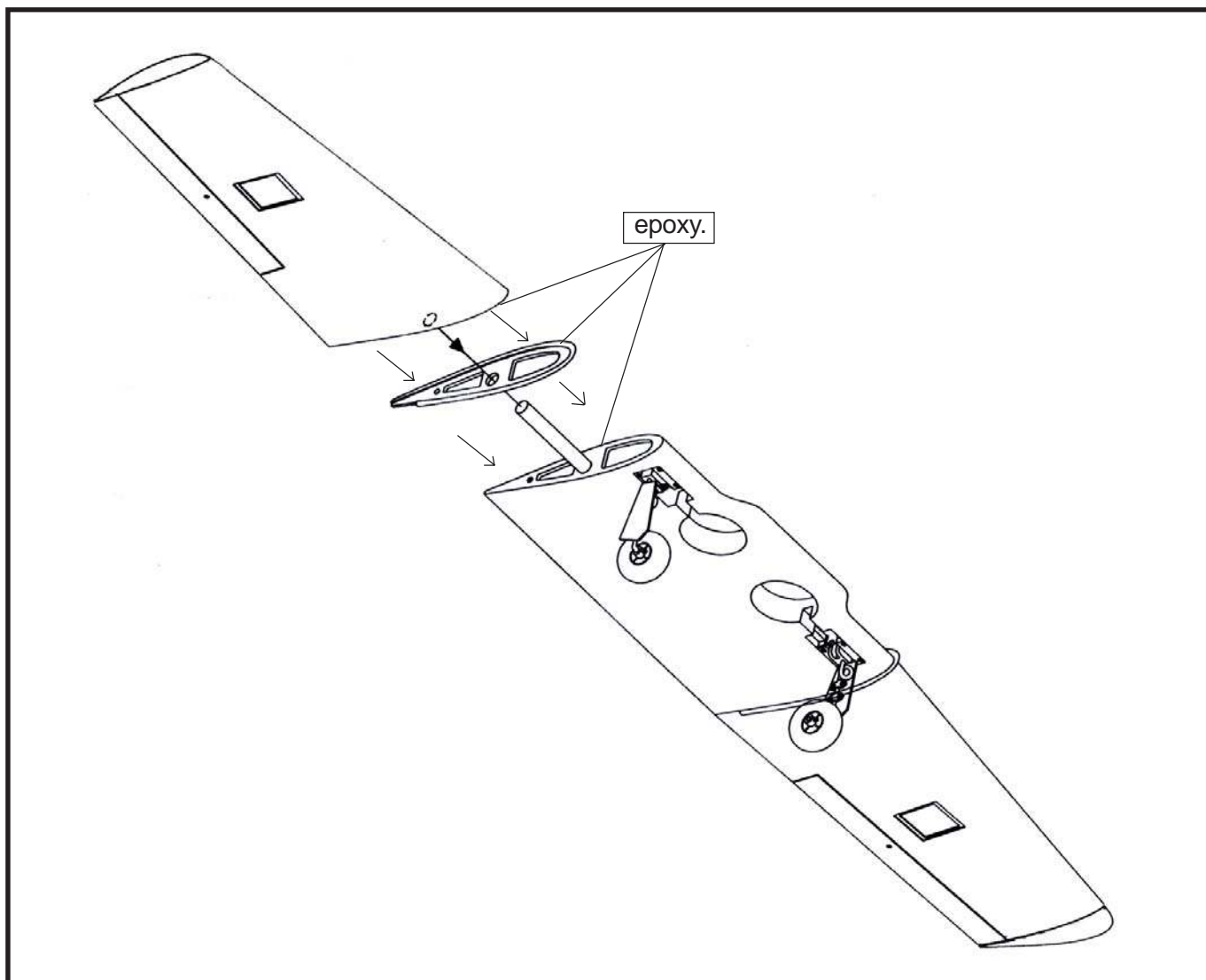

Mark and drill 4 holes for engine mount.  
Insert 4 blind nuts to firewall.

**ENGINE MOUNT INSTALLATION.**

See pictures below. Make yourself the template of your engine on paper.

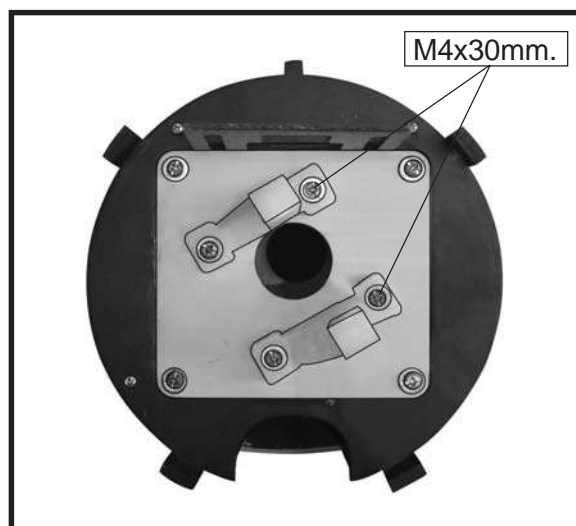
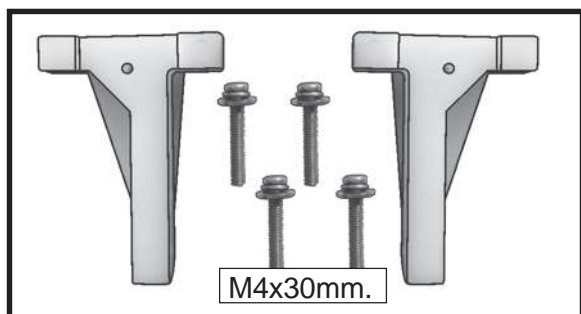

**INSTALLING THE STOPPER ASSEMBLY.**

- 1) Using a modeling knife, carefully cut off the rear portion of one of the 3 nylon tubes leaving 1/2" protruding from the rear of the stopper. This will be the fuel pick up tube.

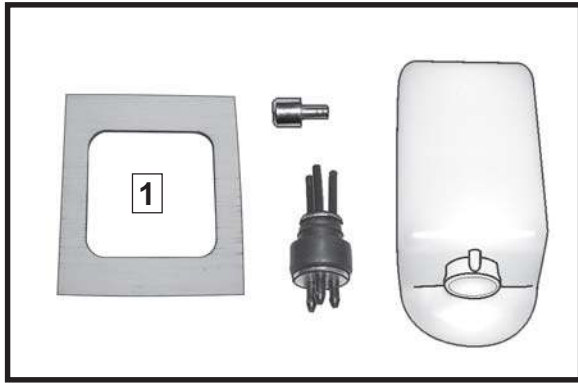

□2) Using a modeling knife, cut one length of silicon fuel line. Connect one end of the line to the weighted fuel pick up and the other end to the nylon pick up tube.

□3) Carefully bend the second nylon tube up at a 45° angle. This tube is the vent tube.

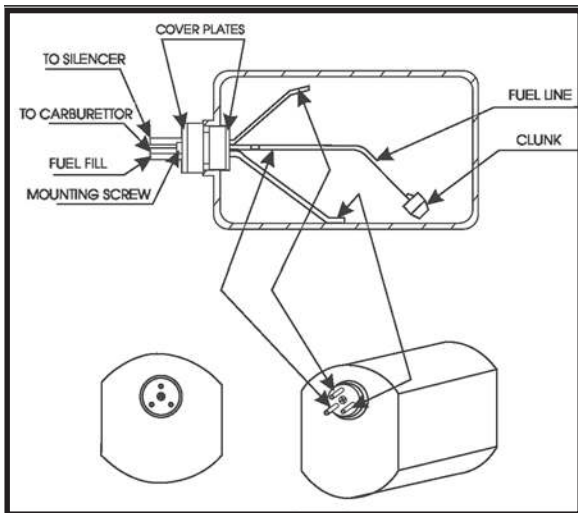

□ 4) Carefully heat the vent tube using a heat gun or lighter to permanently set the angle of the tube.

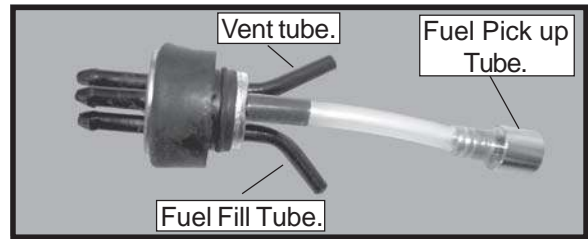

**⚠** *When the stopper assembly is installed in the tank, the top of the vent tube should rest just below the top surface of the tank. It should not touch the top of the tank.*

□ 5) Test fit the stopper assembly into the tank. It may be necessary to remove some of the flashing around the tank opening using a modeling knife. If flashing is present, make sure none falls into the tank.

□ 6) With the stopper assembly in place, the weighted pickup should rest away from the rear of the tank and move freely inside the tank. The top of the vent tube should rest just below the top of the tank. It should not touch the top of the tank.

□ 7) When satisfied with the alignment of the stopper assembly tighten the 3mm x 20mm machine screw until the rubber stopper expands and seals the tank opening. Do not overtighten the assembly as this could cause the tank to split.

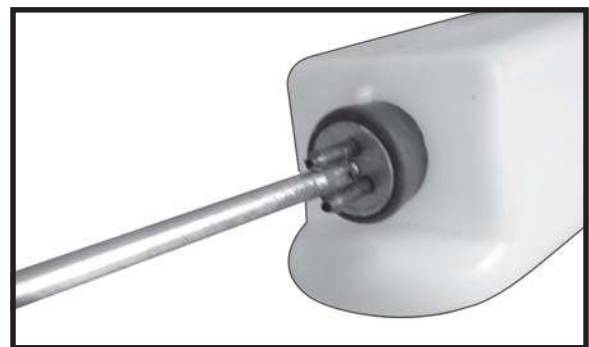

Attach the silicone fuel and pressure pipes to the tank. The lower pipe is the 'feed' and the upper two the 'pressure and fill'. The fill pipe is the next pipe.



You should mark which tube is the vent and which is the fuel pickup when you attach fuel tubing to the tubes in the stopper. Once the tank is installed inside the fuselage, it may be difficult to determine which is which.

Slide the tank into the fuselage from inside so that the neck is at the top of the fuselage and it locates through the engine bulkhead. Gently secure it to the top horizontal former with a cable tie.

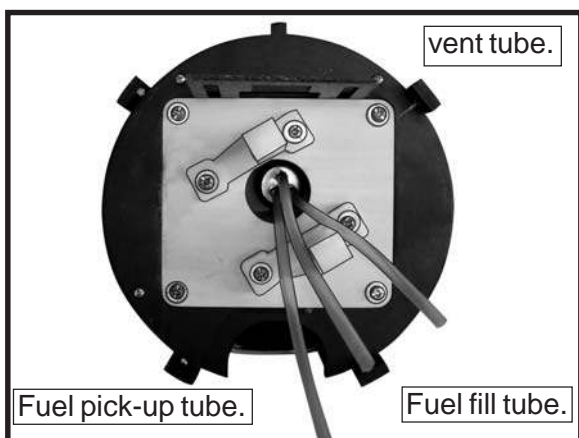
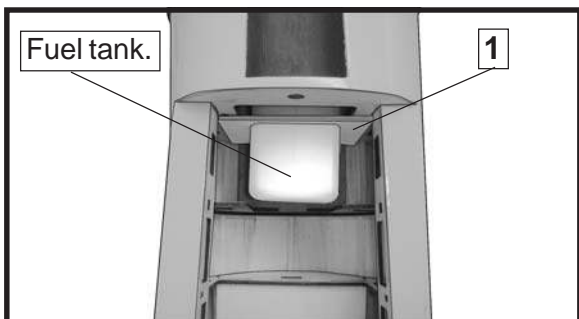
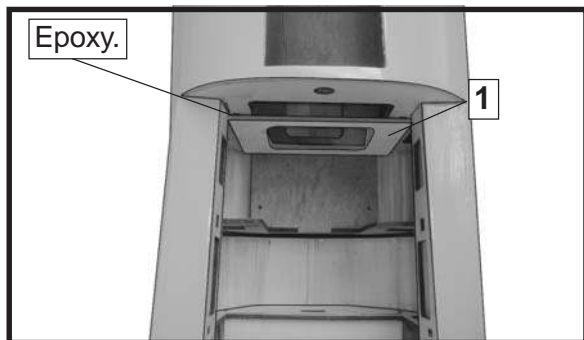

**!** Blow through one of the lines to ensure the fuel lines have not become kinked inside the fuel tank compartment. Air should flow through easily.

**INSTALLING THE BATTERY.**

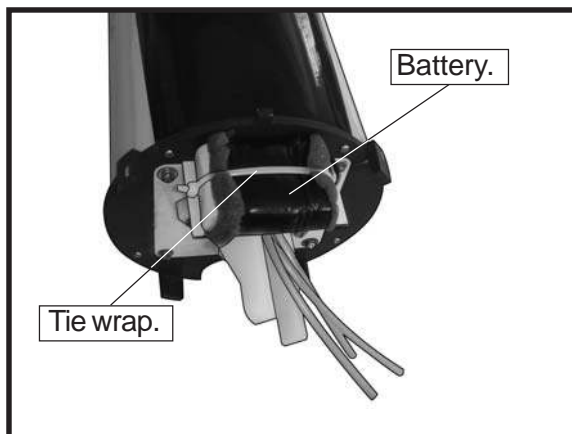

**MOUNTING THE ENGINE.**

*Engine 4 stroke :*

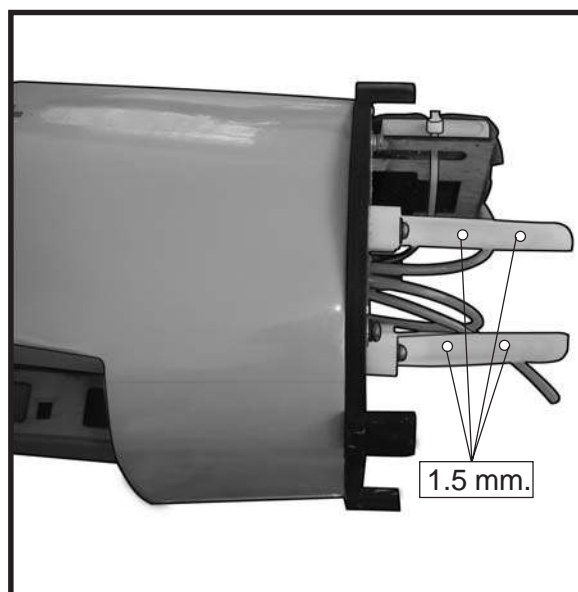
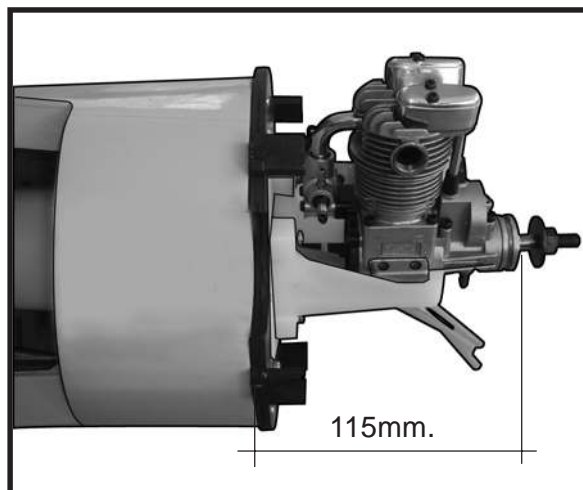

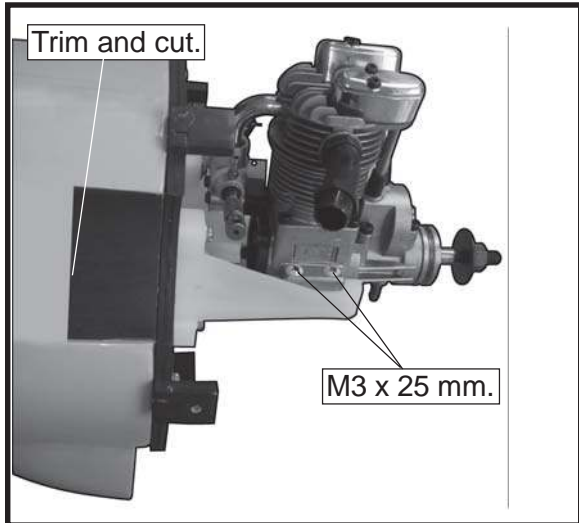
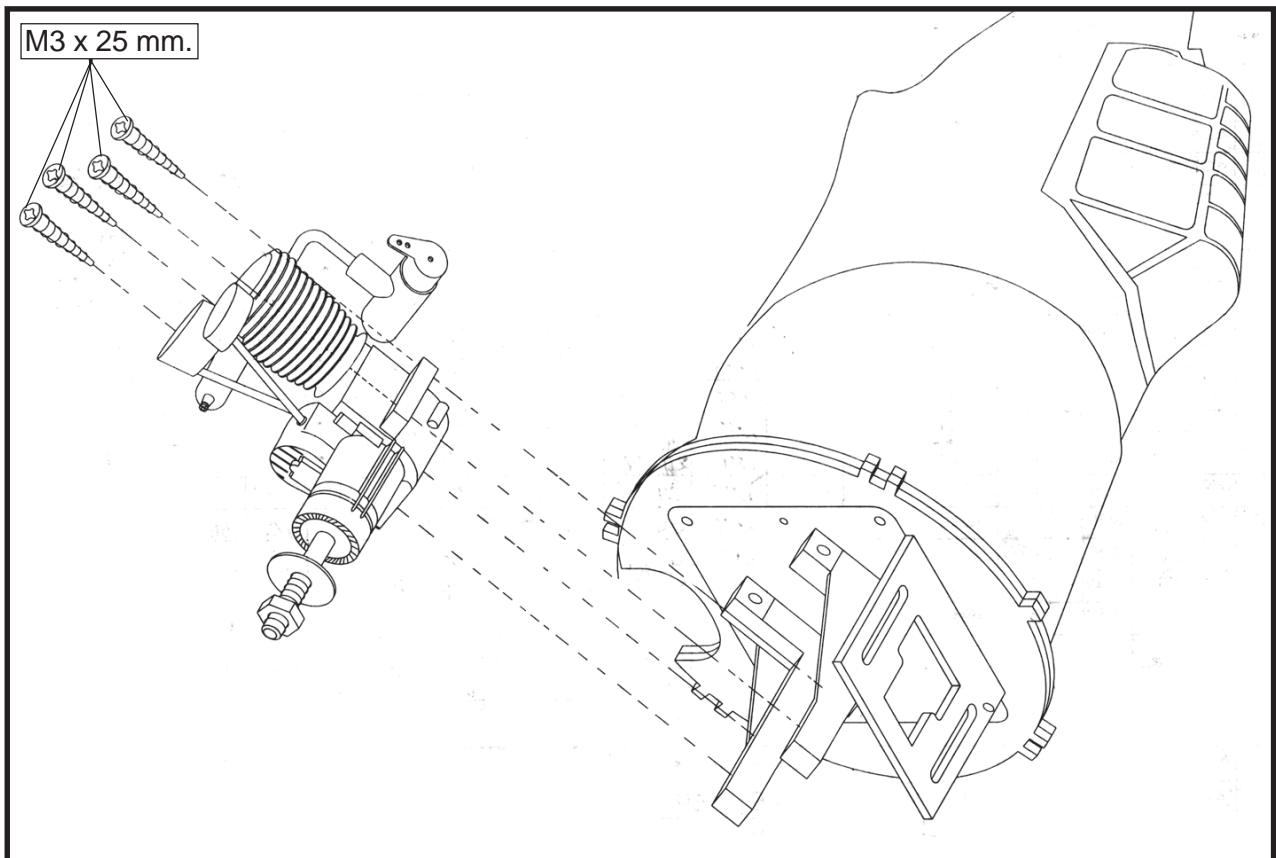

*Engine 2 stroke :*

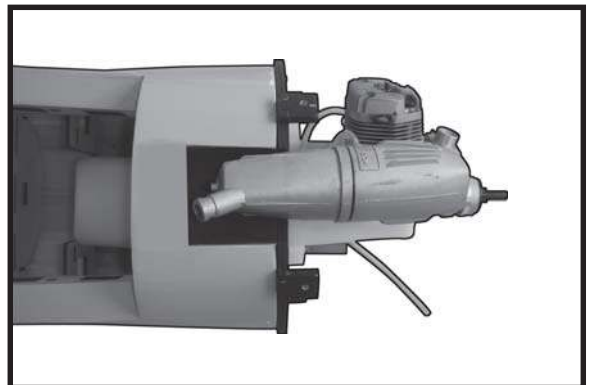
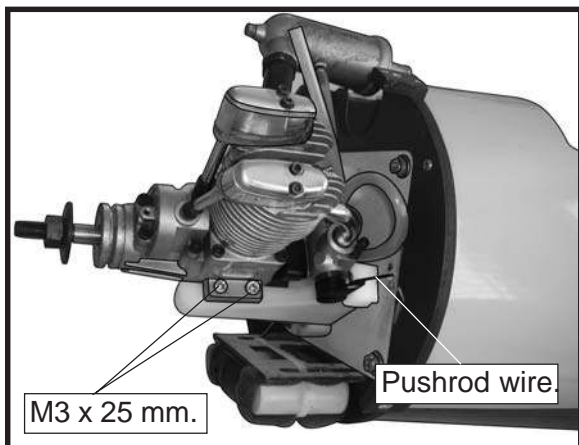
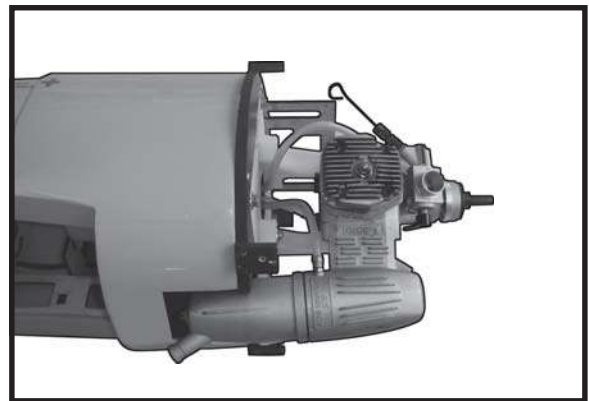

**COWLING.**

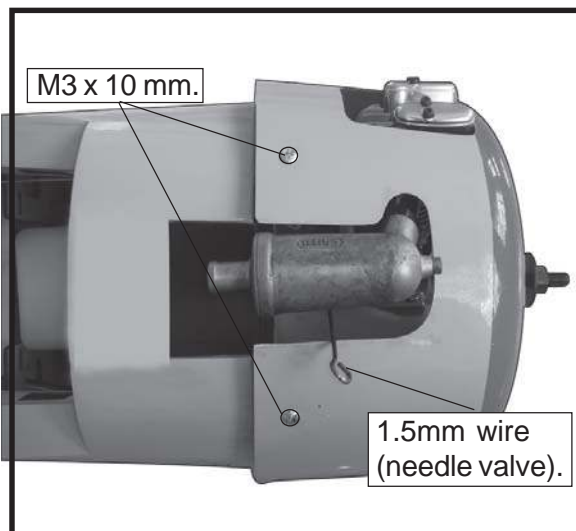
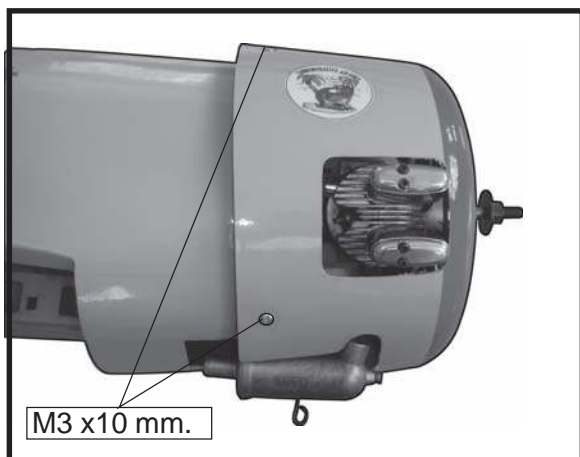
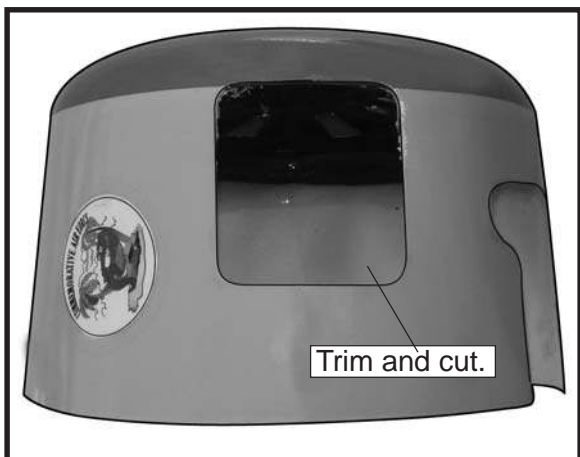
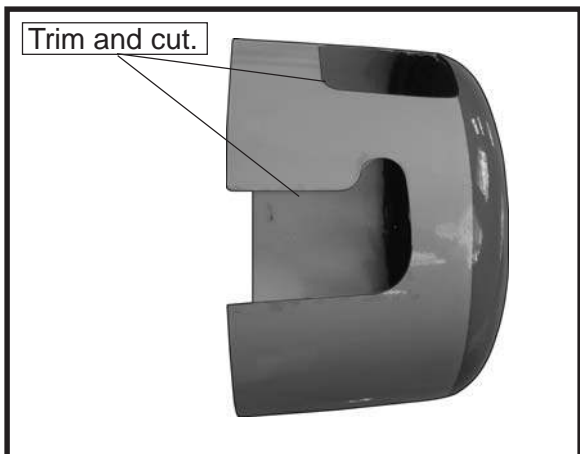
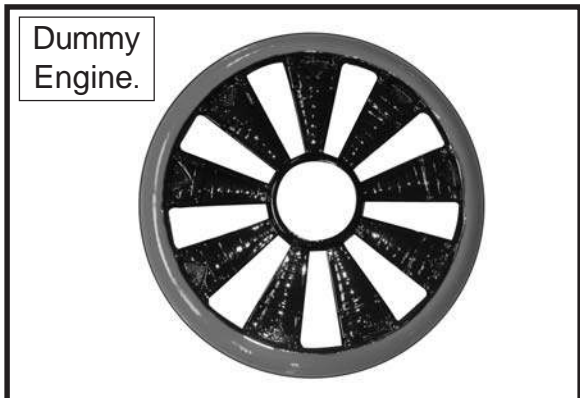

**Electric Conversion (Ep Power) (OPTION).**

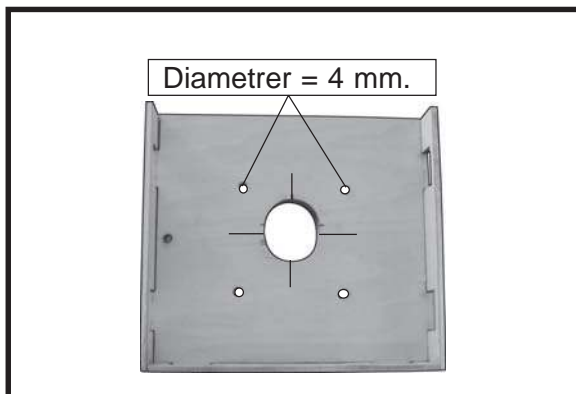
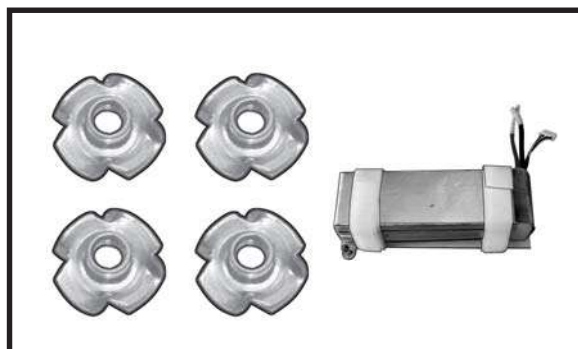

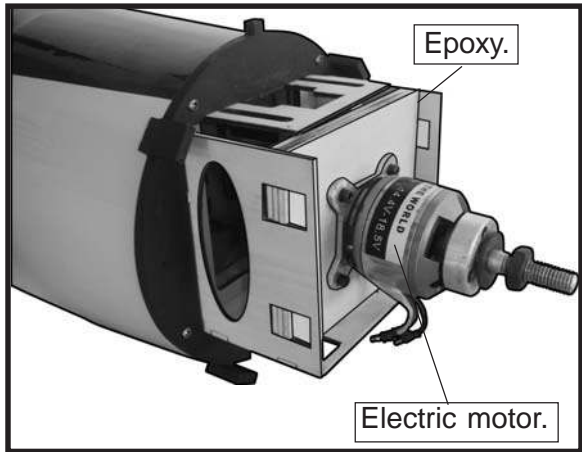
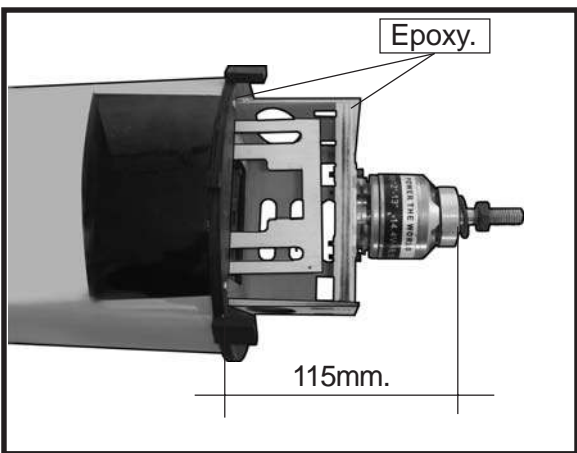
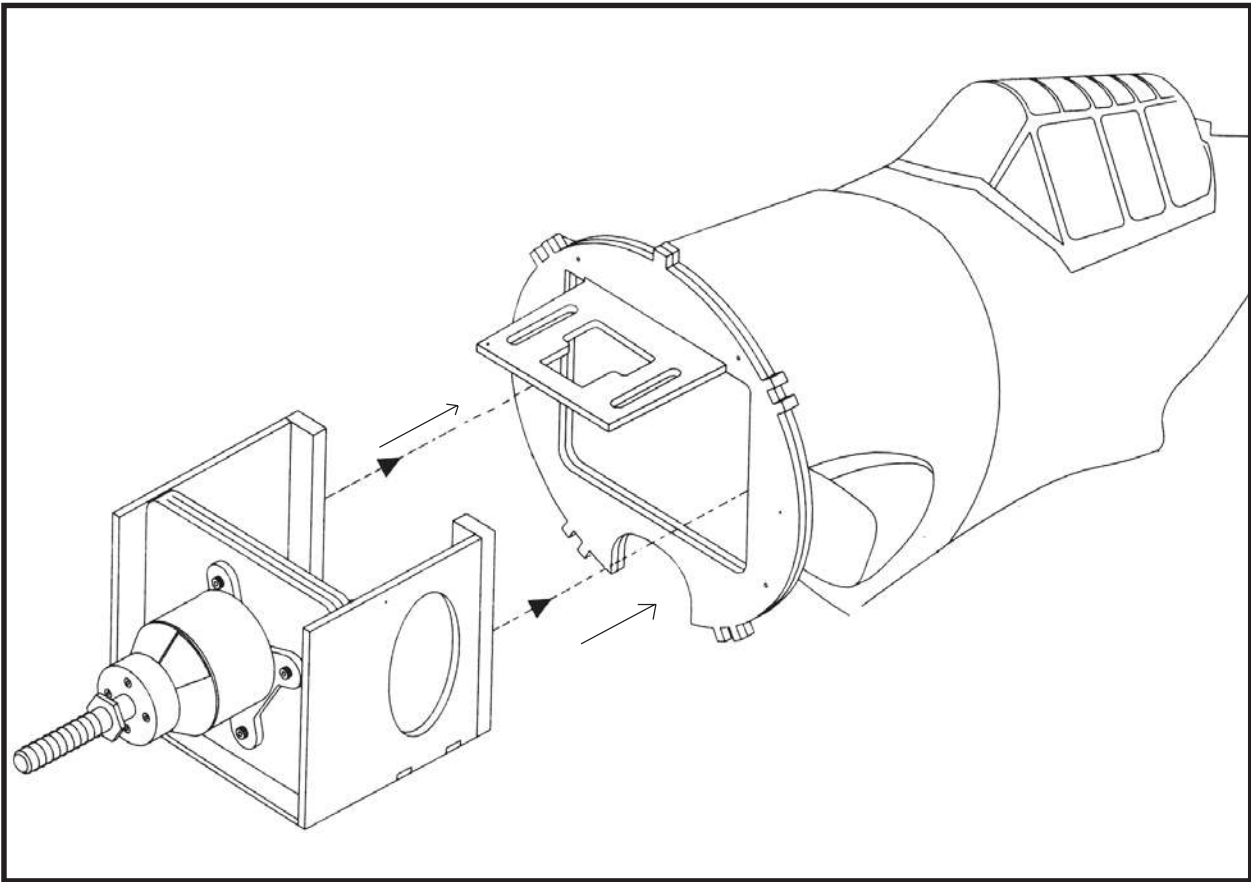
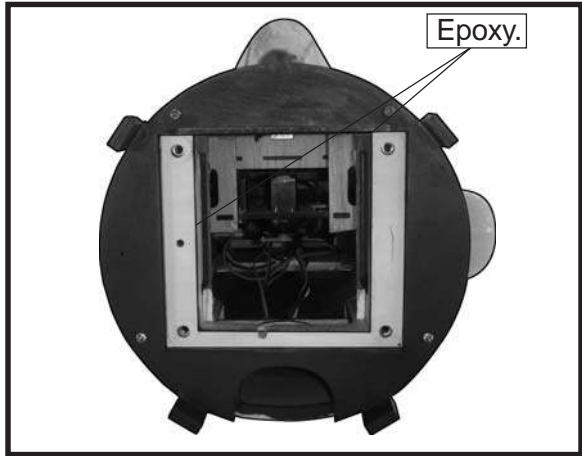
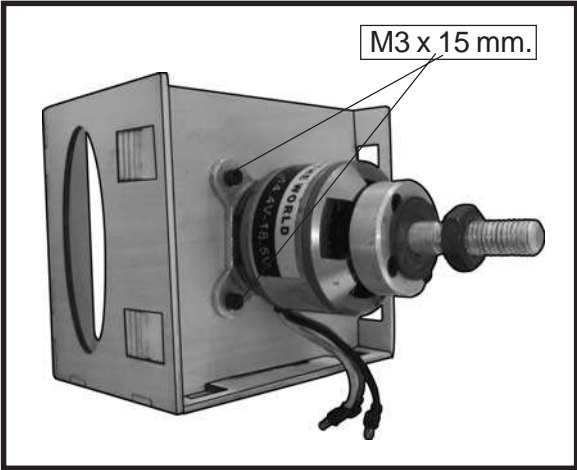

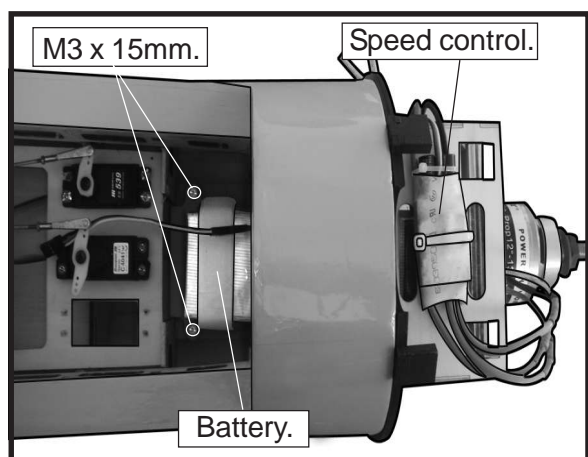
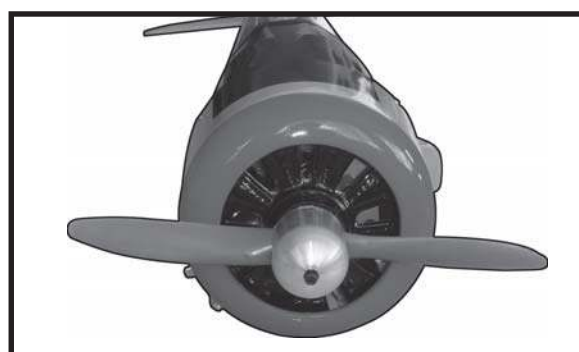
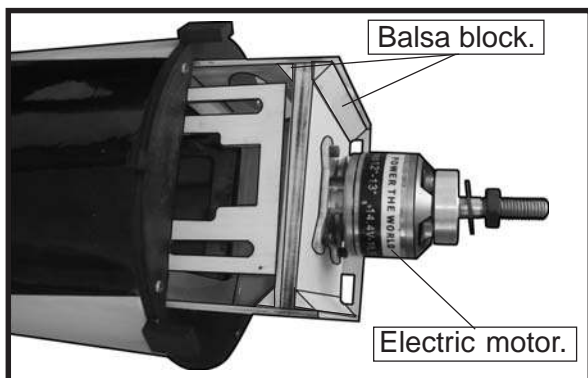
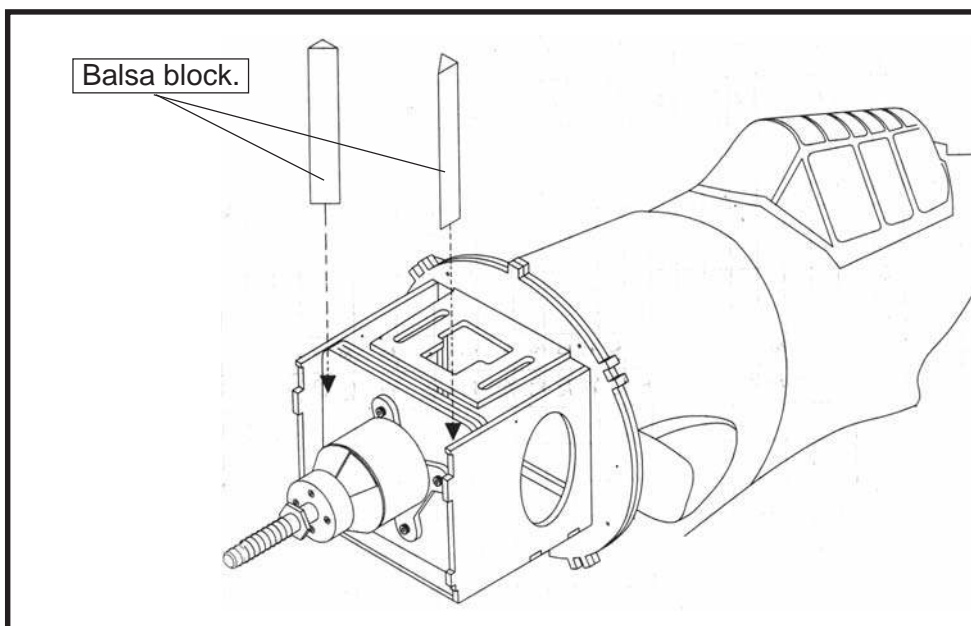

**INSTALLING THE AILERON SERVOS.**

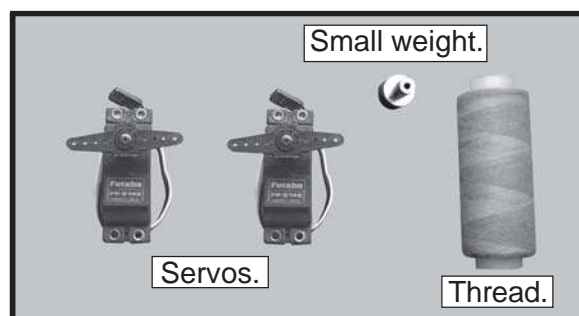

**SPINNER INSTALLATION.**

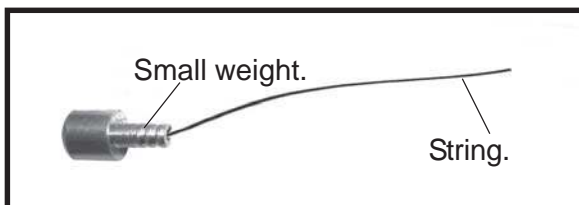



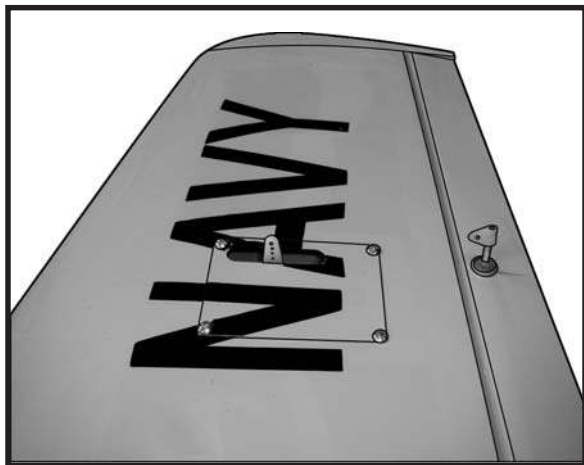
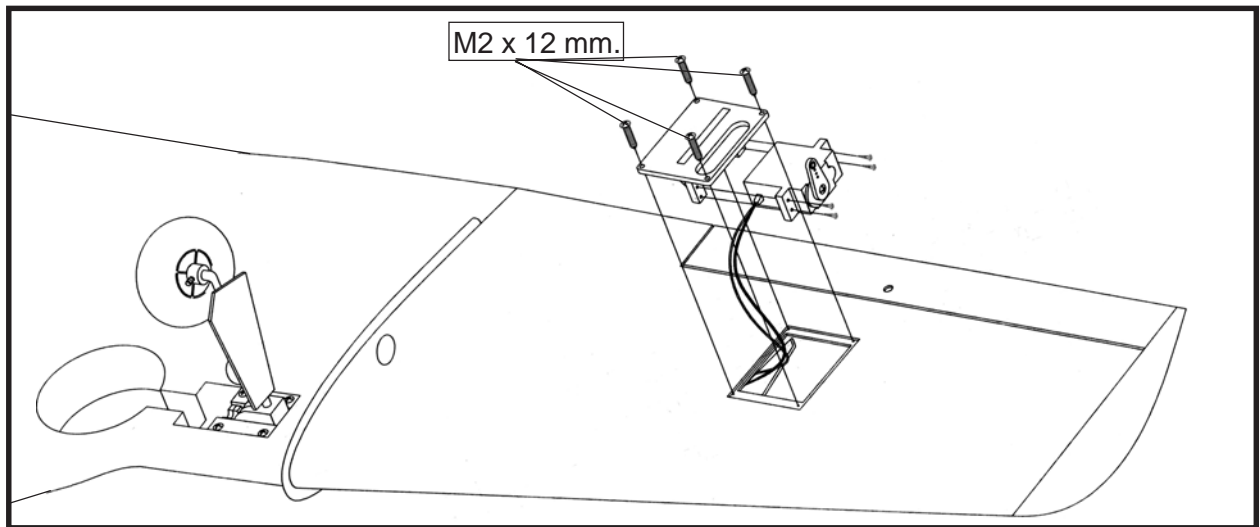
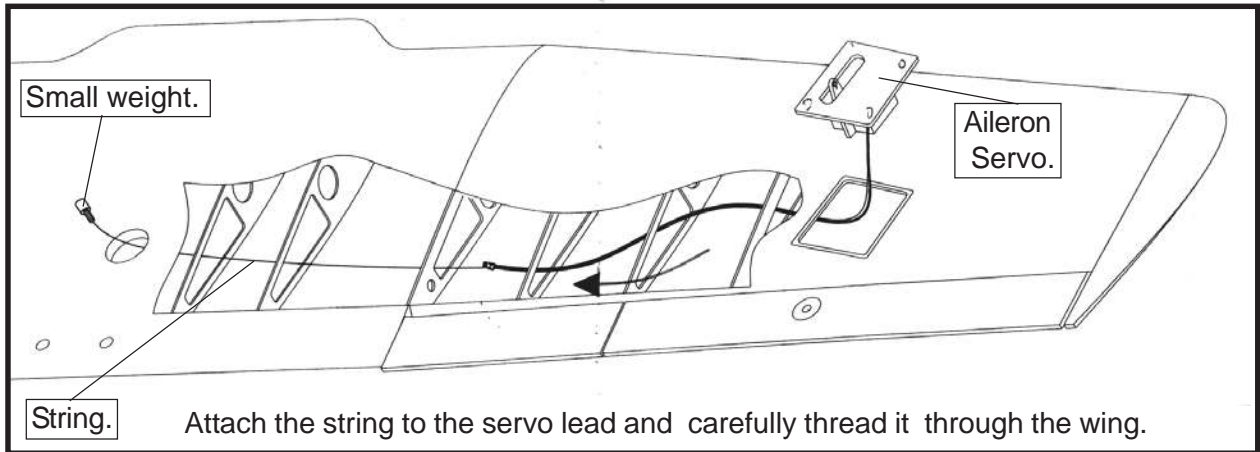

**INSTALLING THE FUSELAGE SERVO-SWITCH.**

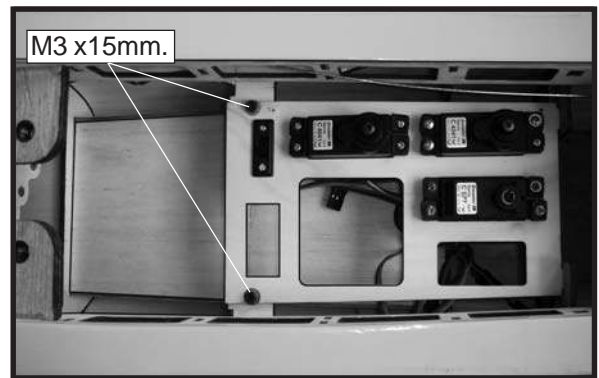

**THROTTLE SERVO ARM INSTALLATION.**

- 1) Install adjustable servo connector in the servo arm as same as picture below:

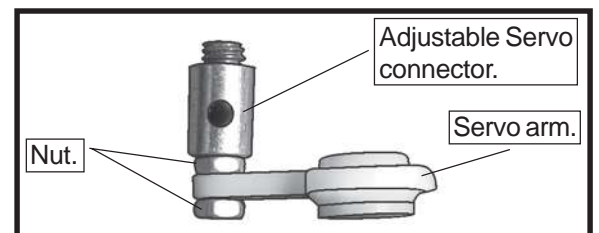
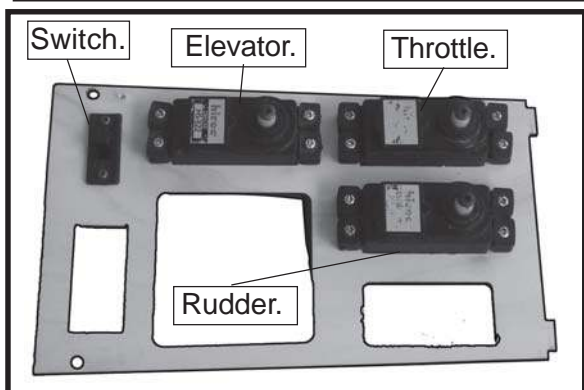

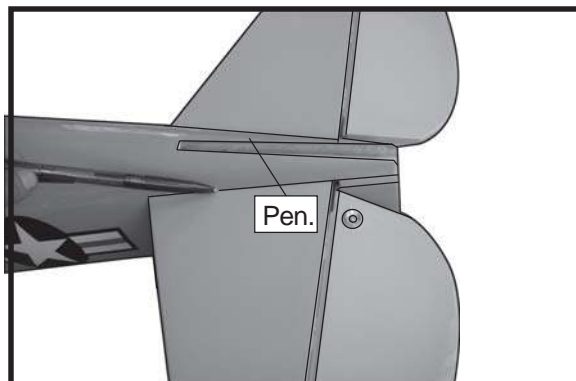
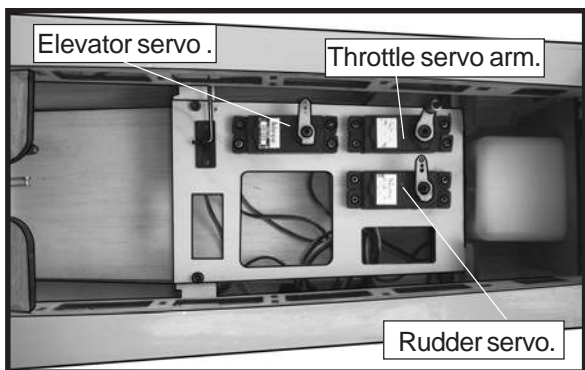

**INSTALLING THE HORIZONTAL STABILIZER.**

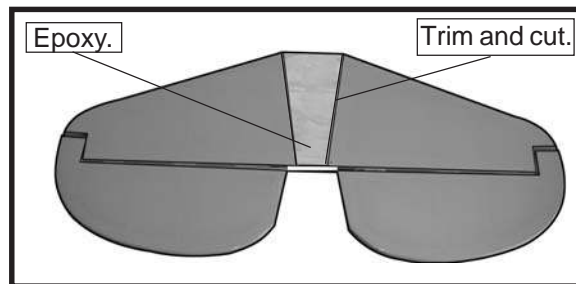
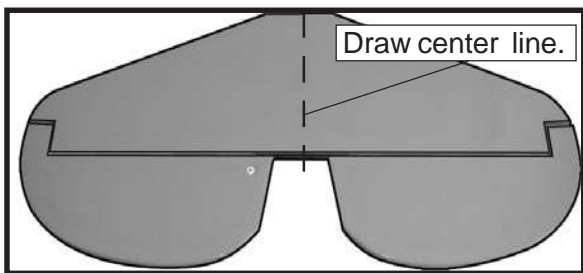

 *When cutting through the covering to remove it, cut with only enough pressure to only cut through the covering itself. Cutting into the balsa structure may weaken it.*

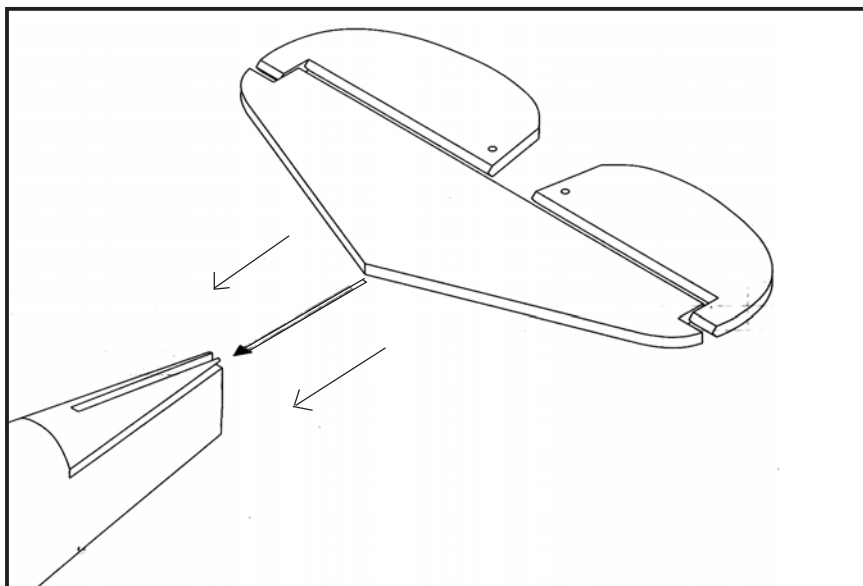
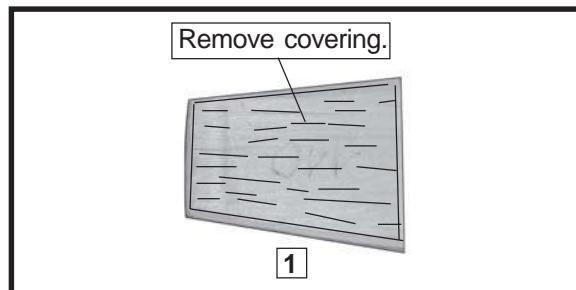
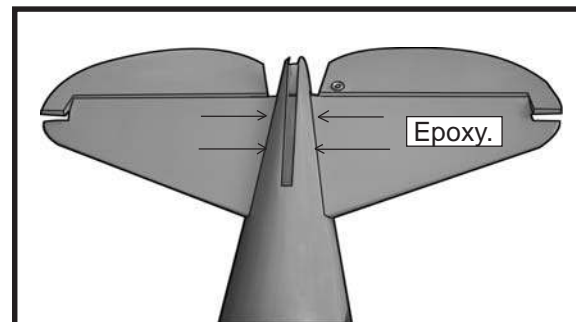

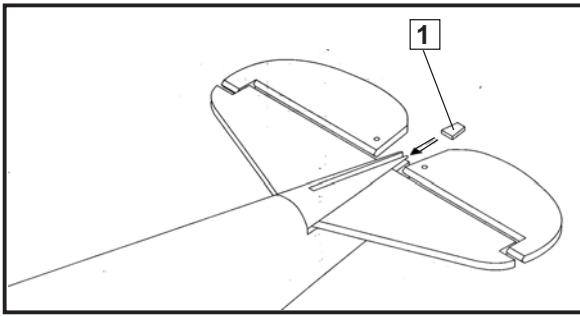

**INSTALLING THE VERTICAL STABILIZER.**

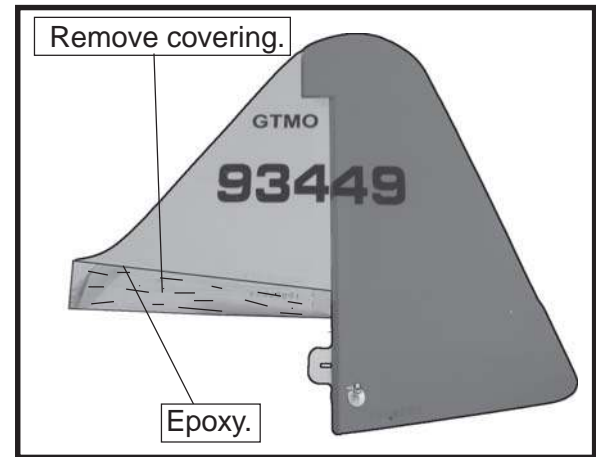
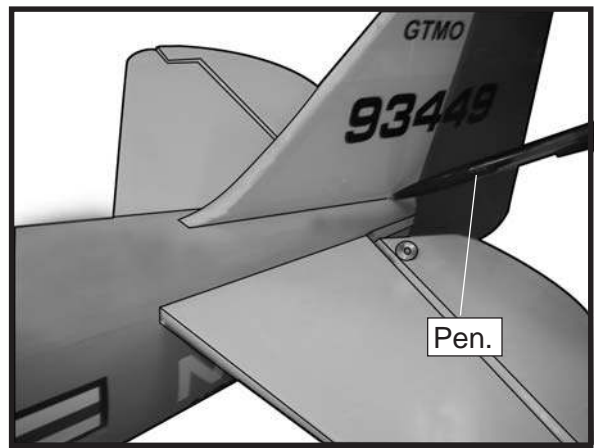
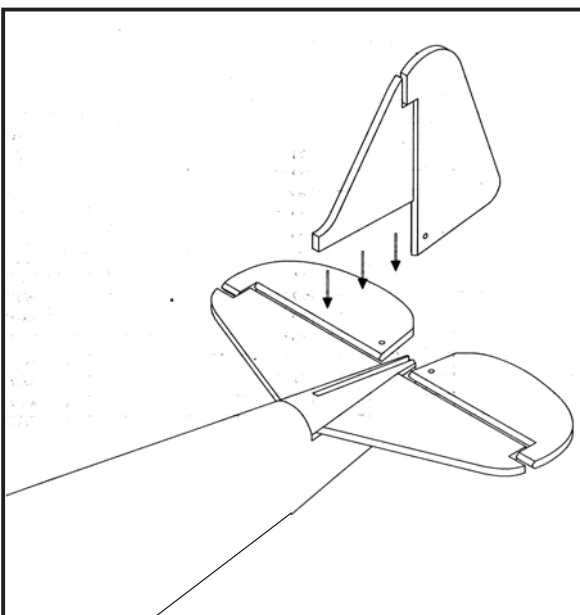
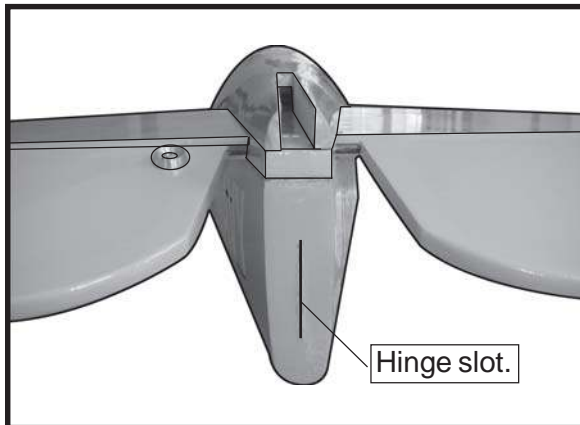

**!** *When cutting through the covering to remove it, cut with only enough pressure to only cut through the covering itself. Cutting into the balsa structure may weaken it.*

Put the vertical stabilizer into the in the top of the horizontal fin. The bottom edge of the stabilizer should also be firmly pushed against the top of the horizontal stabilizer.

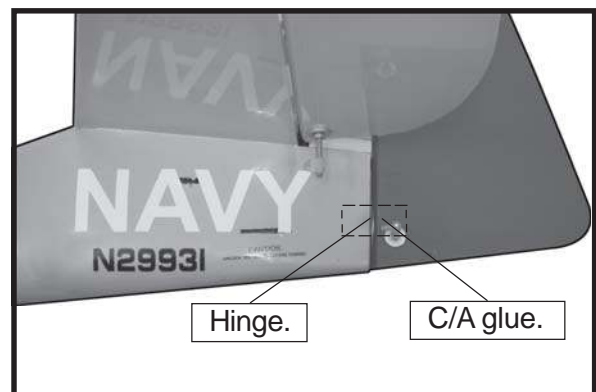
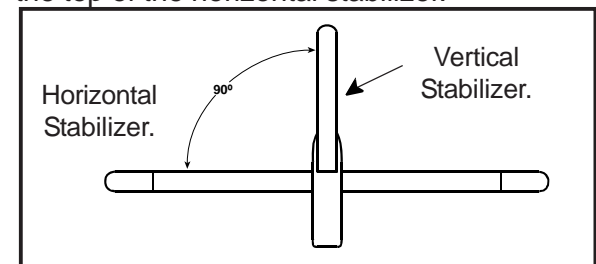

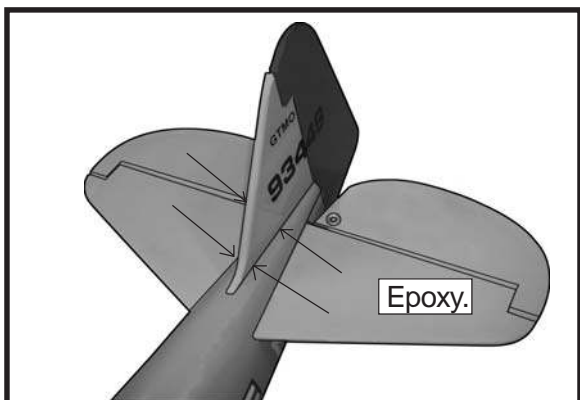

**INSTALLATION THE PUSHROD.**

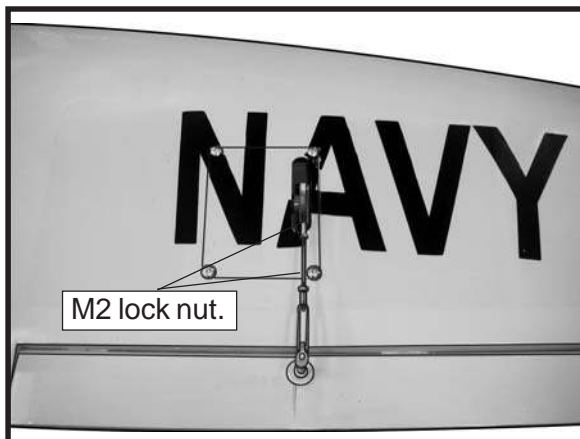
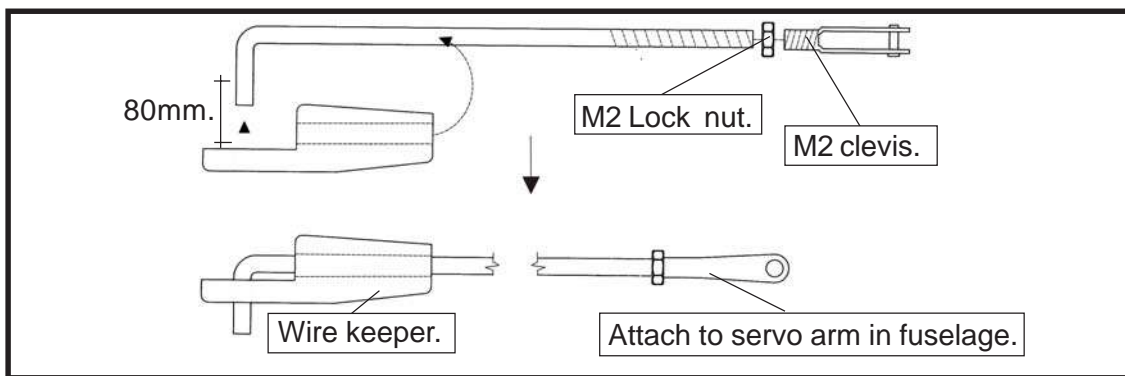
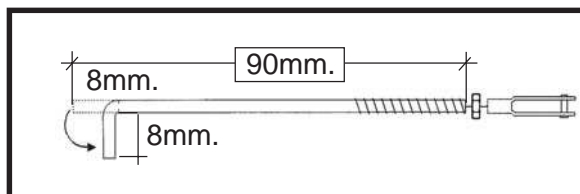
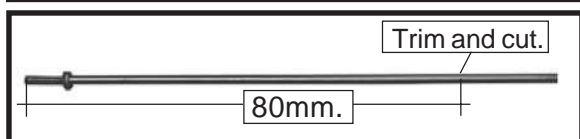

Repeat the procedure for the other wing half.

**ELEVATOR - RUDDER PUSHROD INSTALLATION.**

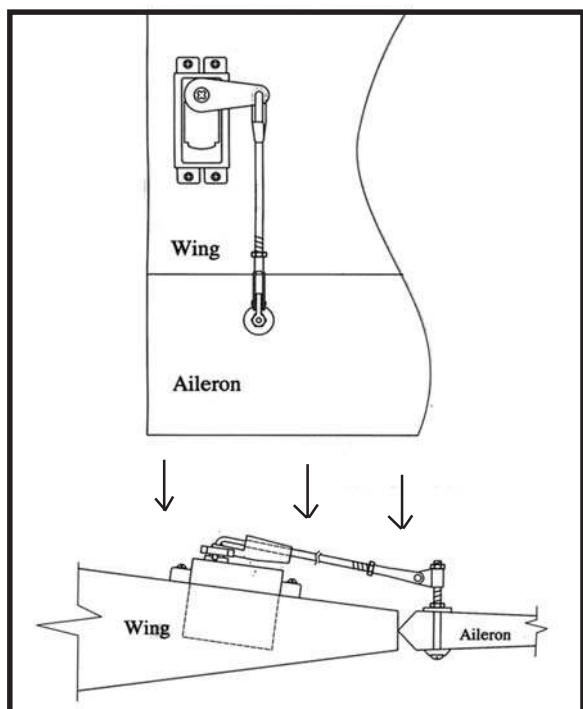

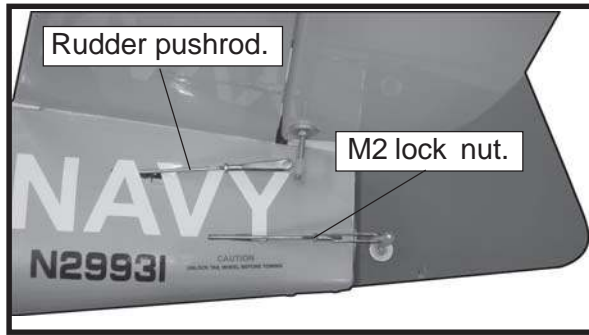

Elevator and rudder pushrods assembly follow pictures below.

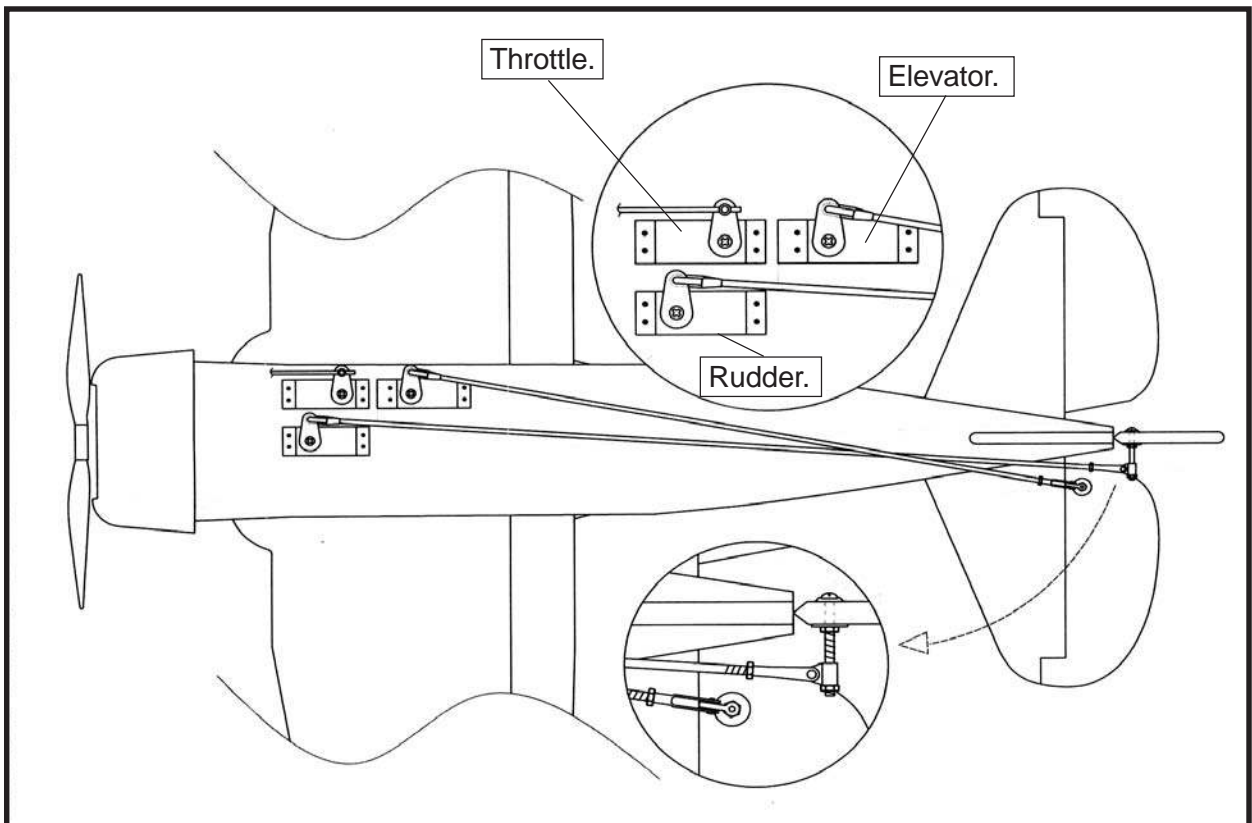
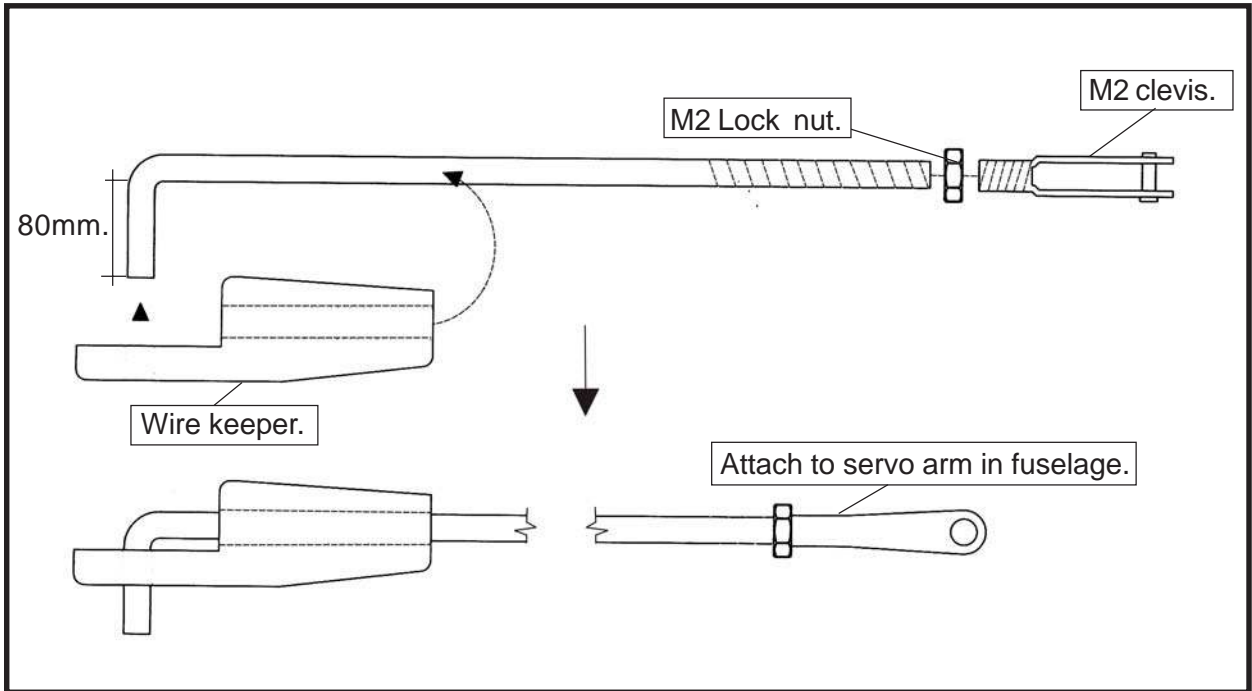

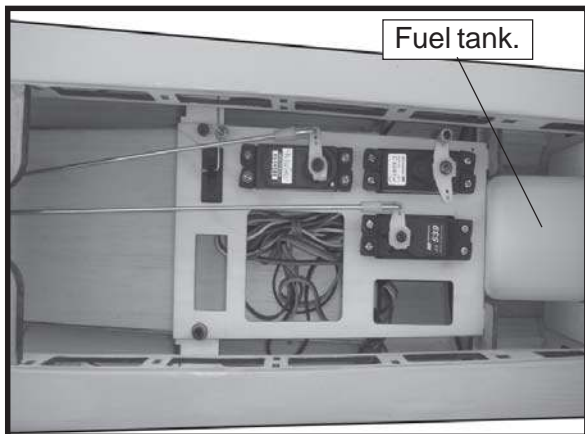

**MOUNTING THE TAIL WHEEL.**

See picture below.

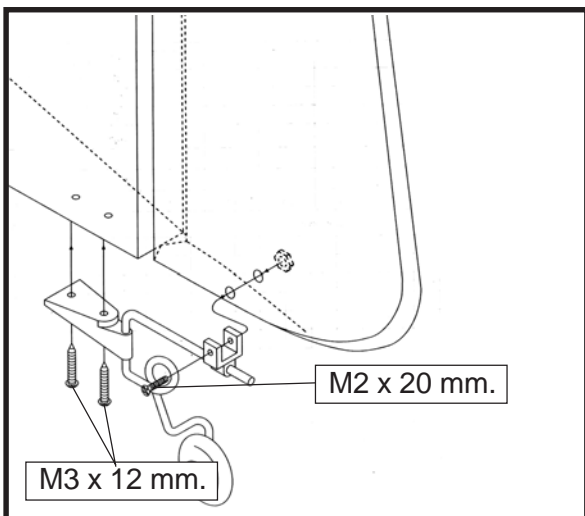

**INSTALLATION PILOT.**

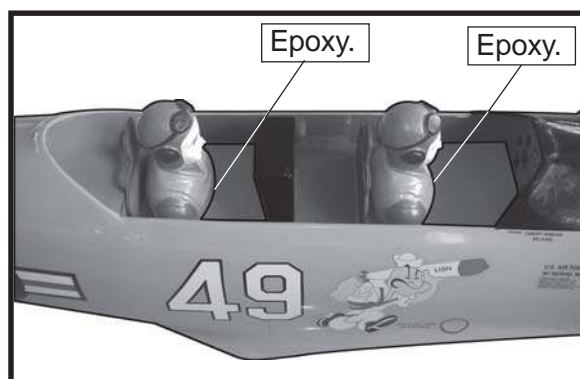
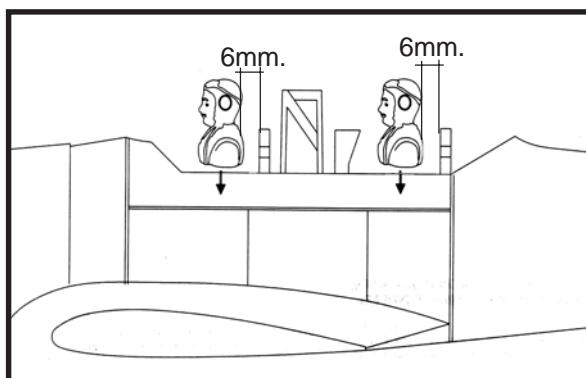
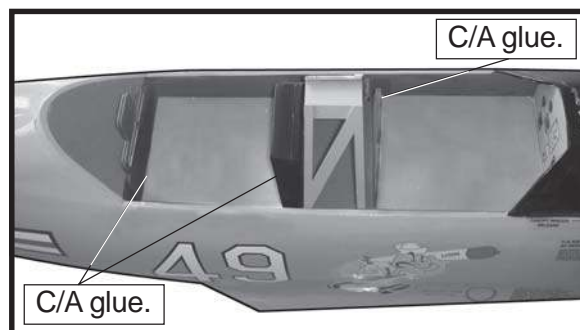
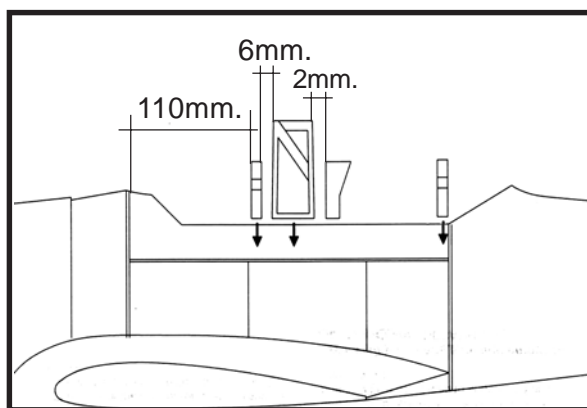
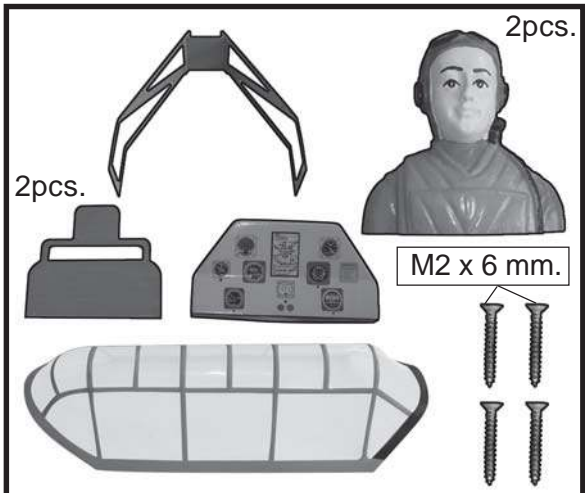

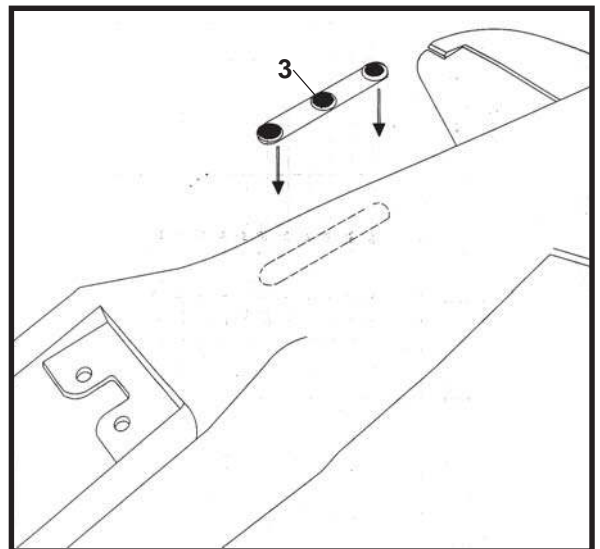
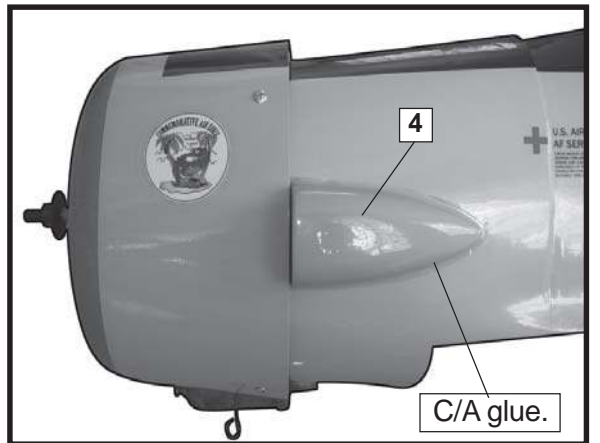
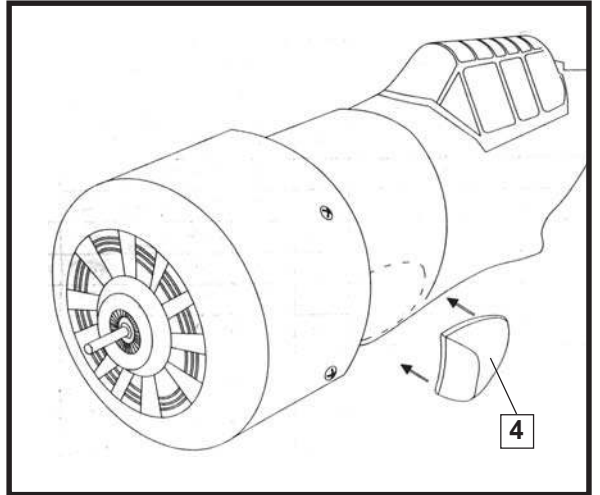
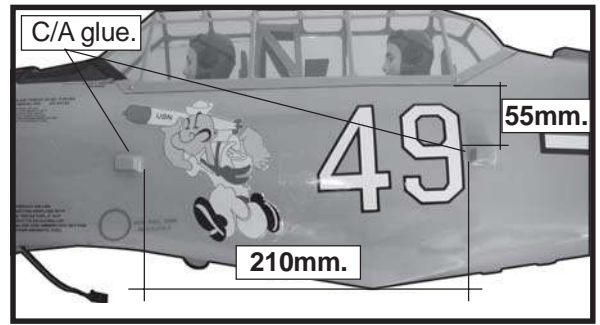
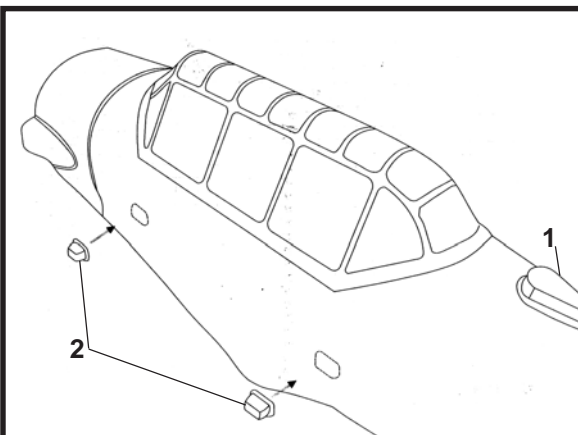
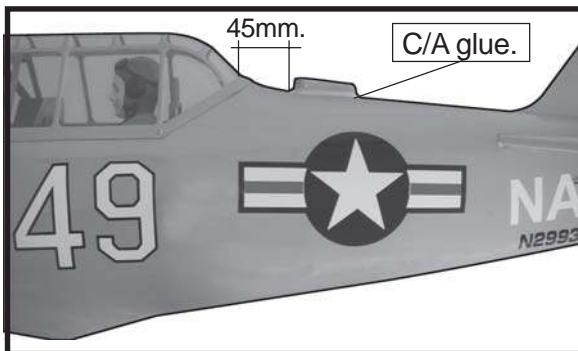
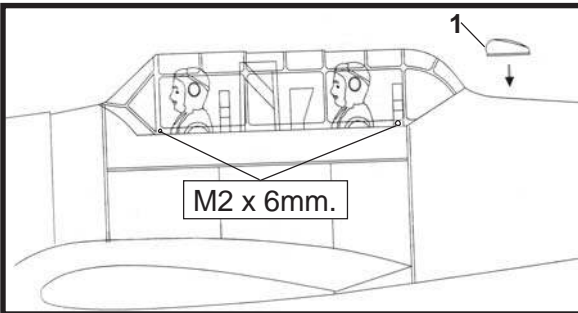
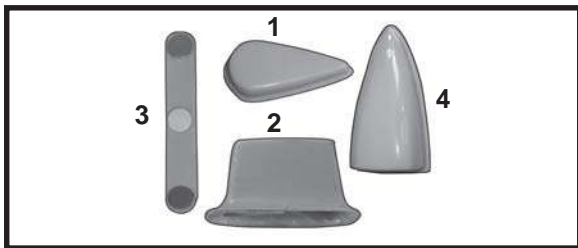
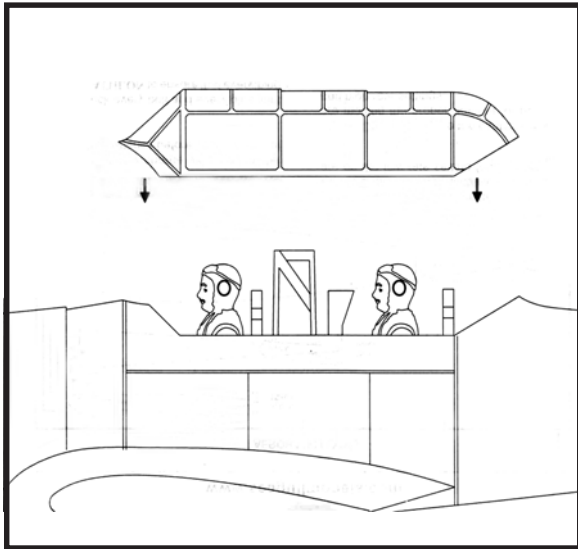

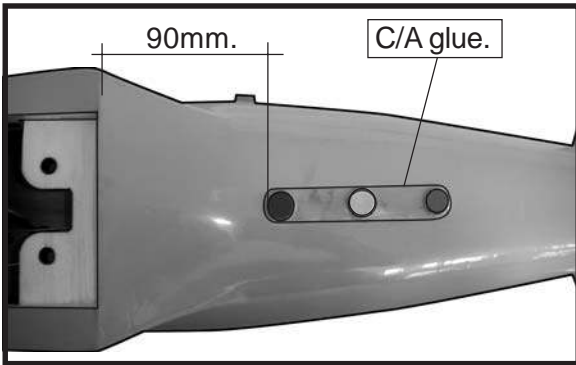

**INSTALLING THE RECEIVER.**

- 1) Plug the six servo leads and the switch lead into the receiver. Plug the battery pack lead into the switch also.
- 2) Wrap the receiver and battery pack in the protective foam rubber to protect them from vibration.
- 3) Route the antenna in the antenna tube inside the fuselage and secure it to the bottom of fuselage using a plastic tape.

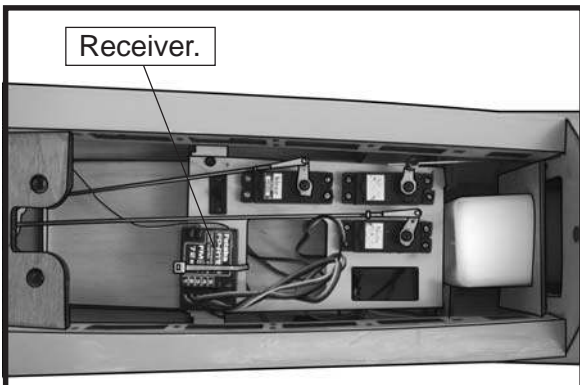

**ATTACHMENT WING-FUSELAGE.**

Bolt the to fuselage. See pictures below.

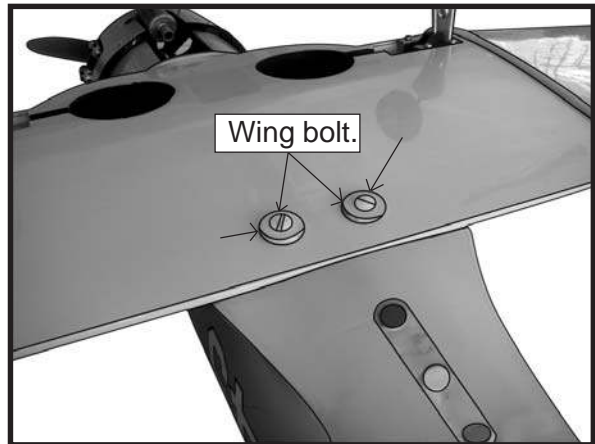

**BALANCING.**

- 1) It is critical that your airplane be balanced correctly. Improper balance will cause your plane to lose control and crash. The center of gravity is located **60mm** back from the leading edge of the wing, See picture below.
- 2) If the nose of the plane falls, the plane is nose heavy. To correct this first move the battery pack further back in the fuselage. If this is not possible or does not correct it, stick small amounts of lead weight on the fuselage sides under the horizontal stabilizer. If the tail of the plane falls, the plane is tail heavy.

To correct this, move the battery and receiver forward or if this is not possible, stick weight onto the firewall or use a brass heavy hub spinner hub. When balanced correctly, the airplane should sit level or slightly nose down when you lift it up with your fingers.

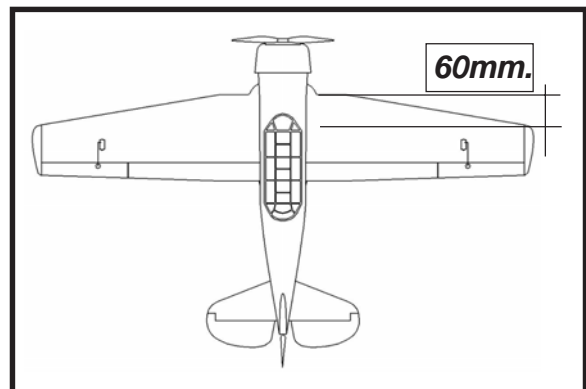



## CONTROL THROWS

### Ailerons:

High Rate :

Up : 12mm

Down : 12mm

Low Rate :

Up : 10mm

Down : 10mm

### Rudder:

High Rate :

Right : 20mm

Left : 20mm

Low Rate :

Right : 15mm

Left : 15mm

### Elevator:

High Rate :

Up : 12mm

Down : 12mm

Low Rate :

Up : 10mm

Down : 10mm

\* Hopefully you fun for installing parts.

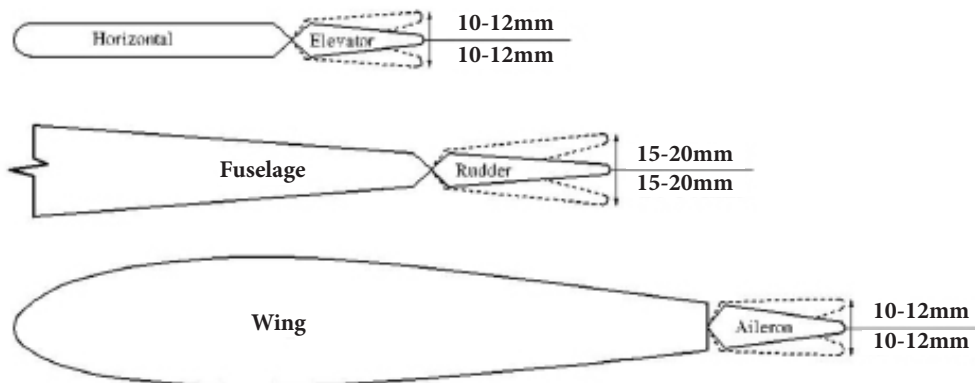

**FLIGHT PREPARATION**

Check the operation and direction of the elevator, rudder, ailerons and throttle.

A) Plug in your radio system per the manufacturer's instructions and turn everything on.

B) Check the elevator first. Pull back on the elevator stick. The elevator halves should move up. If they do not, flip the servo reversing switch on your transmitter to change the direction.

C) Check the rudder. Looking from behind the airplane, move the rudder stick to the right. The rudder should move to the right. If it does not, flip the servo reversing switch on your transmitter to change the direction.

D) Check the throttle. Moving the throttle stick forward should open the carburetor barrel. If it does not, flip the servo reversing switch on your transmitter to change the direction.

E) From behind the airplane, look at the aileron on the right wing half. Move the aileron stick to the right. The right aileron should move up and the other aileron should move down. If it does not, flip the servo reversing switch on your transmitter to change the direction.

**PREFLIGHT CHECK**

1) Completely charge your transmitter and receiver batteries before your first day of flying.

2) Check every bolt and every glue joint in the **Master Scale kit Edition AT-6 Texan 63" 10-15cc** to ensure that everything is tight and well bonded.

3) Double check the balance of the airplane. Do this with the fuel tank empty.

4) Check the control surfaces. All should move in the correct direction and not bind in any way.

5) If your radio transmitter is equipped with dual rate switches double check that they are on the low rate setting for your first few flights.

6) Check to ensure the control surfaces are moving the proper amount for both low and high rate settings.

7) Check the receiver antenna. It should be fully extended and not coiled up inside the fuselage.

8) Properly balance the propeller. An out of balance propeller will cause excessive vibration which could lead to engine and/or airframe failure.

*We wish you many safe and enjoyable flights  
with your **Master Scale kit Edition AT-6 Texan 63" 10-15cc.***

---

*If you have any queries, or are interested in our products,  
please feel free to contact us*

**Factory :** 12/101A - Hamlet 4 - Le Van Khuong Street - Dong Thanh Ward -  
Hoc Mon District - Ho Chi Minh City - Viet Nam.

**Office :** 62/8 Ngo Tat To Street - Ward 19 - Binh Thanh District - Ho Chi Minh  
City - Viet Nam

**Phone :** 848 - 86622289 or 848- 36018777

**Website :** [www.SeagullModels.com](http://www.SeagullModels.com)

**Email :** [Sales@seagullmodels.com](mailto:Sales@seagullmodels.com)

**Facebook :** [www.facebook.com/SeaGullModels](http://www.facebook.com/SeaGullModels).